



# Oplemenjavanje užih strana ploča

# Vrste lepkoiva

- Termoplastični – topljivi
- Disperzioni
- Kondenzacioni
- Kontaktni
- EVA
- PVA-c
- KF
- PUR

# Postupci oplemenjavanja

- HH
- VH
- VHR
- HV
- HA

## MATERIJLA ZA OPLEMENJAVANJE

- Furnir
- Folija
- Laminat
- Masiv

# Hladno hladni postupak

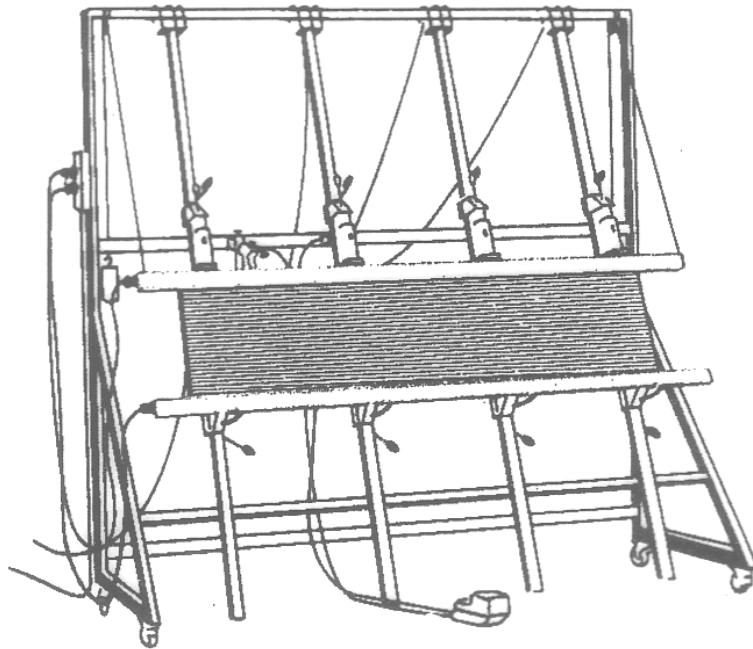

# Vruće hladni postupak

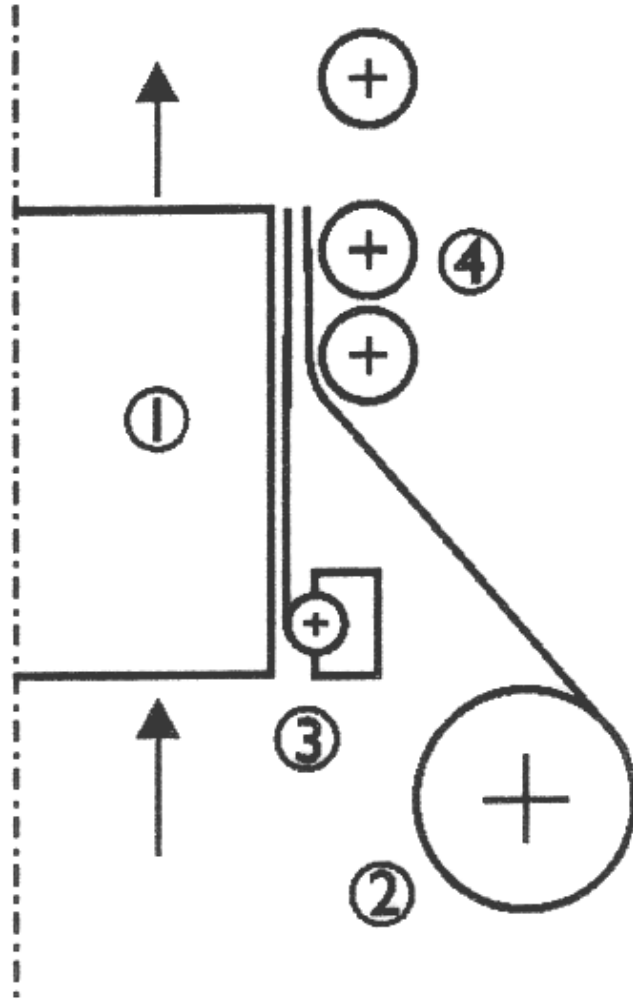

# Vruće hladni reaktivni postupak

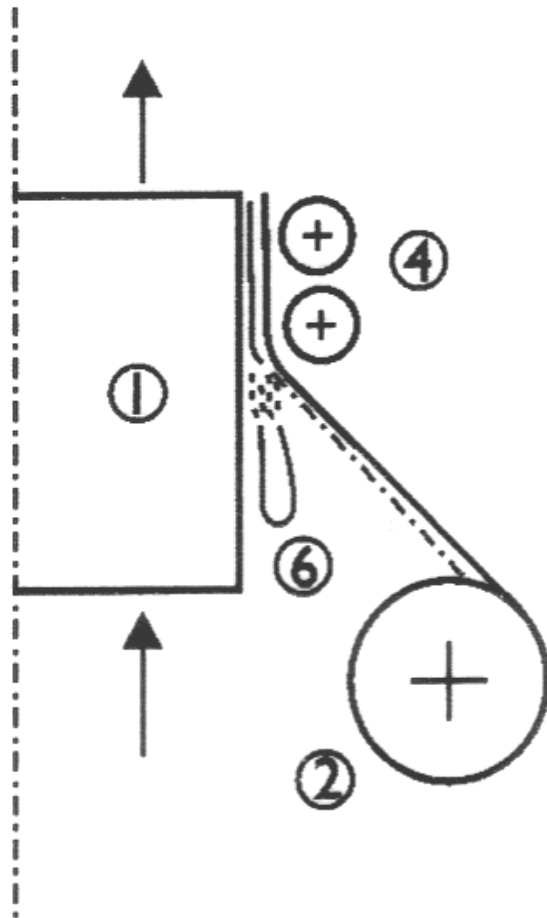

# Hladno vrući postupak

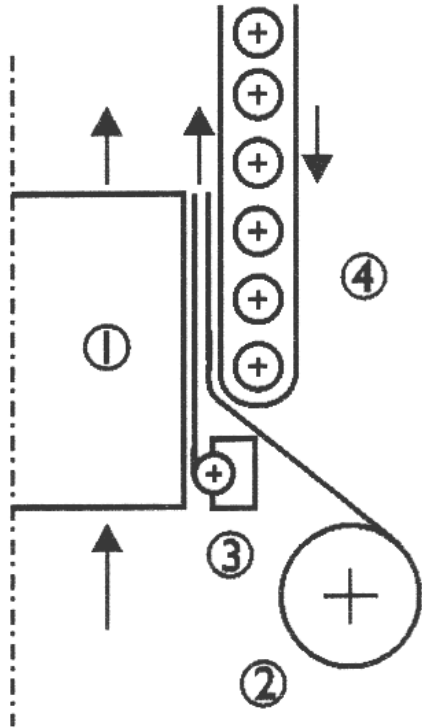

# Hladno aktivirajući postupak

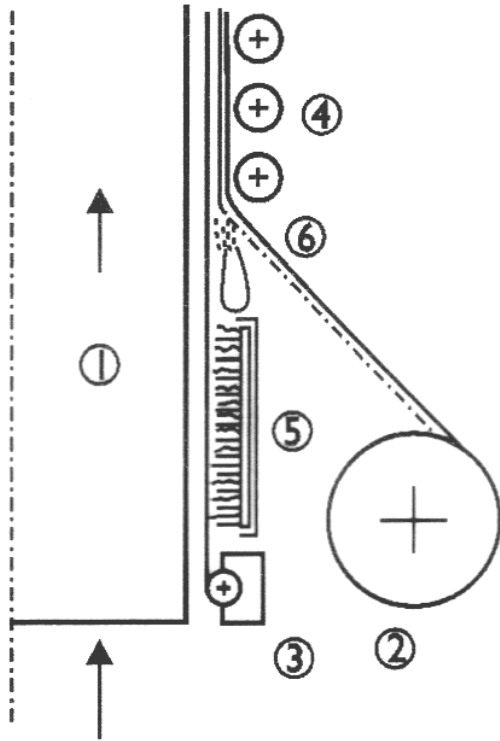



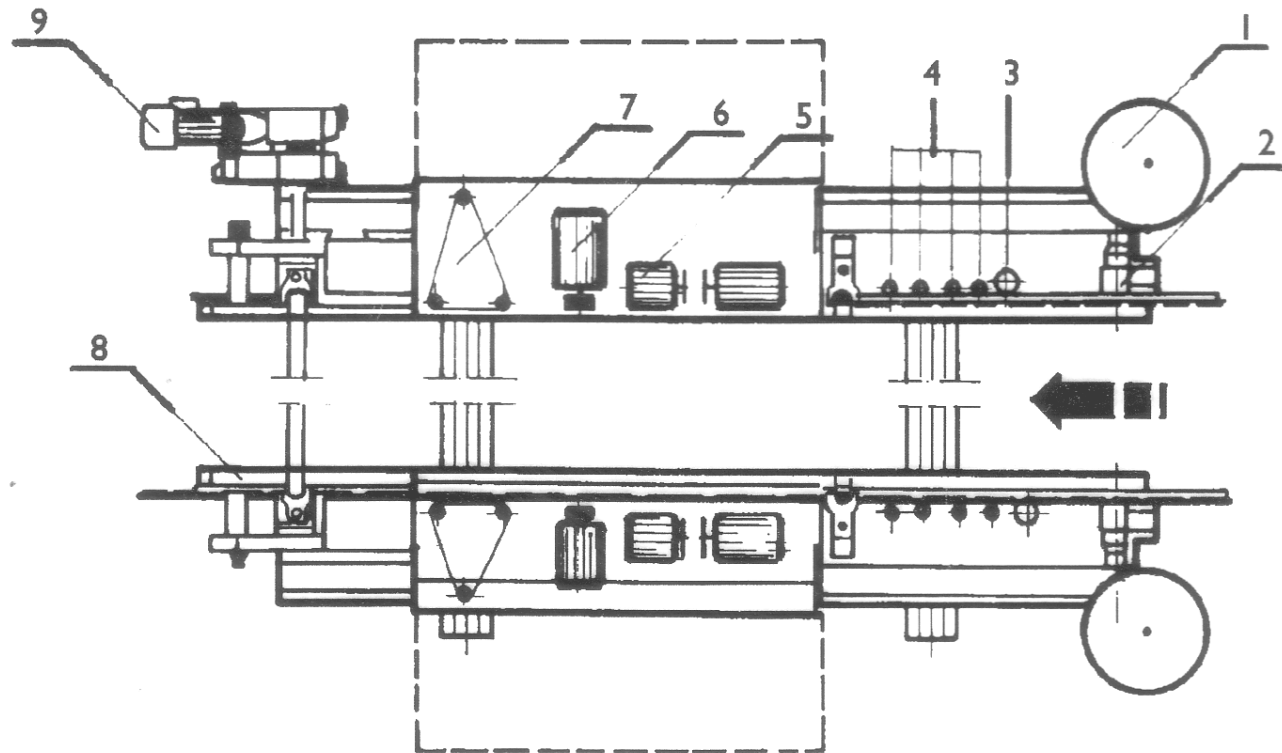

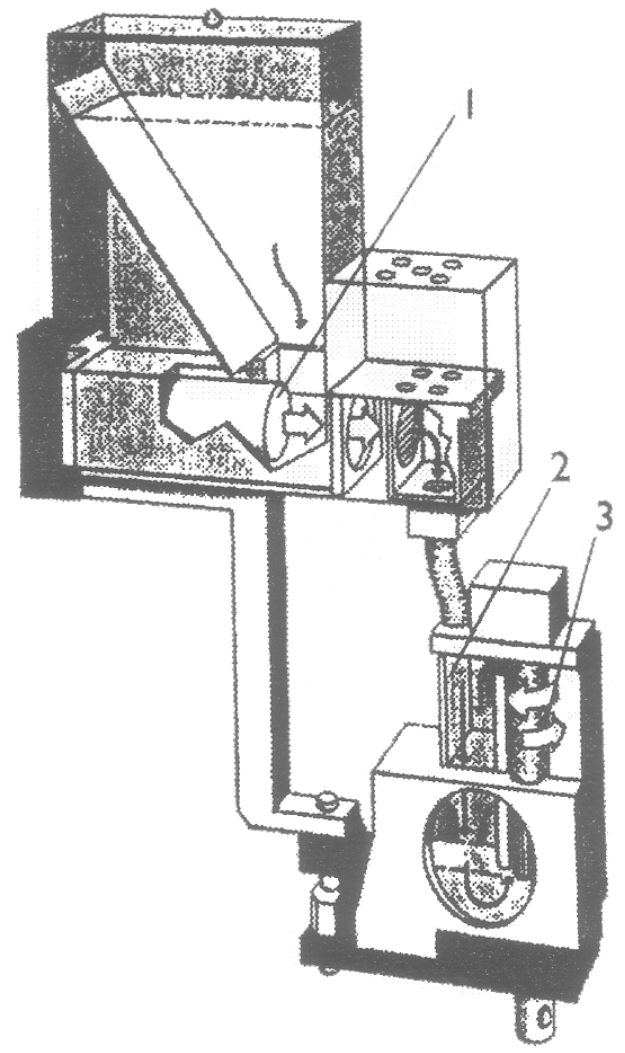
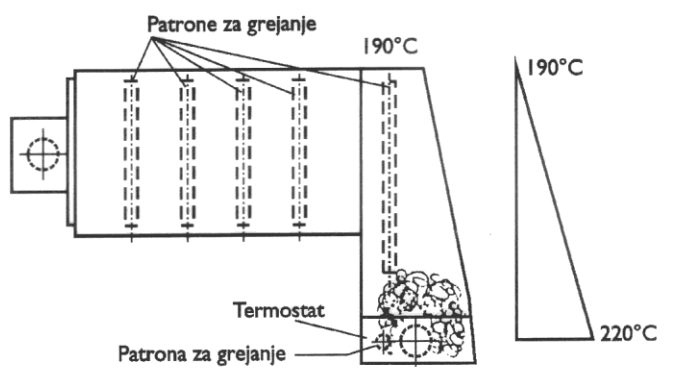
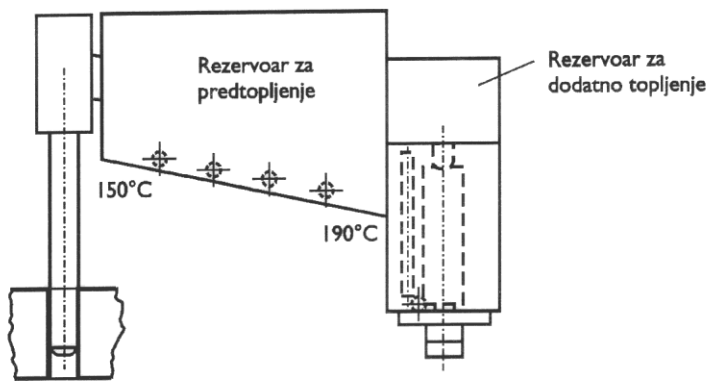
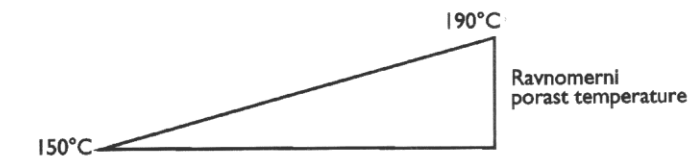

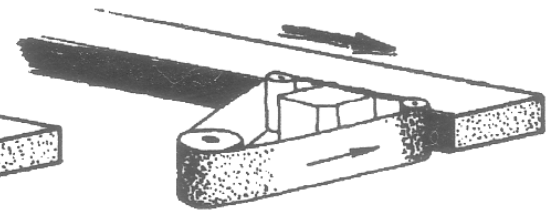
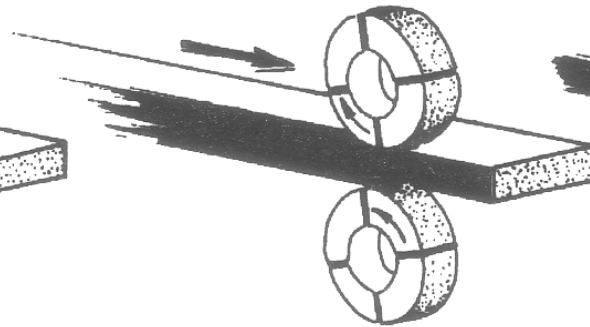
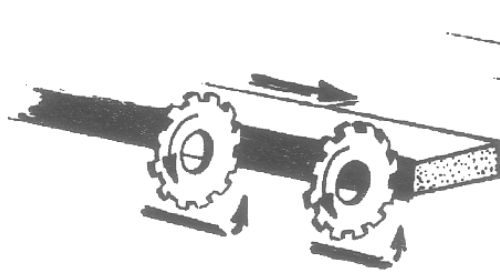
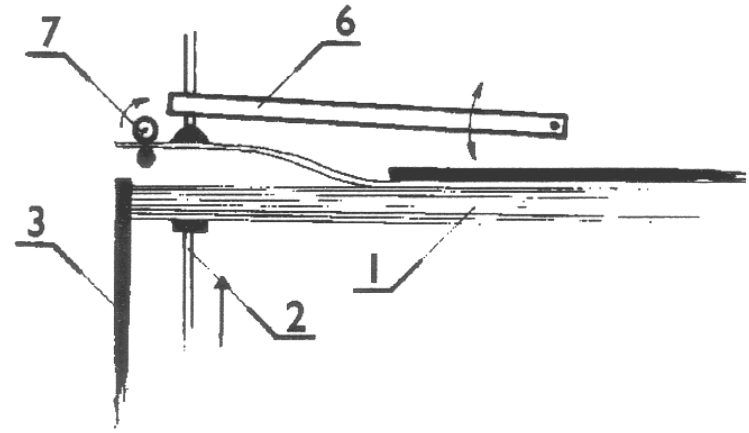
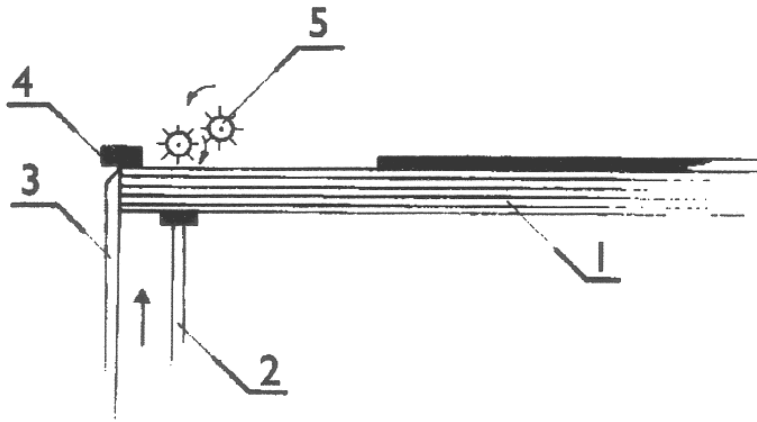

# Oplemenjavanje profilisanih robova ploča sa pravolinijskim konturama - Softforming

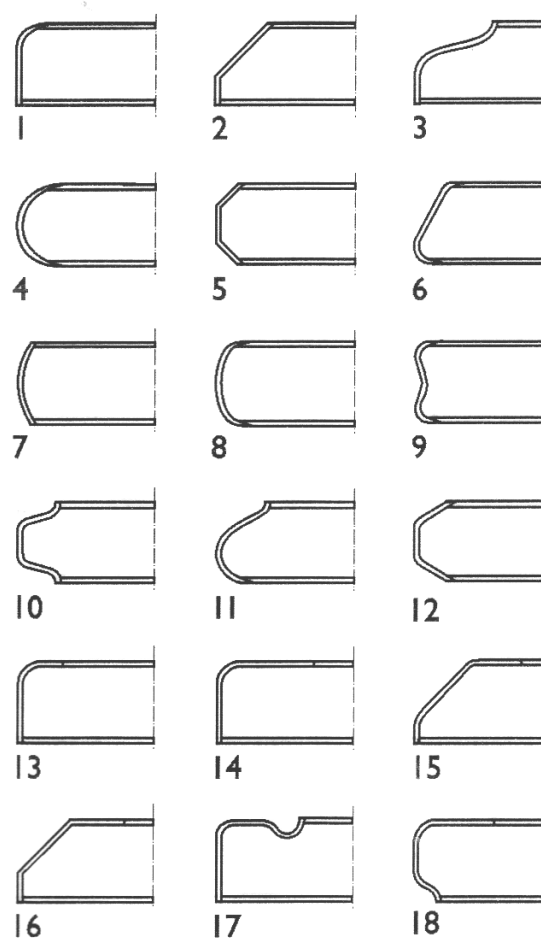
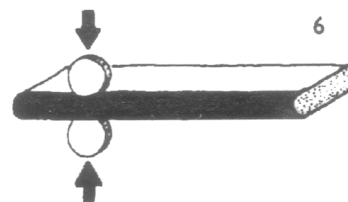
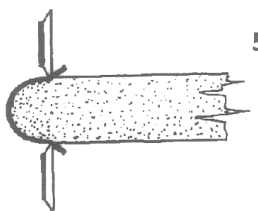
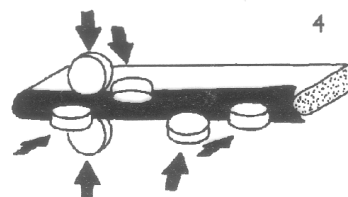
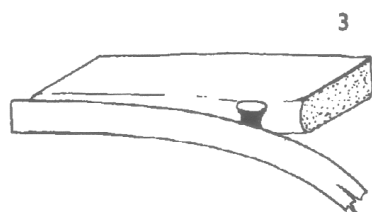
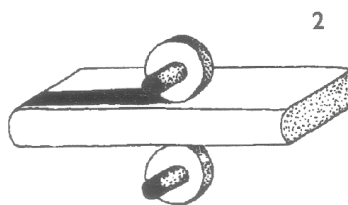
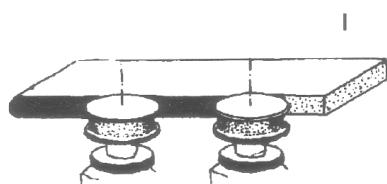

# Oblaganje ploča laminatima

*oblaganje širih strana*

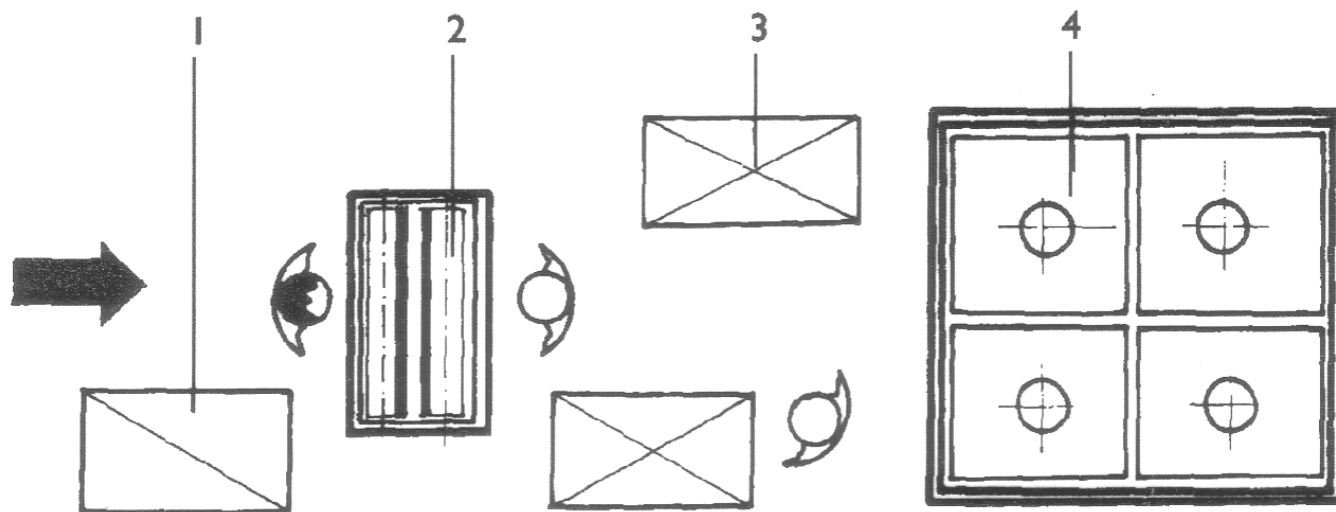

# Oblaganje uskih profilisanih površina- Postforming

