

leitz

User encyclopedia

Leitz Lexicon Edition 7



11. User encyclopedia

11.1 Materials science	11.1.1 Wood as a raw material and basic material	2
	11.1.2 Wood materials	6
	11.1.3 Plastics	9
	11.1.4 Mineral materials	11
	11.1.5 Non-ferrous metals	12
	11.1.6 Composite materials	13
11.2 Cutting materials		14
11.3 Fundamental cutting principles	11.3.1 Essential geometry elements in a cutting tool	19
	11.3.2 Cutting directions and procedures when cutting wood	20
	11.3.3 Cutting kinematics	21
	11.3.4 Processing quality	22
	11.3.5 Tool parameters	25
11.4 Machine tools	11.4.1 Tool types	28
	11.4.2 Types of tools	31
	11.4.3 Tool clamping systems	40
	11.4.4 Tool maintenance	43
	11.4.5 Safety	51
	11.4.6 Low noise tools	53
	11.4.7 Chip and dust extraction	54
	11.4.8 Tools as intelligent process components	56
11.5 Wood processing machines	11.5.1 Through feed machines	58
	11.5.2 Stand alone machines	59
	11.5.3 Machines for manual feed	61
	11.5.4 Hand operated electrical tools	62



Tree

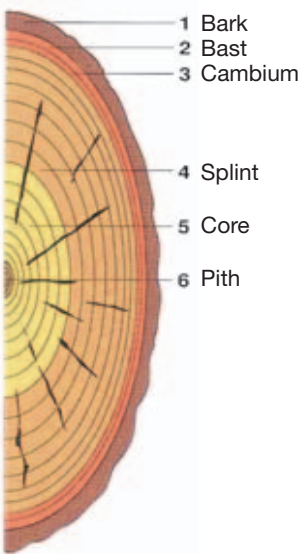

Structure of a trunk

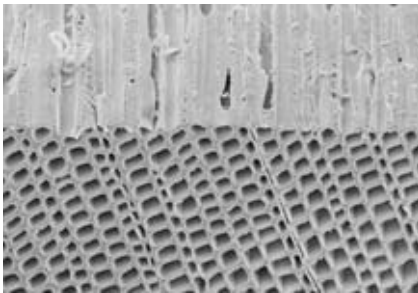

Cross section of softwood (spruce)

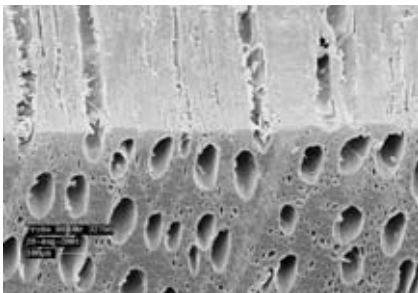

Cross section of hardwood (beech)

As a renewable material, wood is a raw material which is important because of its strength and low density and because it is found all over the world. As a result, wood is used widely in support structures in timber construction and in non load-bearing areas such as building components, furniture or interior fittings. In its dry state, wood possesses low thermal conductivity properties due to its porous cell structure which means it has a certain level of heat insulation. Wood is therefore a good raw material from an energy point of view and is, for this reason, used in window frame elements or insulation panels. Wood is also used in its natural form (solid wood) or converted into wood materials.

There are several specific properties which must be considered in the selection, application and processing of solid wood. The **most important properties** are: **inhomogeneity, anisotropicity, porosity, hygroscopicity and biodegradability**. The structure of wood consists of fibres stronger in a longitudinal than in a lateral direction. The fibres consist of cell walls which form the actual wood substance and of vessels (also known as „pores“). The relationship between the volume of the pores and the mass of the wood substance determines the bulk density and varies from one wood type to the next. Depending on the time of year, the pores become larger (spring, summer → **earlywood**, lower density) or smaller (autumn, winter → **latewood**, higher density). This phenomenon can be seen by taking a cross section of the wood and observing the growth rings from successive earlywood and latewood periods. With slow growing wood in cold regions, these growth rings are tight together, whereas with quick growing wood from warmer regions, the growth rings are spread out. In contrast, these differences are barely noticeable in tropical woods.

Wood develops by a process of cell growth and cell multiplication within the growth ring, or cambium. Most cells develop inwards to form the wood structure, while some grow outward, forming the bark and phloem, or inner bark. Every tree is built in layers; a cross-section through the trunk is as follows from outside to inside: bark, phloem, cambium, sapwood (medullary rays, annual rings, spring growth and summer growth, resin ducts), heartwood (without sap capillaries: this is purely structural in function) and pith.

There are two main wood types: **hardwoods and coniferous woods**. Coniferous woods are older in evolutionary terms and therefore have less complex cell structures involving two cell types. The tracheids (elongated, tapered) are strong and act as conductors. Water is exchanged between the cells through so called pits or bordered pits. The parenchyma cells (rectangular) are responsible for transporting the nutrients and storing starch and fats.

In contrast, functions are divided between the cells in hardwoods. The cells are divided into vascular tissue, ground tissue and seed tissue. The main feature which differentiates hardwoods from coniferous woods is the vessel elements (tracheids) in the vascular tissue. These can be seen as pores in a cross sectional view, and as striations in a longitudinal view. The arrangement of these wood vessels determines whether the wood is ring porous (e.g. oak, ash), semi ring porous (e.g. cherry, walnut) or diffuse porous (e.g. birch, beech, poplar).

While there is a general similarity between softwood and conifer, hardwood and broadleaf, there are exceptions such as yew – which is a hardwood – and alder, birch, lime, poplar and willow – which are softwoods.

For processing and tool selection, factors such as density, strength, elasticity and hardness are important considerations. Accordingly, the categorisation of **hardwood and softwood** is important insofar as it provides a broad guide to these properties.



Sapwood (bright) and heartwood (dark)
(example pine)

Merely the „appearance“ of the timber, lumber or planed timber can give information on the properties and on the potential level of difficulty during the woodworking process. **Sapwood and heartwood** from a tree have different properties, for example. The sap flows in the outer layers of the trunk. This leads to an outer area of sapwood with a higher level of moisture and inner areas of less moist heartwood. Sapwood and heartwood are always of varying quality. With increasing trunk diameter, the relative size of the heartwood becomes greater as the sapwood or ripewood progressively converts to heartwood. Once converted to heartwood, the material ceases further structural change. Both sapwood and heartwood are present in all types of tree, although they are more easily distinguished in the so called „heartwood trees“ – such as oak, larch, pine, cherry and ash – than in „sapwood trees“ – such as beech, fir and spruce; these may very little in colour.

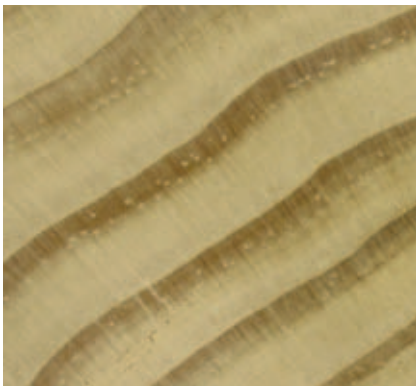

Earlywood (bright) and latewood (dark)
(example Pinus Radiata)

During wood processing and woodworking procedures it must be remembered that wood is a material with varying structures and properties. The growth rings are particularly indicative of this fact in coniferous woods. There are significant differences in hardness between the marked areas of **earlywood and latewood**. During the woodworking process, these circumstances must be taken into consideration and cutting materials, cutting material geometries and process parameters must be adapted correspondingly. When processing various types of wood often a compromise for various types of wood is required.

Bulk density is the decisive factor for most technical properties. Bulk density is the ratio of the mass and volume (including all vessels). Depending on the type of wood, bulk density is usually between 100 kg/m³ and 1200 kg/m³. Higher bulk density means that the wood is harder, firmer, tougher to process and treat and also harder to dry. Tool wear also increases in direct proportion to the bulk density of the wood. Other factors which influence cutting edge wear are wood components such as tannic acid or silicate inclusions. Natural tannic acids, such as those present in oak, lead to the chemical wear of tool cutting edges, particularly if the wood has a higher moisture content. Silicate inclusions, such as those present in tropical woods of Meranti, Teak or Mahogany, are absorbed from the ground along with nutrients and then crystallise in the vessels. They cause increased abrasive wear to the cutting edges. Large density differences between earlywood and latewood normally are a sign of strong presplitting and a tendency to splinter during processing (example: Pinus Radiata). The increasing global wood demand is the reason why trees are more and more bred in forest plantations. Those so called plantation woods are generally fast-growing species such as Radiata Pine, Eucalypts, and Poplars. These plants show rougher annual growth rings, lower density and strength in comparison with the plants grown in natural forests. Due to the stronger predisposition of trunk splitting and defibering sometimes the cutting of plantation woods presents a real challenge. It requires both special machining technology and special tool solutions. Long-fiber woods as Poplar are used as raw material for wood-based materials.

Type of wood	Bulk density [kg/m ³]	Strength [N/mm ²]		
		Compressive	Bending	Shearing
Hardwoods				
Afzelia	750 - 950	65 - 79	90 - 120	7.5 - 15.0
Maple	530 - 790	29 - 72	50 - 72	9.0 - 15.0
Balsa	90 - 260	5 - 15	12 - 23	1.1 - 2.0
Bangkirai	900 - 1100	68 - 80	125 - 140	10.0 - 15.0
Birch	510 - 830	38 - 100	147 - 155	12.0 - 14.5
Beech (Red Beech)	540 - 910	41 - 99	74 - 210	6.5 - 19.0
American Oak	550 - 980	39 - 61	89 - 130	9.0 - 14,6
European Oak	430 - 960	54 - 67	74 - 105	12.0
Alder	490 - 640	31 - 77	44 - 172	3.0 - 6.5
Ash	450 - 860	23 - 80	58 - 210	9.0 - 14.6
Eucalyptus	720 - 790	37 - 51	75 - 104	9.5
Iroko	550 - 850	52 - 81	70 - 158	9.5 - 12.5
American Cherry	525 - 615	33 - 59	59 - 98	15.0
Mahogany	450 - 620	36 - 70	50 - 130	6.0 - 9.5
Meranti, Dark Red	550 - 890	53 - 74	66 - 222	7.1 - 10.6
Meranti, Light Red	390 - 760	21 - 50	32 - 80	4.0 - 8.0
Merbau	760 - 830	60 - 85	140	13 - 17.5
Populus	410 - 560	26 - 56	43 - 94	4.0 - 8.0
Sipo	550 - 750	43 - 73	47 - 155	5.5 - 15
Teak	520 - 700	42 - 59	58 - 109	8.3 - 9.5
Coniferous woods				
Douglas-fir	640 - 800	43 - 68	68 - 89	7.8 - 10.2
Spruce	330 - 680	33 - 79	49 - 172	3.0 - 6.5
Pine	330 - 890	35 - 94	59 - 98	6.1 - 14.6
Larch	440 - 850	64 - 132	107	4.5 - 10.9
Radiata pine	450 - 580	36 - 65	60 - 91	6.8 - 7.6
Fir	350 - 750	31 - 59	47 - 118	3.7 - 6.3

Table: Bulk densities and strength values (moisture content: 12%) for established wood types (source: Holzatlas, Wagenführ, 2007)

The Brunell **hardness** of woods is tested at 12% moisture content. The hardness parallel to the fibres will be approximately double that perpendicular to the fibres. Because of the differing cell forms and varying structures within the wood, hardness figures can only be quoted as guidelines. They are, as for density values, highly dependent upon the moisture content of the wood.

Other physical properties which are of importance when working with wood are its **elasticity and strength**. Elasticity is a measure of the ability of a solid material to return to its original configuration from a distorted state (unit: E-modulus, N/mm²). When judging the strength of timber, it should be remembered that knots, splits, spiral grain and other structural idiosyncrasies have a significant effect on this property.

Moisture content plays an essential role in terms of how the wood is processed and the quality of the end product. Moisture content is the percentage of water in relation to the dry mass of the wood. In freshly harvested wood, water is both bound in the cell walls as well as contained in the vessels. Moisture content can be over 100% in this case. If the water has escaped from the cell vessels and is only present in the cell walls, then the term „fibre saturation point“ is used. This varies from wood type to wood type and is usually at around 30% moisture content. Below this saturation point, the wood shrinks and swells when moisture is released or added. With kiln dried wood, moisture content is 0. In order to achieve sufficient dimensional stability, the wood should therefore be dried before the finishing process so that the moisture content corresponds with the moisture content of the environment in which it will be used. This is known as the equilibrium moisture content. Indoors, this value is somewhere in the range of 6% to 12%, and is somewhere between 8% and 16% outdoors (without direct exposure to the elements). Moisture content needs to be between 12% and 14% for the best possible woodworking conditions. Below this value, the wood has a greater tendency to split, and above this the surface roughness is increased through shrinkage during final drying.

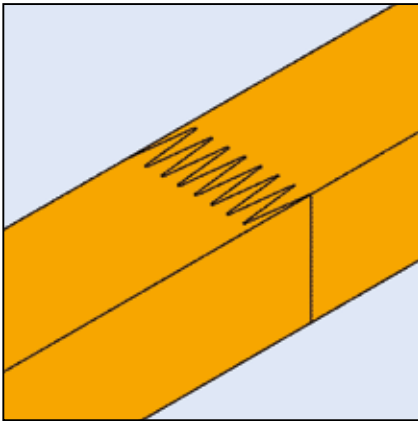

Structural solid wood (KVH)

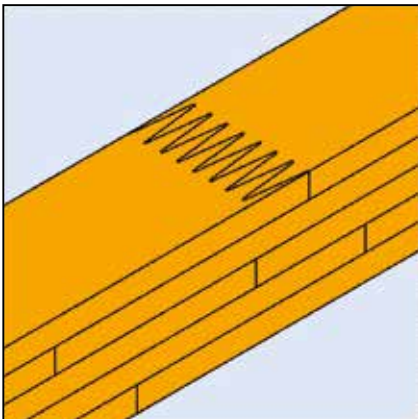

Laminated timber (BSH)



Modified wood (examples)
Accoya®, thermal beech, Belmadur®

Due to its limited dimensions, its swelling/shrinkage and its inhomogeneity from knots and branches, solid wood is usually further refined into **semi finished products**. With structural woods, weak points such as branches or cracks are cut out. Through finger jointing on the end grain edges, components can be manufactured to be any required length. By laminating planks or boards parallel to the wood fibres, larger component cross sections can be created and strength increased. Products in this area include solid structural timber and glue laminated timber. For window frames, for example, the laminated strips can be manufactured using a wide range of wood types with a variety of properties.

Modified woods

A large number of modification techniques have been developed and tested over the past few years in an attempt to identify suitable methods for making woods which are available in sufficient quantities dimensionally stable and weatherproof for use outdoors. Pinus Radiata, for example, is stabilised through an acetylation process (Accoya®). Pine is treated with a pressure impregnation process (Belmadur®). Dimensional stability and weatherproofing of thermotreated wood is generated through a pyrolysis process.

One common factor in all of these techniques is that they do not just have an effect on areas near the surface of the wood, but on the material as a whole. These techniques have created „new types of wood“ with minimal swell/shrink behaviour, increased hardness and modified woodworking properties. Cutting forces and wear are lower than with natural woods. Brittleness and dust formation during processing are higher, but these factors do not cause any fundamental limitations.

All materials which are manufactured from wooden structural elements, such as panels, veneer, chips or fibers, are known as wood derived materials in both lay and specialist terminology. Wood derived materials started being developed in the 1920s. Then, large, flat pieces of wood with different thicknesses were bonded and pressed together with the fibres running in different directions. Plywood panels and multiple layer panels opened the way for new designs and construction opportunities.

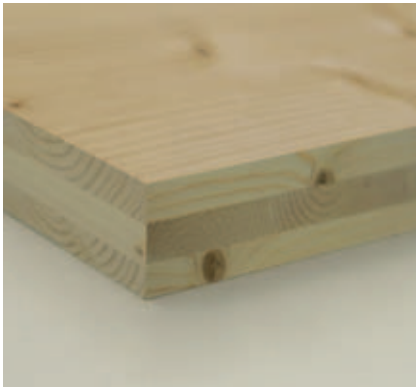

Cross laminated timber CLT

After 1950, an independent woodchip material industry developed on a global scale from the beginnings of chipboard manufacture in the 1930s. This industry concentrated on panels or moulded parts made from the chips or fibres of hardwoods and coniferous woods, and also of lignified annual plants (such as straw or flax). In the DIN 4076 standard, wood based panels are classified by type, structure and bulk density. The manufacture of wood based panels allowed the development of furniture manufacture on an industrial scale.

Today, wood materials are roughly divided into:

- **Solid wood and veneer materials:**
such as laminated timber, plywood, veneer plywood or multiplex boards
- **Woodchip materials:**
such as flat-pressed panels (chipboard), particle boards, oriented strand boards (OSB)
- **Wood fibre materials:**
Medium-density fibreboard (MDF), high-density fibreboard (HDF), hard fibreboard or wood fibre insulation boards
- **Wood composites:**
such as wood plastic composites (WPCs); light weight building slabs – high-strength surface layers with a soft core of foam, balsa wood or honeycombs of cardboard or plastic; synthetic resin compressed wood (armourply) – compressed materials made from beechwood veneer and synthetic resin (bulk density: 900 – 1400 kg/m³)



Particle board

The objective with all these wood materials is to generate a material which is isotropic in at least two dimensions, despite the anisotropic properties of wood. A layer structure which is symmetrical with the midplane of the board is an important pre-requirement to guarantee warp free boards.

With **solid wood and veneer materials**, quasi-isotropic properties are obtained through the individual layers being bonded together parallel to their fibres. During the woodworking process with such materials, the tools must be configured for simultaneous processing both parallel and perpendicular to the fibre direction. The glued joints usually generate the highest tool cutting edge wear.

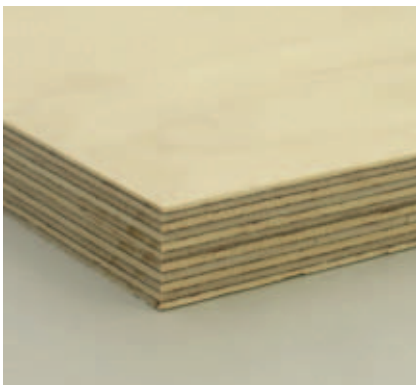

Veneered plywood

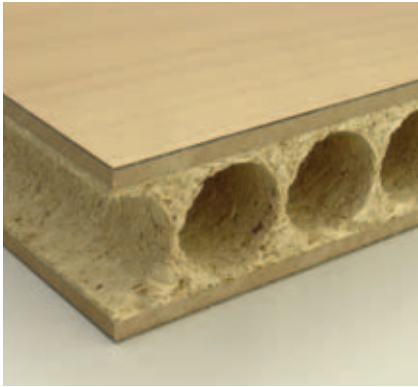

Extruded chipboard as heart of a composite material



Chipboard, plastic coated

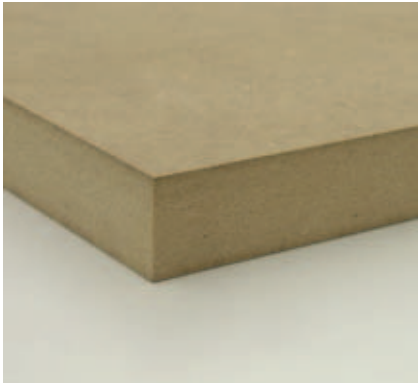

MDF board

Chipboards are divided into two different categories, flat pressed panels or particle boards, depending on the pressing method used. With flat pressed panels, the woodchips are primarily oriented in the direction of the panel. A variety of layers with a variety of properties can be manufactured by changing the size of the woodchips. Usually, panels are manufactured as three layer panels. The middle layer has large woodchips whereas the two outer layers have finer woodchips giving a smooth surface. In contrast, woodchips in particle boards lie predominantly perpendicular to the direction of the panel. They have the same structure through the entire cross section.

Chipboards are classified by strength and moisture resistance to DIN EN 312-1.

General use (non load-bearing function)	General use, also for load-bearing components	Heavy duty for load-bearing components
P1 for light panelling in dry areas	P4 dry areas	P6 dry areas
P2 for furniture and interior fittings in dry areas		
P3 in moist areas	P5 moist areas	P7 moist areas

Fungicides and flame retardants can also be added to the boards during the manufacturing process.

The most important features of chipboards are, however, their bulk density and their strength. Heavy chipboards (such as flat pressed panels), widely used in furniture and interior fittings, have a bulk density of between 450 and 750 kg/m³. During storage of the wood, non wood materials such as sand and small stones enter the manufacturing process, meaning that chipboards have a certain level of sand content. Sand content and particle size play a vital role in tool wear, which is why diamond tools are predominantly used in industrial processing. The shortage of raw materials has resulted in waste wood increasingly being processed into chipboard which means that the proportion of impurities in the wood is increasing.

The large number of particle boards' variations depending on their composition and the related properties as lacking distortion and decorative coatings explains the frequent and versatile use in furniture manufacturing and interior fittings.

Alongside woodchip materials, **wood fibre materials** are also classified according to their composition and method of manufacture. Porous fibreboards with a bulk density above 230 kg/m³ as well as medium hard, hard and extra hard fibreboards with a bulk density up to 800 kg/m³ are manufactured from wood or other lignocellulose fibrous raw materials. The range of board variations, regarding their composition and properties achieved as a result, their low warping properties and decorative layering, are the reasons why they are so widely used and in such a diverse manner in furniture construction and interior fittings.

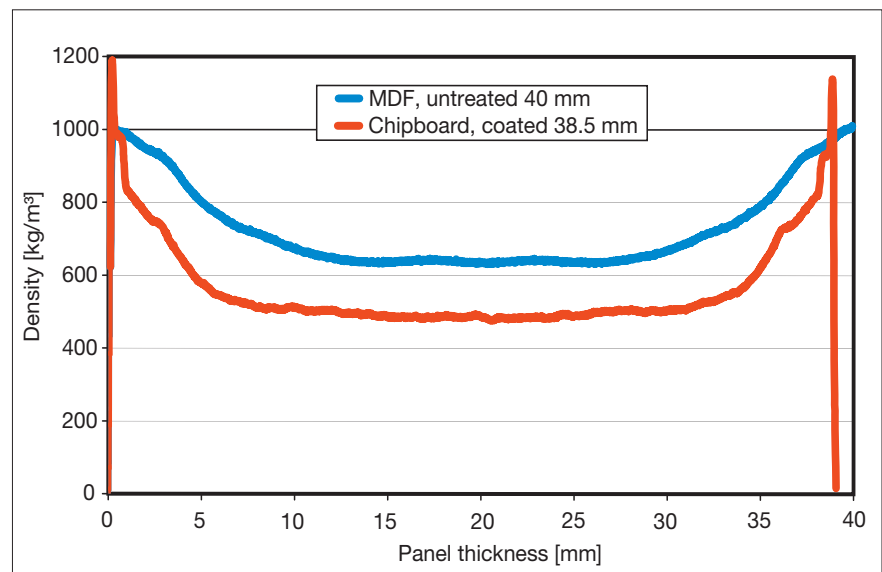

Density profiles of chipboard and MDF

„**Medium-density fibreboard**“ (MDF) became more and more important in furniture and interior fittings constructions in the 1980s as a further development of woodchip and wood fibre materials. Just like solid wood, the surfaces and edges of MDF panels can be profiled and finished as a result of their homogenous structure. They are predominantly manufactured from bark free coniferous wood which undergoes several phases of preparation to turn it into dry ultra fine fibres. This substance is then pressed together with glues which are low in harmful substances to create a panel with a roughly constant density. Bulk density is usually somewhere between 600 kg/m^3 and 1000 kg/m^3 . According to DIN EN 316 there are three different types: HDF ($\geq 800 \text{ kg/m}^3$), light MDF ($\leq 650 \text{ kg/m}^3$) and ultra-light MDF ($\leq 550 \text{ kg/m}^3$).

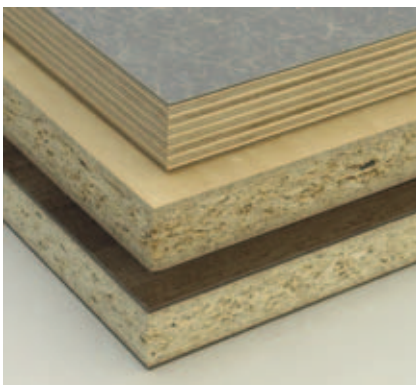

Coated panel material

When processing with machine tools, the **type of coating** must also be kept in mind alongside the physical and chemical properties of the materials. All types of wood materials are usually delivered as a finished product with some kind of coating. Surface finishes range from veneer and paint to paper and plastic of various thickness and hardness. Typical examples of the latter category are melamine resin or HPL (high-pressure laminate) coatings. The hardness and structure of the coatings mean that cutting geometries need to be adapted to ensure tear free processing. Overlays of laminate panels, which contain corundum particles to increase abrasion resistance, generate the highest levels of cutting edge wear.

Wood materials, with their wide range of specifications, have, like no other material, changed the way products are designed and the way materials are processed. Every new type of material brings with it new demands in terms of machinery and tools. Tear free cutting edges and precise profiling must be achieved with efficient manufacturing methods. Every further development with wood materials therefore leads to new and specially adapted tool designs and, if necessary, new processing methods.



Thermoplastic plastics
(solid material)



Extruded plastic profiles



Polymer clumping in the case of
thermoplastics (schematic diagram)



Gloss cut section on PMMA workpiece

Plastics consist of interwoven molecule chains, polymers, which in turn are composed of repeating structural units called monomers. The type of polymer bond determines the plastics properties. There are three main groups: thermoplastics, thermosets and elastomers.

Two common factors for all plastics are a low density and low thermal conductivity. The different properties of different types of plastics must be taken into account in machining work. High quality, efficiency and production security can only be achieved with tools and machining parameters specially customised to the material.

Thermoplastics

In thermoplastics, the molecule chains are crosslinked. A typical characteristic of thermoplastics is that they have a temperature at which they soften. Once a thermoplastic is heated above this temperature, it is soft and can be formed and shaped. Below this temperature (specific to a particular thermoplastic) thermoplastics retain their original shape. Thermoplastics can be used in a number of processes – injection moulding, extrusion and press forming.

Thermoplastic plastics also can be strengthened by fibres in order to increase density. Normally this involves short fibres so that the extrudability is continued. This technology for example is used for window profiles so that a reinforcement with steel inserts can be renounced.

The temperature at which thermoplastic starts to soften is around 60°C (depending on the specific plastic), a temperature relevant to the machining process. Exceeding the softening temperature during machining is detrimental to the machined quality. The chips melt, the tools become sticky, and both quality and production are no longer consistent. As well as specific tooth geometries and tool chip gullets, selecting the machining parameters is of utmost importance. Permitted cutting speeds are usually lower than those permitted with woodworking.

Transparent thermoplastics such as PC and PMMA require special processes. A transparent cutting surface is often required. This means having a totally smooth cutting edge with no visible cutter marks, a special cutting geometry and, of course, stable machinery with good clamping. A high quality cut can be achieved with polished tungsten carbide cutting tools. Monocrystalline diamond is the preferred choice for completely glossy surfaces. If these measures are not taken, the result is a matt cutting surface.



Structure of thermosets
(schematic diagram)



Compact laminate panel

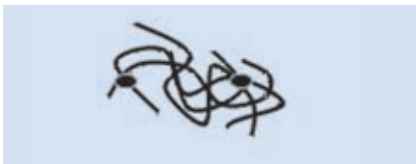

Structure of elastomers
(schematic diagram)

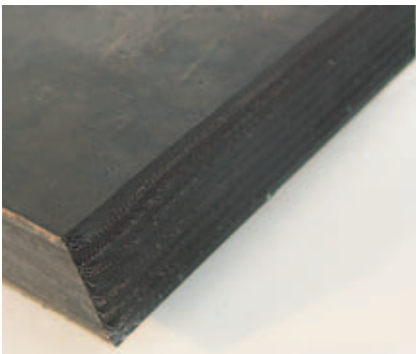

Elastomer with fabric insert

Thermosets

In thermosets, the molecule chains are irreversibly cured at cross linking sites, or nodes, through chemical bonds.

When a thermoset is heated up, the monomers begin to move. The intensity of these oscillations increases as the temperature rises. When the temperature rises above a critical point, the nodes are irreversibly broken. As a consequence, thermosets are destroyed at a temperature specific to the material – the pyrolysis temperature – which is above 150°C. Thermoset materials are usually moulded or, in the case of composites, pressed. They are usually hard and brittle.

To improve the properties of thermosets, **reinforcement materials** in the form of laminated paper, fibreglass, carbon fibre or aramid fibre are incorporated into the thermoset mass. The different combinations of these materials have been given new grade designations such as FR-2, FR-3, FR-4, CEM-1, CEM-3 etc. (for example, FR-4 is glass reinforced epoxy laminate).

Typical examples for duroplastic working materials are for example compact laminate panels or high pressure laminates (HPL laminates) of melamine - or phenolic papers, printed circuit boards (PCB) or PU-foam.

The focus is not on the temperature during the machining process. The cutting speeds are higher than those for thermoplastics. Due to the hard brittle material properties and the abrasive effect of the embedded fibres, tools used in conjunction with thermosets require different geometries and cutting materials than those used to process thermoplastics.

Elastomers

Elastomers are soft plastics, more commonly known as „rubber“, which can be shaped and then go back their original form when released. This particular property is due to the wide meshed structure of the molecule chains. They do not soften when heated. Machining is possible, but rare. The main difficulty is clamping the workpieces.

Mineral constituents are attached to board materials using a bonding agent. The materials have specific properties depending on the proportion and type of bonding agent and mineral constituents. Compared to wood materials, the cutting speed for mineral materials must be decreased.



Mineral working material

Polymer bonded mineral materials

(e.g. Corian, Hi-Macs, Kerrock, Noblan, Surell, Varicor, Velstone)

Two thirds of these materials consist of natural minerals (e.g. aluminium hydroxide, feldspar) which are bonded in an acrylic polymer (PC) matrix. The material can be shaped at high temperature due to its high proportion of acrylic. The proportion of mineral materials raises the softening temperature of the plastic, which makes machining easier. These materials are mainly machined using tungsten carbide or polycrystalline diamond cutting tools. Very large mineral particles can damage diamond cutting edges so, as a result, tungsten carbide cutting edges are recommended in this case.

Polymer bonded mineral materials are available as panels with a thickness between 4 mm and 20 mm, and as moulded parts (e.g. wash basins). They are usually applied to wood based panels and can be joined by adhesion and flush trimming. Large scale components can be manufactured using this process. To obtain straight and scratch-free saw cuts, AS foil vibration damped sawblades are recommended.



Perlite panel

Perlite-based fire protection board

A characteristic of this material is that it has a highly abrasive action on the tool body. Circular sawblades' bodies are particularly vulnerable to this problem. The gullet is eroded and as a result, the tooth breaks away although the carbide tip has not reached the wear limit. That is the reason why the use of special tool design with wear-protected basic-bodies and jaws are recommended.

Regular and fibre reinforced plaster board

These materials are machined in dry and „wet” condition. In the wet condition, tungsten carbide is recommended as a cutting material. Diamond is suitable as a cutting material for dry but not wet machining.



Plaster board / gypsum board

Fibre reinforced cement slabs

One of the special properties of fibre reinforced cement panels is their high density. If unsuitable machine parameters are chosen, sparks may occur during machining. Tungsten carbide has only a short run time; thence diamond is preferred as cutting material even by power-driven hand tools or high-volume work.

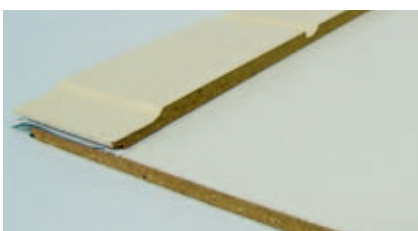

Cement fibre board

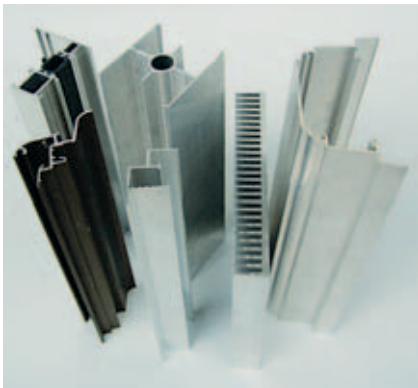

Aluminium extruded sections

Wrought aluminum alloys are the most common examples of **non-ferrous metals**. They exist as hollow or full profiles, as sheets or as surface layers or intermediate layers in wood materials.

Silicon is added to increase machinability. Si content $\geq 12\%$ leads to increased cutting edge wear which is why diamond cutting edges are recommended. If the Si content $\geq 12\%$, the aluminum tends to „fuse“ to the cutting edge during machining and this quickly leads to build up on the edges. Tungsten carbide should be used, if possible, together with coolants (minimum quantity lubrication – MQL).

Tools with diamond cutting edges (PCD) are particularly suitable for dry machining. Build up on edges are avoided and better machining quality is achieved due to the extremely high thermal conductivity and low friction values of diamond. Sawblades with specially shaped teeth and small cutting angles (some negative) are employed in cutting hollow profiles to avoid the teeth hooking the thin web. Foil saws are particularly suited for scratch-free trim and mitre cuts due to their good vibration damping properties.

A **composite** consists of two or more materials which are combined to produce different material properties. Composites have different properties to the materials with which they are combined.

Essentially, there are two groups:

Composite layered materials, such as:

- Composite panels (e.g. plywood or wood core boards)
- Sandwich panels (stable outer layers with a soft core)
- Honeycomb panels
- Chipboards with aluminium barrier layers (vapour barrier)
- Window frames with insulation material as a middle layer
- Floor panels with a HDF core and a variety of surfaces (PVC, cork, felt®)

Composite fibre materials, such as:

- Carbon fibre reinforced plastic (CFRP)
- Glass reinforced plastic (GRP)
- Aramid fibre reinforced plastic
- Natural fibre reinforced plastic
- Wood plastic composites (WPC)
- Fibre cement boards

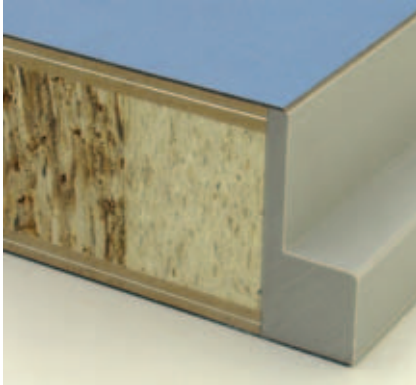

Layer composite working material

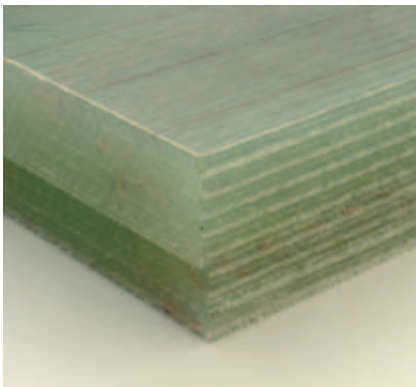

Fibre composite working material

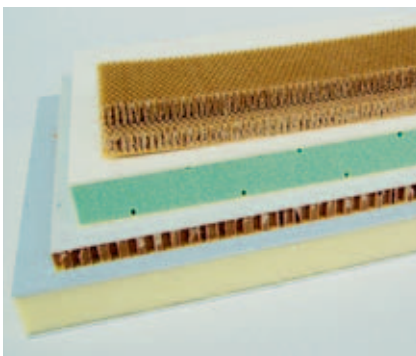

Lightweight working material with honeycomb or foam core

The difficulty in terms of machining is a result of the often conflicting requirements of the individual material components concerning the cutting edges, meaning the tools usually have to be specially designed for particular composites. In the case of composite layered materials, a variety of cutting materials can be employed at the same time to machine the different layers (so called hybrid tools). Because of the different strengths of the individual components, there is often the risk of delamination from the cutting forces.

11.2 Cutting materials

Profit is made at the cutting edge! Wear resistant cutting materials with sharp cutting edges guarantee long tool life and high surface quality. The full potential of a cutting material needs the correct cutting edge geometry, and in turn, is dependent on the machining process and the properties of the material being shaped.

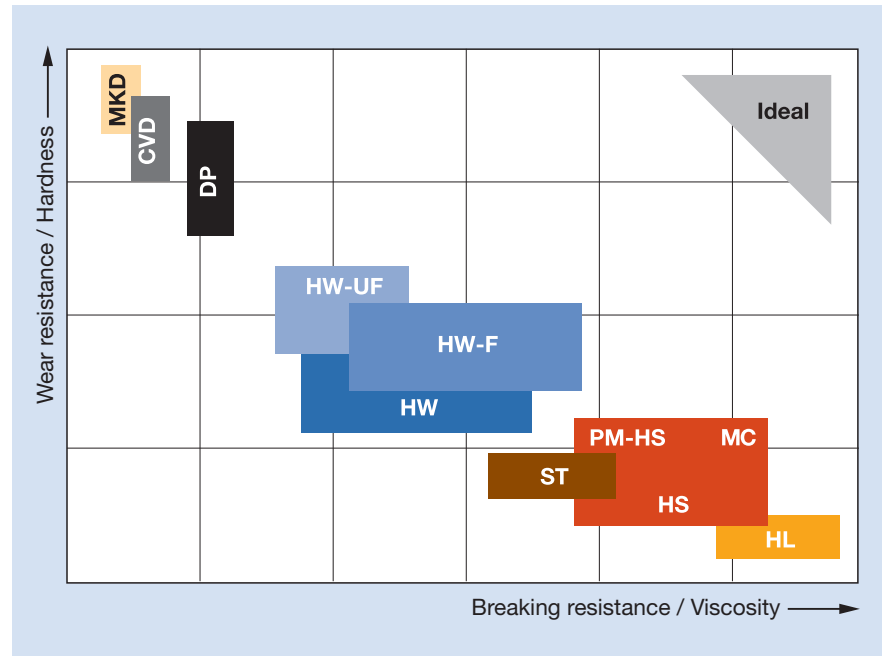

Cutting materials for processing wood and plastics

The ideal cutting material should be hard and tough at the same time, but an „all-purpose material” of this kind simply does not exist. Today the choice of woodworking cutting materials range from tough tool steel to the hardest material in the world, diamond. The wide variety of workpiece materials and tool designs need all of these cutting materials:

Diagram: Classification of the tungsten carbides in cutting groups as per ISO 513
 K-grade: WC + binders
 P- and M-grade: Additionally with WC-TiC and WC-TaC mixed crystals for higher temperature strength

Group	Application / working material	Code	Hardness	Viscosity
P	Steel, steel casting, long-chipping, malleable iron	P01	↑	↓
		P10		
		P20		
		P30		
		P40		
M	Steel, steel casting, austenitic manganese steel, austenitic steel, free cutting steel, alloyed grey iron	M10	↑	↓
		M20		
		M30		
		M40		
K	grey iron, chilled iron, short-chipping malleable iron, hardened steel, non-ferrous metals, plastics, wood, wood-derived materials	K01	↑	↓
		K05		
		K10		
		K20		
		K30		
		K40		

11.2 Cutting materials

Cutting material with abbreviation	Composition, manufacture	Characteristics and possible use
SP Alloy tool steel	alloy content < 5% (C > 0.6%). Few carbides, therefore only low hardness and heat resistance. Manufactured in a molten-metallurgical process.	Hardenable up to 60 HRC. For solid wood processing in the craft sector, e.g. as a profile knife for universal cutterheads.
HL High-alloy tool steel	alloy content > 5% Alloy elements Cr, Mo, W and carbon form carbides which allow for hardness and wear resistance. At least 1 alloy element > 5% e.g. B 12% Cr and 2% C. Manufactured in a molten-metallurgical process.	Hardenable up to 63 HRC. Very corrosion resistant from high Cr content. Preferably used in planing mills for soft woods, e.g. solid cutter for manufacturing tongue and groove boards at high feed speed.
HS High performance high speed steel (HSS)	alloy content > 12% Alloy elements W, Mo, V, Co and carbon form carbides which allow for hardness and wear resistance. Manufactured in a molten-metallurgical process, followed by machining processes - linear distribution of the carbides manufactured in a powder-metallurgical process (PM-HS) - higher alloy contents possible, homogen distribution of carbides.	Hardenable up to 65 HRC. Preferably used for solid wood processing, mainly soft woods, e.g. planers, jointing cutters, profile blanks or tipped profile cutters. Considerably longer tool life compared to HL steel. The best relation between toughness and hardness is achieved with HS steel manufactured in a powder-metallurgical process (PM HS).
ST Cobalt-based cast alloys	Almost completely non-ferrous alloys of: Co, W, Cr. Manufactured in a melting process.	Hardness 40 to 58 HRC. Particularly corrosion and temperature resistant, tough (small cutting angles possible). Typical applications: Processing of fibrous or damp, acidic woods in sawmills or planing mills, and machining oak, Meranti or poplar.

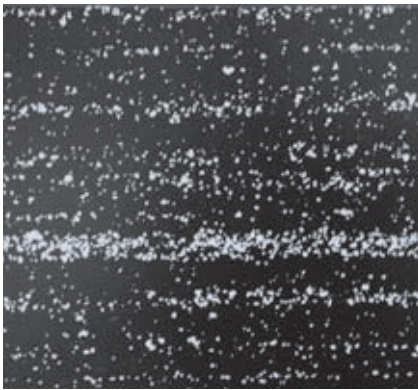

Roco-shaped structure for melting made HS steel

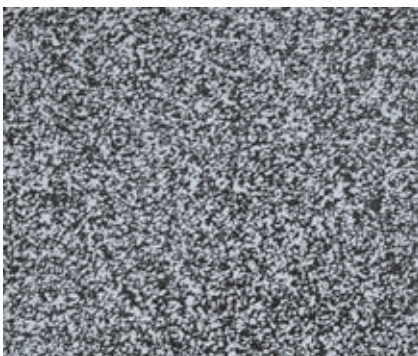

Homogenous structure for PM-HS Steel



11.2 Cutting materials

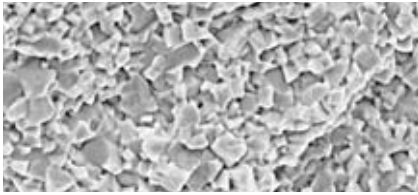

Fracture of a standard tungsten carbide.

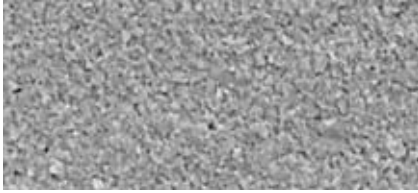

Fracture of an UF-tungsten carbide.



Sharp-edged wear on a coated HS edge.

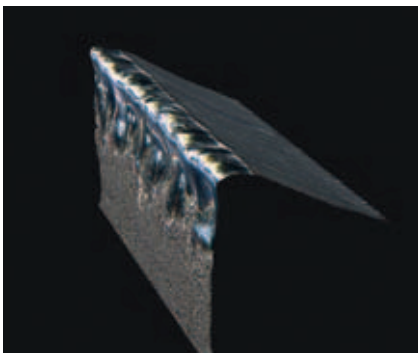

Rounding- and erosion wear on an uncoated HS edge.

Cutting material with abbreviation	Composition, manufacture	Characteristics and possible use
<p>HW Carbide metals</p>	<p>Sintered materials composed of metal carbides and metallic binders (mainly WC + Co).</p> <p>Manufactured in a powder-metallurgical process by mixing and pressing the basic powder materials, followed by sintering at high pressures and temperatures.</p>	<p>Hardness between HV 1300 and 2500.</p> <p>Hardness and toughness can be varied over a wide range by altering the grain size and quantity of the binder in the mix.</p> <p>Universal cutting material for wood processing with wide range of application from knotty softwood with glued joints to panel materials and solid plastics. Ultra fine carbide metals allow for very sharp cutting edges as a prerequisite for paintable surfaces.</p>
<p>SC (MC) Steel, coated</p> <p>HC Tungsten carbides, coated</p>	<p>2 – 3 µm thick hard material coating on the blade.</p> <p>Coating materials: Nitrides, carbides, carbon nitrides or oxygen nitrides from the elements Ti, Al, Cr, Zr.</p> <p>Manufactured in a vacuum coating process.</p> <p>A new cutting material is created by the coating. The substrate is no longer solely responsible for the wear resistance but assumes a supporting function for the coating.</p>	<p>Surface hardness between HV 1600 and 3500.</p> <p>The chemical and abrasive wear resistance of the substrate at the surface of the blade is significantly increased. The edges remain sharp longer and friction is reduced. Performance times can be improved five fold compared with uncoated tools. This performance is retained even after sharpening.</p> <p>Preferred applications: solid wood, thermoplastics, non-ferrous metals</p>

11.2 Cutting materials



DP edge polycrystalline diamond layer (on top) sintered on to a tungsten carbide substrate (on bottom)

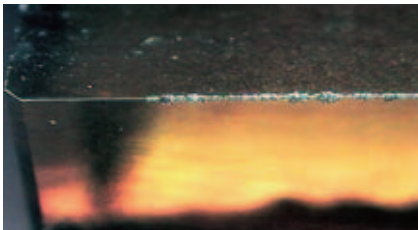

DM edge - monocrystalline synthetic diamond

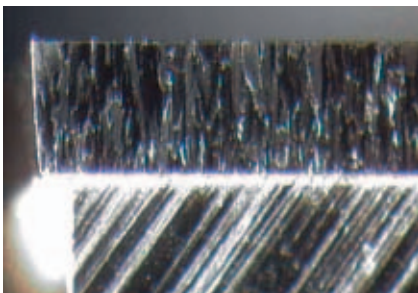

CVD diamond layer of columnar diamond crystals, soldered on tungsten carbide

Cutting material with abbreviation	Composition, manufacture	Characteristics and possible use
DP Polycrystalline diamond (PCD)	Sintered layer (0.3 – 0.6 mm) composed of diamond crystals on tungsten metal surface. Diamond grain size: 1 – 30 µm. Manufactured in high-pressure synthesis process. Diamond grains sinter among each other forming a layer and are combined with a tungsten carbide substrate. Due to the diffusion of Co from the tungsten carbide between the diamond grains, the diamond becomes conductive and may be processed by spark erosion.	Composed of the hardest material, wear starts at grain boundaries, very good thermal conductivity. Hardness and toughness can be varied within certain ranges by altering the grain size. The field of application of DP cutting materials ranges from solid woods, chipboards and fibre boards to very abrasive materials such as fibre cement boards, laminate floors or fibre reinforced plastics (composites). Excellent suitability for dry processing of non-ferrous metals.
DM Monocrystalline diamond	Diamond monocrystal (structure with grain boundaries). Manufactured in a high pressure synthesis process. Only available in dimensions of a few millimeters. Processing only possible by grinding with diamond.	Harder than DP. Very smooth cutting edges can be produced as there are no grain boundaries. Can be used for very abrasive laminate overlays or for a polished finish on plastics and non-ferrous metals.
CVD Polycrystalline diamond layer	0.5 mm thick diamond layer composed of columnar diamond crystals grown together, brazed on a tungsten metal support. Manufactured in a plasma CVD coating process. Due to doping with boron, conductible and erodable.	Harder than DP and DM as there is no metallic binder phase and the diamond grains with their crystal grid layer levels are positioned randomly. Used for particular laminate's overlays.

11.2 Cutting materials

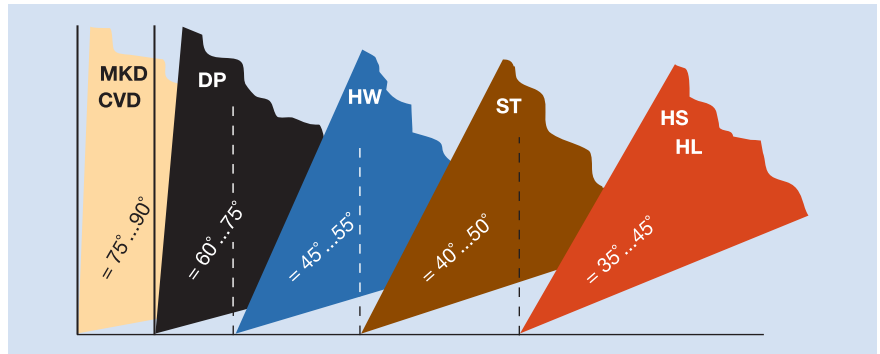

Specific cutting material geometries

Due to the relation between hardness and toughness, there is a specific angle geometry for every cutting material to achieve optimum cutting performance. Hard, brittle cutting materials require a stable wedge angle so the edges cannot break off. Less hard, but tougher cutting materials require larger cutting angles to maintain a cutting edge. Tungsten carbides offer the highest degree of design freedom and can be used for almost every application.

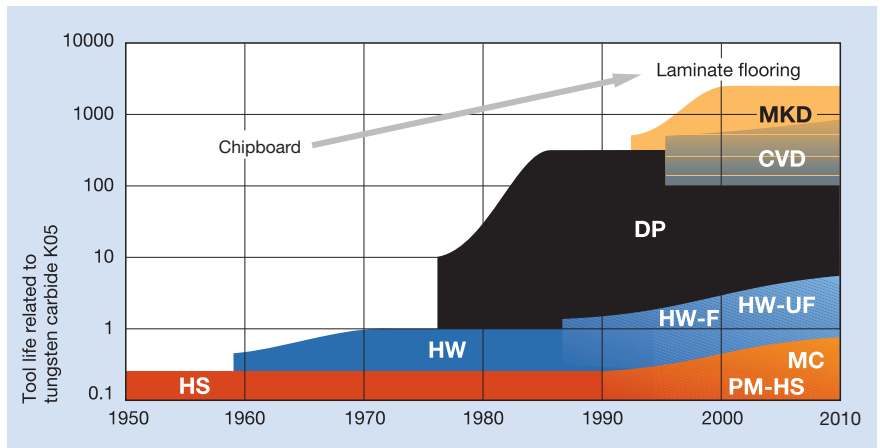

Progress in tool life by different cutting materials

All cutting material developments are aimed at longer tool life. New work piece materials often call for new cutting materials. Chipboard led to the use of tungsten carbide and later to polycrystalline diamond, laminate flooring to monocrystalline and CVD diamond and plywoods to fine grain tungsten. In the 50 years of panel material development, tool life has increased a thousand fold.

11.3 Fundamental cutting principles

11.3.1 Essential geometry elements in a cutting tool

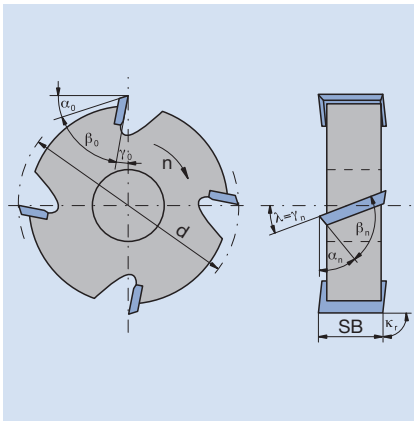

Cutting geometry and description of angles

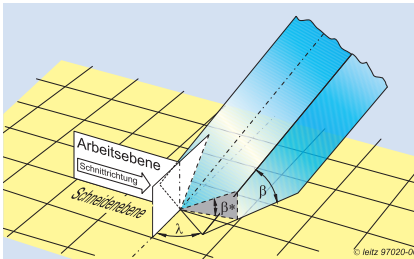

„Shear cut“ - the shear angle effectuates a reduction of the wedge angle in cutting direction

Größe	Symbol	Bedeutung
Cutting angle (Gamma)	γ	Influences cutting force and pre-splitting. For cross grain and tough materials rather large cutting angles, for hard, brittle materials rather small cutting angles.
Wedge angle (Beta)	β	Important for cutting edge stability. Cutting material specific minimum wedge angle required, so that cutting edge does not break off.
Clearance angle (Alpha)	α	Reduces friction between blade and workpiece and resin build up.
Shear angle (Lambda)	λ	Creates a „pulling cut“. Acts as cutting angle for the leading secondary cutting edge (cutting flange). Influences the chip flow in axial direction.
Edge setting angle (Kappa)	κ_r	Enlarges the start of the cutting angle of the blade. For edge setting angles $< 10^\circ$, almost no cutting actions can be seen (e.g. edging tools).
Secondary cutting edge angle	γ_N	Corresponds to the shear angle of the main cutting edge.
Leading edge angle	β_N	Important for the stability of the secondary cutting edge. Normally larger than the secondary wedge angle of the main cutting edge.
Secondary cutting edge clearance angle	α_N	Reduces friction between secondary cutting edge and workpiece and resin build up.
Diameter	d	Regarding profile tools, the zero diameter (mostly the smallest diameter) sets the processing position of the tool. The maximum diameter is set by the permissible rotational speed n_{max} and for collision factors.
Cutting width	SB	Determines the maximum processing width of the tool.

11.3 Fundamental cutting principles

11.3.2 Cutting directions and procedures when cutting wood

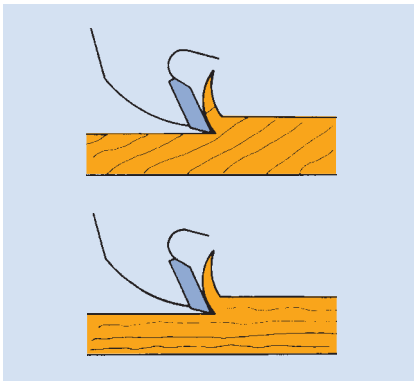

Longitudinal cut with the grain

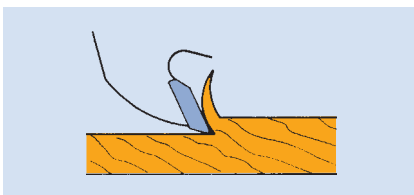

Longitudinal cut against the grain

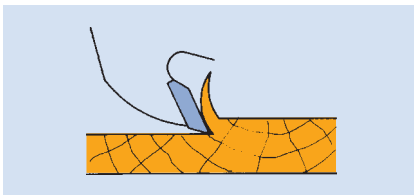

Cross-cut

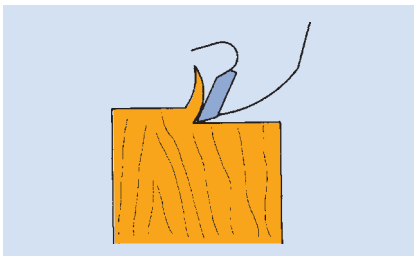

Cutting in end grain

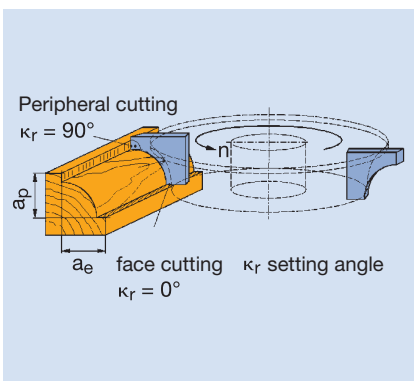

Cutting procedure on the example of „profile cutting“

Due to the anisotropy of the wood as a naturally grown material, it can basically be divided into **three cutting directions**:

a) Cutting along the grain

1) With the fibres

Easy to cut. Excellent surface quality and high feed rates possible.

2) Against the fibres

Difficult to cut, as the fibres tend to lift. If possible this cutting direction should be avoided by using alternatives, for example changing the direction of rotation (against feed/with feed).

b) Cutting across the grain

Low cutting forces, but the surface finish is slightly rough surface as wood fibres are „peeled off“.

c) Cutting the end grain

The fibres are cut vertically to the fibre direction. The result are high cutting forces and slightly rough surface finishes. When the cut is completed, fibres may be torn out which is why it is cut with smaller tooth advances and using against a wood backing piece.

In the case of knotty wood and around branches, all cutting directions may occur at the same time. Due to specific cutting techniques and tool designs for pre- and finish-cutting, a continuously good processing quality is achieved.

Due to the cutting surface area there are different **cutting applications**:

a) Peripheral cutting

The circumference of the cutting tool machines the workpiece. The circumference of the tool is surface determining. The tool's axis of rotation and the surface of the workpiece are vertical to each other. The enclosed angle, $\kappa_r = 90^\circ$, is called the setting angle.

Examples: planing, jointing.

b) Surface planing

The face of the cutting tool machines the workpiece surface. The front face of the tool is surface determining. The tool's axis of rotation and the workpiece surface are parallel to each other. The enclosed angle (setting angle) is $\kappa_r = 0^\circ$.

Examples: cutting, circular saws, edging.

c) Profile cutting

Profiling is a combination of peripheral and face cutting, irrespective of whether the tools have shanks or bores. In general, there is a smooth transition from peripheral to face cutting in profiling. Any setting angle between $(0^\circ \leq \kappa_r \leq 90^\circ)$ can occur.

Examples: round profiles, finger profiles or any decorative profiles - but also bevelling, rebating, grooving or slotting.

11.3 Fundamental cutting principles

11.3.2 Cutting kinematics

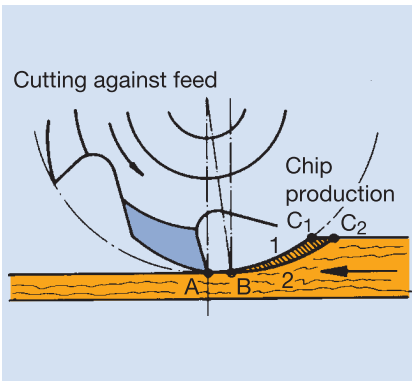

Chip formation when running against feed

a) Cutting against the feed

The direction of the tool cut is opposite to the direction of workpiece feed. Initially the cut has zero thickness. Before a chip can form and move across the cutting surface, the cutting edge presses against the workpiece at the start of the cutting angle. The final workpiece surface is created during this initial phase. As the cutting action increases, the cut becomes more stable with the increasing cut thickness. The final stage of the cutting process is when the chip breaks away; this is known as pre-splitting.

AB: friction zone.

B, C1, C2: elongated chip.

Advantages:

Pre-splitting can help reduce cutting forces, the required motor power, and increase tool life. A lower drive output is required.

Disadvantages:

If the direction of the fibres and the pre splitting direction runs from the cutting edge toward the „go” side of the workpiece, pre-splitting creates a rough surface with torn fibres.

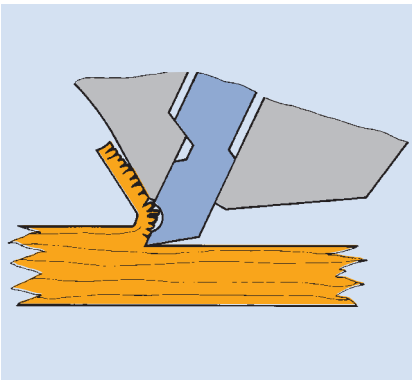

Effect of a chip breaker

A chip breaker ahead of the cutting edge helps form the chip earlier and reduce pre-splitting.

Since there are constantly changing fibre and feed directions during stationary machining on CNC machining centres, special cutting techniques are necessary to avoid unfavourable fibre cutting angles.

b) Cutting with the feed

For mechanical feed only.

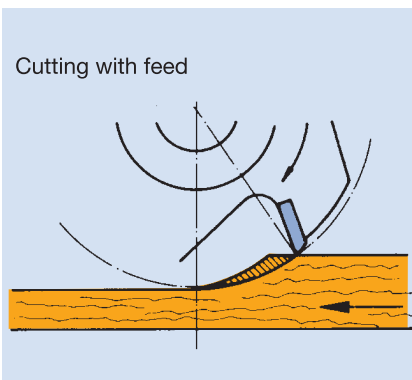

Chip formation when running with feed

The tool cutting direction is the same as the direction of workpiece feed.

Cutting starts at the maximum chip thickness, falling to zero by the time the cut is completed. With increasing cutting action, the chip becomes thinner and finer and with less risk of pre splitting.

Advantages:

Comparatively good surfaces are obtained when there is an unfavourable fibre direction. Lower feed forces required, allowing an increase in the feed speed.

Disadvantages:

The cutters are subject to more severe loads and wear quicker because of the reduced pre splitting. The tool life is approximately 30% shorter compared to cutting against the feed.

There is the danger of tool kick back that means hooking of the cutting edges and acceleration of the workpiece to cutting speed. Cutting against the feed is recommended for manual feed to prevent accidents.

During the peripheral cutting process (e.g. planing, jointing, profiling), the workpieces's surface finish is produced by the peripheral blades. By superimposing tool rotation on the linear feed movement of the workpiece, a succession of cutting actions produce a wave effect on the surface of the workpiece. The pitch, depth and uniformity of these planing or cutter marks determine the machined surface quality. The dimensions of the cutter marks are a combination of the cutting radius, the effective number of teeth, spindle rotating speed and feed rate.

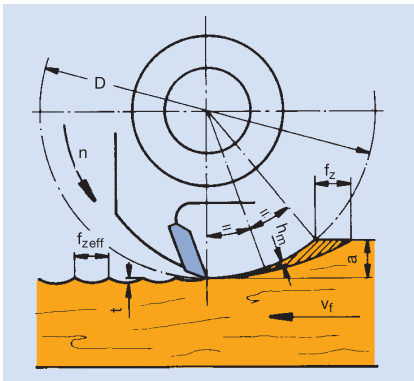

Finish formation and cutting sizes on the example of „chamfering“

These considerations also apply to face cutting tools such as cutters or circular saw blades. The concentric run-out is replaced by the axial run-out.

Terms and formulae relations:

$v_c = \pi \cdot D \cdot n / (1000 \cdot 60)$	Cutting speed [$m \cdot s^{-1}$]
$n = v_c / (\pi \cdot D) \cdot (1000 \cdot 60)$	Speed of rotation [min^{-1}]
$v_f = f_z \cdot n \cdot Z / 1000$	Feed rate [$m \cdot min^{-1}$]
$f_z = v_f / (n \cdot Z) \cdot 1000$	Tooth advance [mm]
$f = f_z \cdot z = v_f / n \cdot 1000$	Feed per rotation [mm] cutter mark length of jointed tools
$f_{z\text{eff}} = f_z \cdot 1 = v_f / n \cdot 1000$	Effective tooth feed visible on the workpiece [mm] (cutter mark length) [mm]
$t = f_z^2 / (4 \cdot D)$	Depth of knife marks [mm]
$h_m = f_z \sqrt{a_e / D}$	Mean cutting thickness [mm]
$a_e =$	Radial cutting action, cutting depth [mm]
$a_p =$	Axial cutting action, cutting width

These formulae have numerical values.

All values must be entered using the units of measurement shown in the square brackets [].

Top quality surfaces have cutter marks at a regular pitch between 1.3 and 1.7 mm. As the cutter mark length increases, surface finish quality deteriorates but tool life increases. As the cutter mark length decreases, the mean cutting thickness h_m decreases as well. As a result, friction and wear increase and tool life decreases.

Single knife finish

Due to the production tolerances, the cutting edges on a multi-knife tool do not all have the same cutting radius. With conventional tool clamping (clearance fit between spindle and tool), only one cutter normally creates the workpiece surface. This is known as a single knife finish. The other cutting knives contribute to the cutting process, but do not determine the finish surface quality of the workpiece. The cutter that projects farthest removes traces of the cutting action of the other cutters.

11.3 Fundamental cutting principles

11.3.4 Processing quality

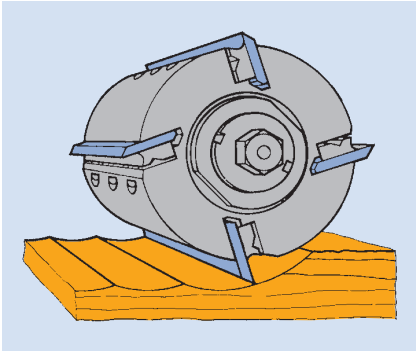

Finish formation for conventionally clamped tools

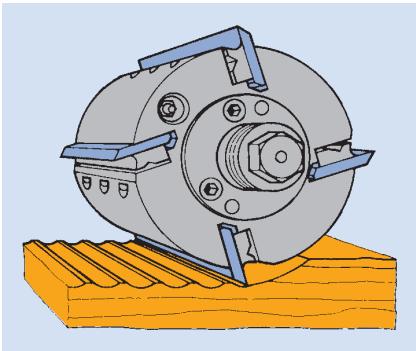

Finish formation for high precision tools with centering adaptor

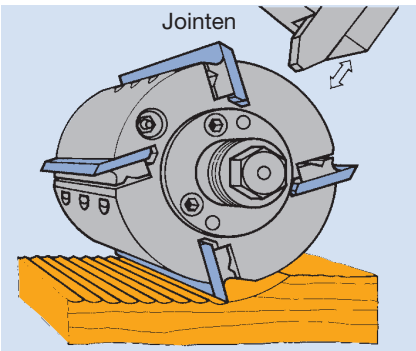

Finish formation for jointed tools with centering adaptor



Quality criteria „waviness“

The visible cutter marks on the workpiece $f_{z\text{eff}}$ correspond to a single knife finish ($Z = 1$). As the cutter mark pitch determines the quality of the workpiece's surface, the feed rate is equivalent to $Z = 1$ in these conditions.

$$\rightarrow f_{z\text{eff}} = v_f / (n \times 1) \times 1000 = f$$

(f = feed per tool revolution)

Multi knife finish

Tool concentric run-out tolerance is significantly reduced by a clamping system that centres the tool on the spindle, such as a hydro clamping system, shrink-fit clamping or HSK. Hydro clamping makes the cutting action of several cutters visible on the workpiece surface. The number and spacing of these is undefined (not regular) because of the remaining run-out tolerance. If the tool is carefully balanced (G 6.3 or better), an adequate finish can be obtained for many applications from this multi knife machining process if the feed rate is high, for example for tongue and groove panel processing or the production of linear mouldings.

A run-out tolerance of zero can be achieved by subsequently dressing the cutting edges within the μm range known as jointing which is performed at full operational speed on the machine spindle. The knife marks are then at uniform intervals on the workpiece surface. This technology enables the feed rate to be multiplied by the number of cutters, with the quality is equivalent to a single knife finish.

$$\rightarrow f_{z\text{eff}} = v_f / (n \times Z) \times 1000 = f_z$$

(f_z = feed per tool tooth)

Criteria for the processing quality

Tool parameters and tool life are measured by the processing quality. For judging surfaces, e.g. during planing, the distance and the depth of the visible cutting actions are decisive. Regarding coated panels, workpiece edges without break outs are important.

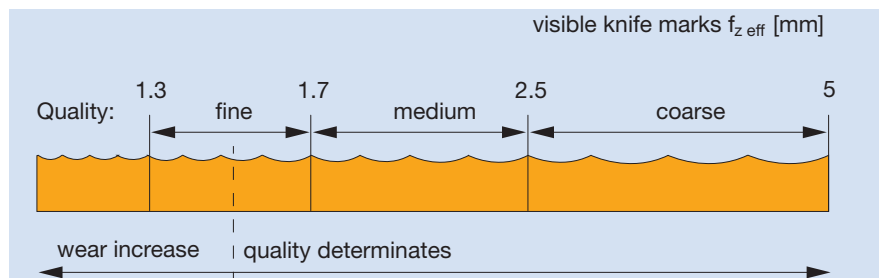

The cutting action of the highest protruding edge is responsible for the **distance of the visible cutting actions** (knife marks). The remaining blades produce chips; their start of the cutting angle does not reach the machined surface. Therefore, the jointing technique is in particular used for planing so that all edges process the planed surface to the same extent.

11.3 Fundamental cutting principles

11.3.4 Processing quality

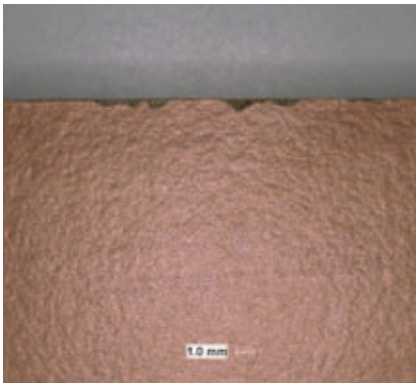

Quality criterion of „break outs“

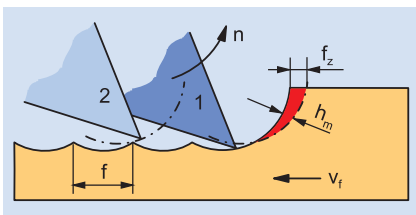

The tooth feed rate f_z defines the medium chip thickness h_m

$$f_z = \frac{V_f}{n \times Z}$$

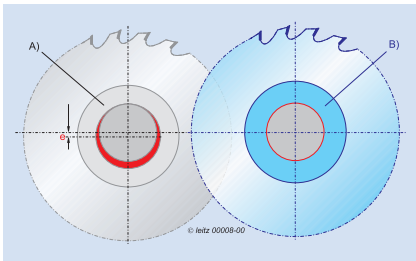

Centering tool interface

A) conventional interface with fitting tolerance „e“

B) Centering interface without fitting tolerance

Balancing quality: $G = e \cdot w$

The **depth of the start of the cutting angle** is determined by the tool diameter and by imbalances and vibrations.

For the quality criteria **tear outs or edge break outs**, the mean cutting thickness h_m is of particular importance. As the mean cutting thickness increases, the woodchips become more stable and tend to break and pre-split. A result is damage to the machined workpiece, that means tear outs or splinters in solid wood and edge break outs in panel materials. Therefore, tooth advance may not be increased arbitrarily. The possible tooth advance depends on the tool diameter and the start of the cutting angle of the tool cutting edges. There are specific guide values for the tooth advance f_z for each workpiece depending on the processing method such as sawing, cutting, planing, finish milling, drilling.

Imbalance and run out tolerances result in different mean cutting thicknesses on the cutting edges of a tool. The thickest woodchips limit the cutting performance. The better the concentric and the axial run-out of the tool cutting edges, the more even the mean cutting thickness of each edge and the higher the possible tooth advance f_z is. With a constant spindle speed n and tooth number Z , this means: Tools with a high imbalance and a small run-out tolerance allow for higher feed rates. At the same time, the higher feed speed is connected with enlargement of the start of the cutting angles with the side effect that further edges (even if with irregular distances) are involved in creating the surface finish. The law of the „single knife finish“ no longer applies.

Centred mounting sleeves such as a hydro clamping system, shrink-fit clamping or HSK eliminate the tolerance between the tool and the machine spindle and are required for low imbalance ($G 6.3 \text{ mm s}^{-1}$ or better) and for accurate concentric and axial run-out of the edges (0.02 mm or better). The tools must be sharpened mounted on this centred mounting sleeve.

If surfaces without tear outs and edges without break outs are a quality criteria and the processed surfaces are flat, then tools manufactured this way may be used for much higher feed speeds compared to a single knife finish. Examples for this include high toothed profile cutters for panel manufacture (laminated panels, tongue and groove boards) which are machined without jointing at feed speeds above 200 m min^{-1} or cutter tools for forming furniture panels which achieve speeds up to 100 m min^{-1} .

When choosing the appropriate machine tool, many interdependent factors must be considered. The goal to achieve a first-class wood surface finish, a saw cut surface without tear outs and an accurate drilling result requires that the cutting material, tool and machine operating data have been adapted to the material characteristics and to each other. Thus, the finished machine tool is the result of analysis and evaluations before the machine is built.

Determination of cutting speed in relation to speed of rotation and tool diameter

The graph shows the cutting speed in m s^{-1} in relation to the speed of rotation and tool diameter. The speed required can be determined if the tool diameter and cutting speed are known. Similarly, the tool diameter can be determined if the speed of rotation and cutting speed are given.

Reading examples:

	D mm	n min^{-1}	v_c m s^{-1}
Circular sawblades	350	6000	110
Cutting tools	160	9000	76
Shank router cutters	52	18000	50

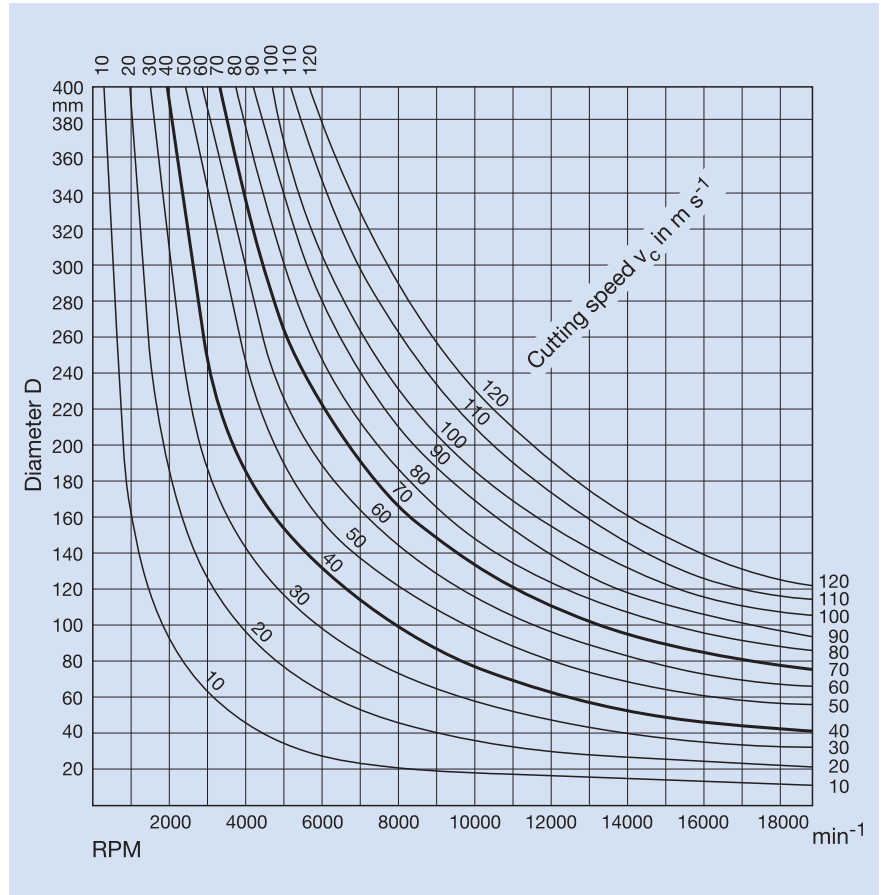

Cutting speed guide values v_c

Material	Cutting v_c [m s^{-1}]	Sawing v_c [m s^{-1}]
Softwoods	50-90	60-100
Hardwoods	50-80	60-100
Coreboards	60-90	60-100
Chipboards and fibreboards	60-90	60-90
MDF	60-90	60-90
Panel materials, coated	60-90	60-90
Thermoplastics	40-60	40-70
Thermosets	30-50	40-60
Aluminium	30-60	60-90

The guide values given here apply to tools with a diameter > 100 mm. Regarding shank tools, the recommended cutting speeds are considerably lower due to the small tool diameter and the higher friction (router cutter 10 to 40 m s^{-1} , drill 5 to 10 m s^{-1}).

Parameters for cutting tools
Tooth progression, feed rate, speed of rotation, number of teeth

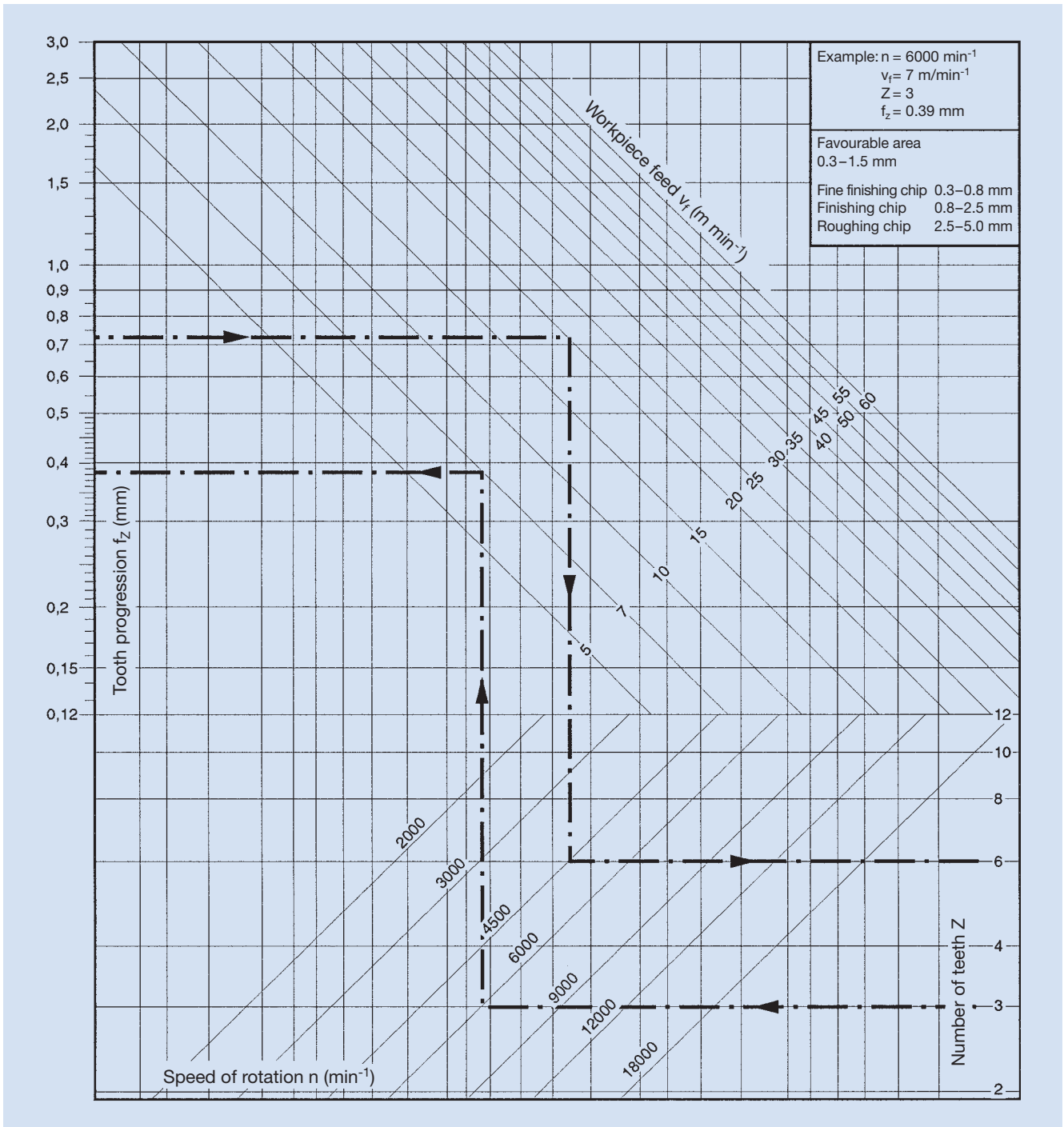

Parameters for circular sawblades
Tooth progression, feed rate, speed of rotation, number of teeth

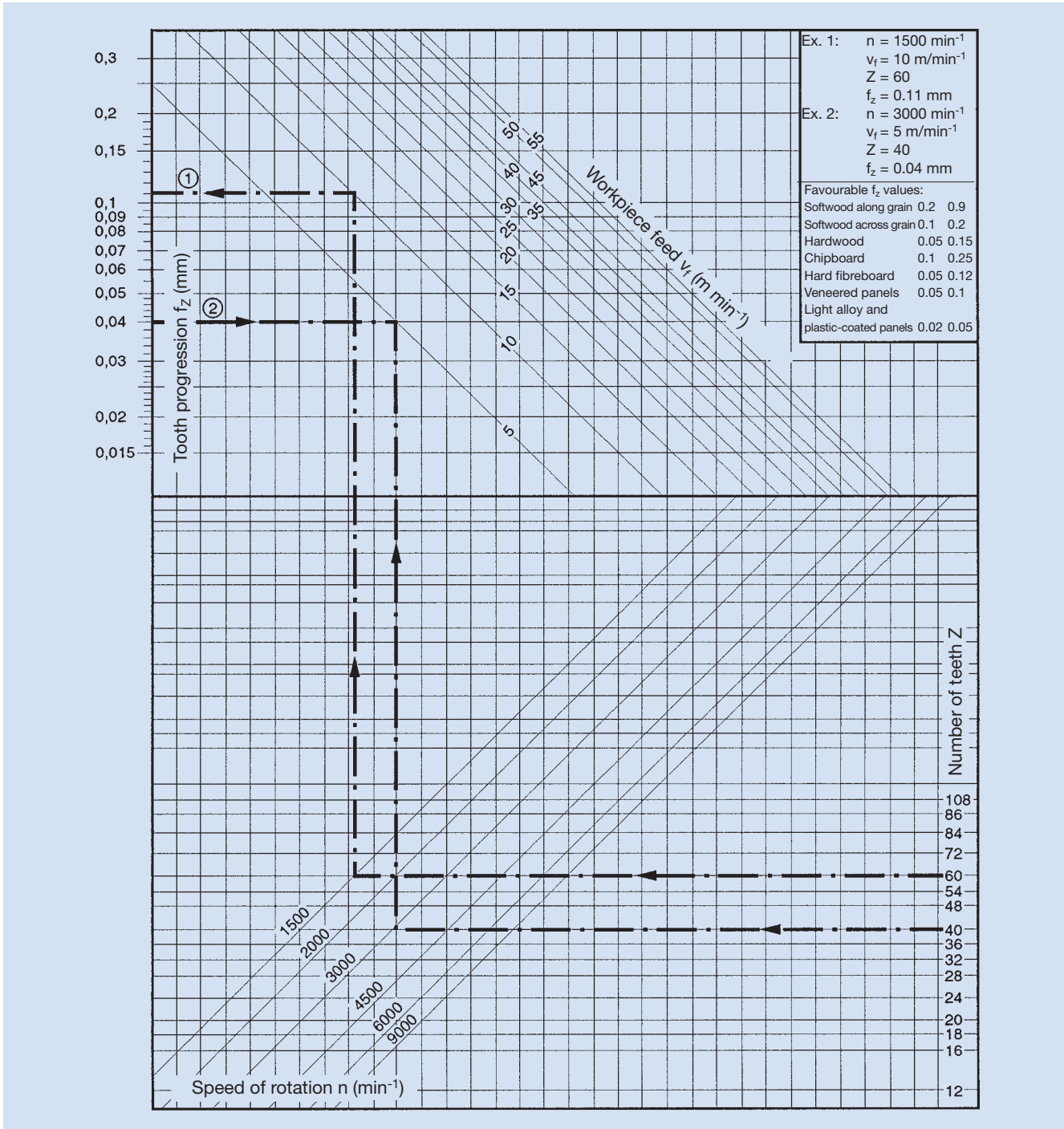



Solid tool
Example: HL profile cutter



Solid tool
Example: HW shank router cutter

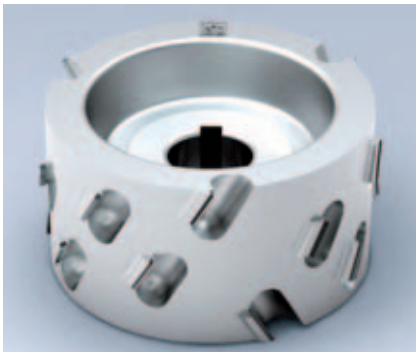

Tipped tool
Example: DP grooving cutter



Tipped tool
Example: HS minifinger cutter

Regarding tool types, the machine tools are distinguished by design and construction design.

Single part tools / solid tools

Solid tools are made from one piece. The basic body and the edges are of the same material. Typical examples of this tool type are profile cutters of HL steel, routers and drills of HS steel or solid tungsten carbide. All have been designed as resharpenable tools.

Profile cutters of HL steel are mainly used for profiling tongue and groove boards in the primary industries. They have a high number of teeth and a very large resharpening area so economical when it comes to high running performance. The one piece design allows for a high precision concentric and axial run-out which is why they can be used for feed speeds up to 200 m min^{-1} without jointing. A key feature of these cutters is the spiral relief in the profile. The free area of the edges is convex and follows a spiral form. The cutting edges are resharpened by turning the tools around its rotational axis. This ensures the wedge angle and cutting profile remain constant.

The reasons for a one piece design of routers and drills are different. Because of the small diameters, the most important factor is stiffness which is higher with a body made of HS steel or tungsten carbide compared to tempering steel. More efficient production is also very important.

Tipped tools / progression tools

Regarding composite tools, the edges and basic tool body are made of different materials. They are jointed to each other by brazing or adhesive. Typical examples of this tool type are circular sawblades with tungsten carbide or diamond tips and HS, HW or DP tipped cutters as well as HW tipped drills.

Brazing is at high temperatures between 650°C and 700°C . Due to the tensions occurring when the material is cooling down, the cutting material must have a particular toughness and may not exceed a certain thickness. An adhesive joint has the advantage that it can be done at lower temperatures. In doing so, the joint has less tensions so harder and more wear resistant materials can be used, in particular for tungsten carbide tools.

Tools tipped with HS or HW edges are mostly resharpened on the cutting face. Regarding circular sawblades and grooving cutters, it is recommended to also sharpen on the top surface (relation between face and top approximately 2:1) to maximise the use of the cutting material and to achieve longer tool life. As the free surface has a straight or convex relief, the profile changes slightly when sharpening the cutting face. Regarding glue joint profiles or finger joint profiles, both tools of a pair are always resharpened to the same extent to make sure the joint profiles match each other.

This is not the case with diamond tools. Here, the DP edges with the tungsten carbide support are brazed to the panel seatings so that the thin diamond layer forms the cutting surface.

11.4 Machine tools

11.4.1 Tool types

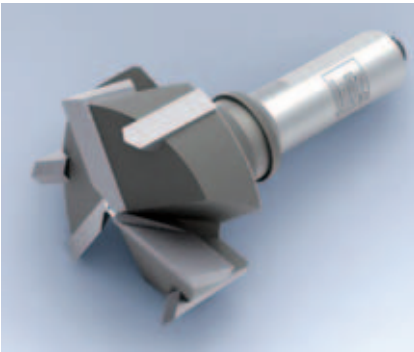

Tipped tool
Example: HW hinge boring bit



Turnblade tool for jointing and rebating



Profile cutterhead for backserrated blank knives

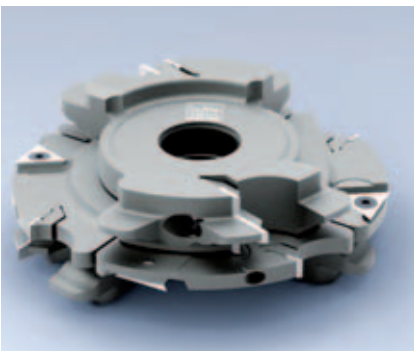

Profile cutterhead with throwaway knives and turnblade spurs

Resharpener may only be done on the top. As the edges always require a certain projection from the body of the tool, this must be adjusted during sharpening. When sharpening the top, the original profile may be kept. Only the cutting angle is increased.

Closed profiles with a steep run out angle must have a lateral free angle in addition to the radial free angle so that the tool does not „burn“. Such tools change their width when being sharpened. So, two piece tool designs are practicable to compensate for the change in profile width.

Cutterheads / assembled tools

Assembled tools are also known as cutterheads since the cutting edges are inserted as detachable knives. It is distinguished between turnblade knives or throwaway system where the knives cannot be resharpened, and resharpenable knife head systems. All cutting materials may be used. Knife head systems with tungsten carbide cutters are most common.

The advantage of knife head systems is that the tool body design can be reused and only worn knives must be replaced. Assembly and disassembly must be done carefully and under clean conditions to ensure accurate and safe positioning of the knives in the tool. The replacement of the knives is normally by the user, who is responsible for the accuracy and safety of his tools.

The simplest form of assembled tools are the turnblade tools. Standardised tungsten carbide knives with 2 to 4 cutting edges are used as cutters. When worn, they may be turned 1 to 3 times. The main cutters are normally straight turnblades. For edge processing of rebates or grooves, spur cutters are used and for profile edges, radius or bevelling knives are used. Typical applications are jointing, rebating and grooving tools, but also simple window tools. By separating the profile into many standardised individual blades not adapted to the respective processing situation in respect to their geometry, only a medium processing quality can be achieved, in particular on rounds and profile edges.

Tools with resharpenable knives are, for example, profile cutterheads with serrated back HS or HW knives. These can be resharpened more than 30 times in the profile, keep their profile and are very economical. Furthermore, such systems are very flexible as knives with different profiles can be mounted in one basic body. A disadvantage is the change in diameter so the position of the machine spindles must be adjusted after every sharpening.

Cutterhead systems with throwaway knives do not have this disadvantage. These are normally HW blades. After changing the knives, all tool dimensions stay the same. However, this advantage is gained at the cost of a high consumption of expensive tungsten carbide so such tool systems have high operational costs. In addition, the knife profile is related to the profile of the tool body design. So as is the case with tipped tools, every profile requires a complete tool.



Multi purpose cutterhead with backing plates „VariForm“

A compromise are universal profile cutterheads in which the cutting plates are not support by the tool body design, but by profileable and replaceable supporting plates (example: VariForm). Such systems may be resharpened 2 to 3 times on the cutting surface if a minor change to profile and diameter is acceptable.

Resharpenable tools

It doesn't matter if cutters or cutterhead systems, resharpenable tools use the expensive and valuable cutting materials in a more efficient way as throwaway tool systems.

For example a throwaway tool system with 2 mm tungsten carbide cutting edges waste 8 to 10 times more tungsten carbide material in tool life compared to a resharpenable tool system with a 5 mm tip height. But after every resharpening the dimensions of the tool are changing and a new set up at tools and machines is necessary.

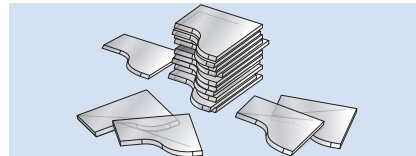

Throwaway tool System (2 mm)
Tungsten carbide consumption by 16 tool lives.

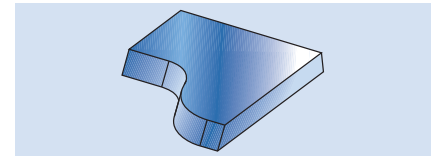

Resharpenable tool (5 mm)

Constant tools

Constant tools combine cost effectiveness of resharpenable systems with the handling advantages of throwaway systems. They are always designed as a cutterhead. A slot guides the knife position parallel to the clearance angle of the profile, so the knife always comes back to the same reference point after sharpening on the cutting face. This ensures that the profile and the diameter of the tool remain constant after sharpening. Adjustment of the spindle position is not required.

Examples for such self adjusting constant tools are the Leitz systems „ProFix“ for profile processing and „VariPlan“ for planing.



Constant diameter tool
Example: Planerhead „VariPlan“

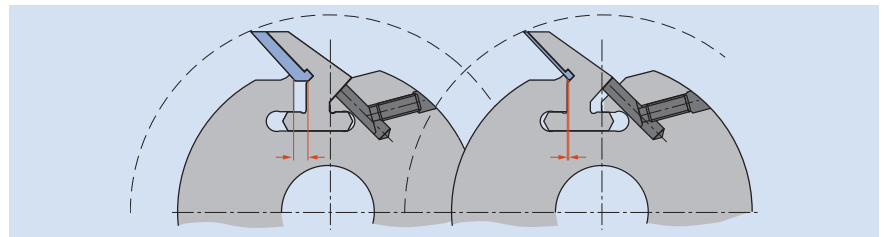

Functional principle: ProFix Constant diameter tool



Constant diameter tool
Example: Profile cutterhead „ProFix“

Another form of the constant tool are tools with adjustable knives. They are either adjusted to the diameter when installed (example: planing cutterhead with planer knives) or are moved to the extent of their wear before the sharpening process and then ground back to the nominal diameter (example: jointing cutterhead with cylindrical DP knife insertion).



Typical tooth shapes and applications

For special applications also sequences of various teeth can be used, combining several types of teeth (e.g. WZ/WZ/FZ). To protect the knife points against breakouts, all tooth shapes slightly can be bevelled (protecting bevel).

Circular sawblades

Circular sawblades for processing wood and plastics are progression tools. They consist of a saw plate with tungsten carbide or polycrystalline diamond teeth brazed to its circumference. They are used to separate workpieces. To keep the cutting loss and the cutting forces small, the aim is to keep the cutting width as small as possible. On the other hand, straight cuts free from scores require a certain blade stability; this invariably means a compromise between cutting width and saw diameter.

Depending on the material and geometry of the workpiece, the saw teeth differ in shape and geometry. Generally, positive cutting angles are used to keep the cutting forces low. For thin walled workpieces such as e.g. hollow profiles, negative cutting angles are required to prevent the saw from catching. The number of teeth depends on the requirements for cut quality. The rule of thumb is: the higher the number of teeth, the better the cut quality to be expected, and the lower the number of teeth, the smoother the saw cut.

Classification of typical teeth forms and applications:

	Tooth shape	Application
	Flat FZ	Solid wood, along and across grain.
	Alternate, positive WZ	Solid wood along and across grain as well as glued, wood products uncoated, plastic coated or veneered, plywood, multiplex, composite materials, laminated material.
	Alternate, negative WZ	Solid wood across grain, hollow plastic profiles, non-ferrous metal extruded profiles and tubes.
	Square/trapezoidal, positive FZ/TR	Wood products, uncoated, plastic coated or veneered, non-ferrous metal extruded profiles and tubes, non-ferrous metals, Al-PU sandwich panels, hollow plastic profiles, polymer plastics (Corian, Varicor etc.)
	Square/trapezoidal, negative FZ/TR	Non-ferrous metal extruded profiles and pipes, hollow plastic profiles, Al-PU sandwich panels.
	Inverted V/hollow ground HZ/DZ	Wood products, plastic-coated and veneered, coated profile strips (skirting boards).
	Flat, bevelled ES	Construction industry machine saws.

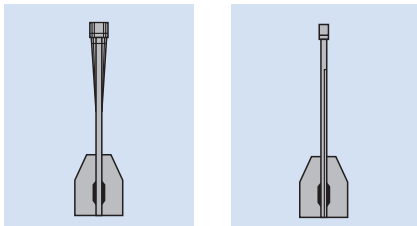
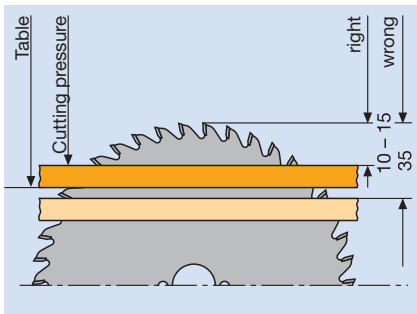

Sawblade without damping

„Foil saw“ with good noise- and vibration damping



Thin kerf sawblade set to produce parquetry laminates

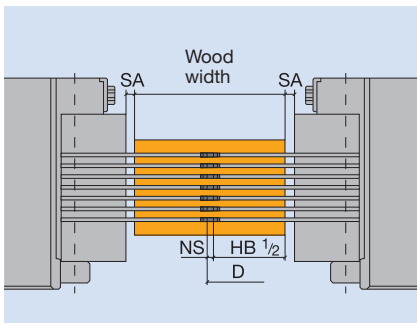

Inherent to the functional principle, the cutting edges on the tooth entry side are a better quality than the ones at the tooth exit side. By setting the projection of the teeth above the workpiece it is possible to influence the cut quality in certain areas. The point of reference here is a value of 10 to 15 mm.

With a greater projection of the teeth, the quality at the exit side suffers, with a smaller projection quality at the entry side suffers. To achieve a cut edge without tear outs on both sides it is required to use scoring saws at the exit side of the main saw. These are sawblades with a small diameter but a greater cutting width than the main saw by 0.1 to 0.2 mm, scoring the workpieces with feed to a depth of 1 to 2 mm. To adjust the cutting width to that of the main sawblade, scoring saws are designed either in two parts or with a tapered tooth shape. Special concave tooth saws have been developed for panel saws without scoring saws; these saws enable cuts without tear outs to both sides when set correctly but have a comparatively short tool life.

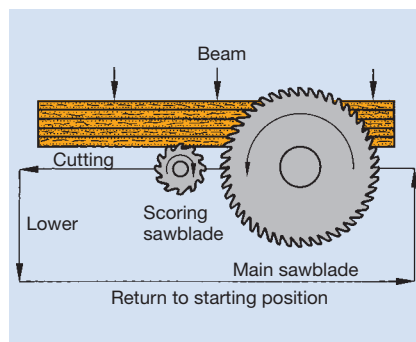

Panel sizing machine with scoring unit and pressure equipment

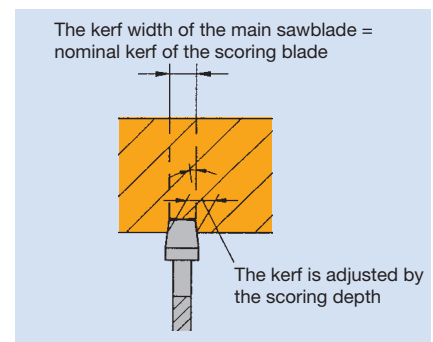

Application scheme of a conical scoring sawblade. Servicing the tools (always in sets), the cutting widths have to be machted to each other.

A basic prerequisite to achieve cut surfaces without scoring is a good axial saw run-out but also low vibration. For this, the sawblades are pre tensioned by roll rings so they run stead even when subject to centrifugal forces. Additionally inserted laser ornaments and applied films absorb vibration and at the same time reduce noise. The biggest effect is achieved with foil laminated saws. The noise reduction here is up to 10 dB(A), a noise reduction of half.

Special thin cut saws were developed for separating high quality wood, e.g. when manufacturing parqueting blocks. Depending on the diameter, the cutting width is within a range of 1.0 mm to 1.6 mm. The teeth protude little laterally compared to the saw plate. Their application makes special demands on the woods' drying and the workpiece guidance in the machine, in particular the separated segments.

Ideally, circular sawblades should be sharpened on face and top to maximize tool life. For this reason the saw plate must be relieved at the back. As the teeth becoming smaller, the cutting quality improves since the protrusion of the teeth becomes smaller and the tooth vibrates less. However, the gullet also becomes smaller which is why the feed speed must be adjusted.

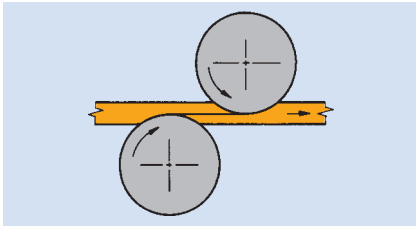

Double-hogging

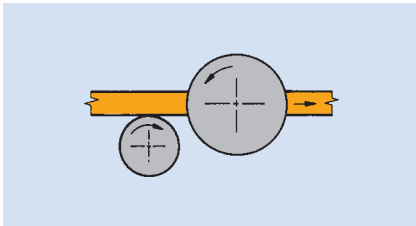

Scoring/hogging



Compact hogger
Example: Diamaster DT



Sawblade hogger

In many countries circular sawblades are resharpened only at the face due to sharpening machine limitations. To remove the wear zone, a significantly more sharpening than when sharpening on face and top is required. So, the sawblade may not be resharpened as often.

Hoggers

Hogger means tools that are processing the narrow sides of panel materials with their frontal cutting edges. They are face plain cutters and are used to format panels in through feed machines. To achieve cutting edges without tears you need two tools. There are two different types: „double hogging“ and „scoring/hogging“.

In case of „**double hogging**“ a tool cuts with the feed both at the top and bottom of the panel, overlapping in the panel centre. Both tools are aligned accurately at one level and produce a smooth cutting area which may be edged later.

In case of „**scoring/hogging**“ the underside of the panel is scored 1 to 2 mm deep (depending on the decorative coating's thickness) by a scoring hogger with feed and subsequently finished by a hogger from the top against the feed. To avoid edges tearing at the hogger's blades exiting the wood, the hogger is angled by 0.1 to 0.2 mm axially so that a small step appears on the cutting surface.

In addition to processing narrow edges, the hoggers also have to completely hog the material overhang. For this, the circumference must have a certain hogging width, between 5 to 10 mm for most applications. Regarding the tool design, a distinction is made between „compact hoggers“ and „saw hoggers“. In case of compact hoggers all edges are mounted on a basic tool body. Usually diamond tipped tools. In case of saw hoggers a sawblade is screwed to the basic body process the narrow edge while flange-mounted cutters or saw segments hog the remaining material overhang. Usually diamond cutters are used for the sawblade while in most cases tungsten carbide knives are sufficient remove the material overhang.



Depending on the type of decorative coating, a distinction is made between different profile types of the hogger knives, such as e.g. radius or bevel knives or knives with a one sided tip. In recent years, a step profile has been developed (e.g. Leitz Diameter DT), significantly lowering the risk of damage to the knife from foreign matter in the chipboard. There are special shredder knives for processing veneered boards, breaking up the free veneer overhang so that the extraction is not blocked by veneer strips.



Cutter spindle „CentroStar“

Cutter spindles

Cutter spindles are tools permanently installed in the machine. They are found mainly in thickening and planing machines. They are composite tools with knife replacement always in the machine to reduce down time and ease work on the machine, centrifugal force clamping systems automatically clamp and position the knives when the spindle is run up (e.g. Leitz CentroFix).

Spiral cutter spindles with smooth knives have proven to be particularly quiet. However, such technique can only be used for HS steel knives and not tungsten carbide.

Planing tools

Planing tools are peripheral cutting tools with continuous straight knives. Usually they are designed as planerheads. They are used for smooth surfaces, primarily in processing solid wood. HL, HS and tungsten carbide knives are used as cutting material. The number of blades is between $Z = 2$ and $Z = 36$. The cutting width ranges up to a few hundred millimeters. For precutting, planing tools with segmented edges (HeliPlan) or with ripple profile (**VariPlanPlus/RipTec**) are advantageous. They reduce the presplitting and prevent the wood from an early damage, so that considerably more even surfaces are produced during the enclosed finish planing.

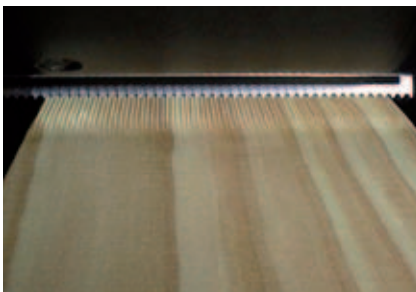

RipTec - preplaning tool



Finish planed surface after conventional preplaning.



Finish planed surface after preplaning with RipTec.

Conventional planerheads have two or four knives and are connected to the machine spindle via a drilling fit. Due to tolerance one knife is decisive for the surface. The feed rates achieved range from 9 to 36 m min^{-1} , depending on RPM. and required surface quality. Planerheads for higher feed rates have a hydraulic clamping or a HSK interface to guarantee a centering of the tool with the machine spindle free of play. For the hydraulic clamping grease-filled chambers in the wall of the tool are pressurized by a grease gun. By expanding the tool chambers, the bore shrinks, and the tool is locked on the spindle. In case of the HSK interface the centring is made by a positive taper lock axially pulled and positioned against a locating face.



Preplaning tool „HeliPlan“ with HSK

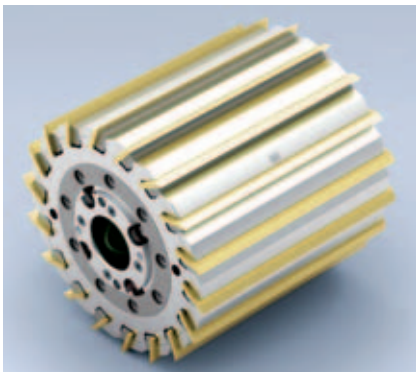

High performance planerhead „TurboPlan“

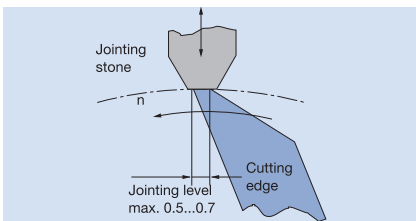

Jointing of a planerhead

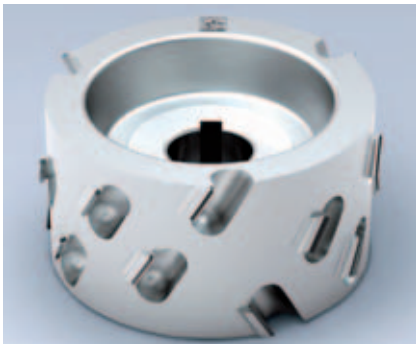

DP jointing cutter

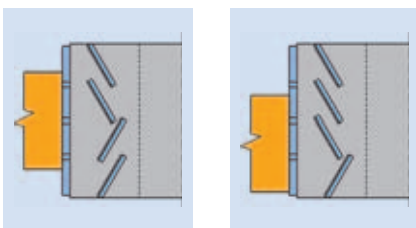

Symmetrical/asymmetrical edge arrangement

By centring a high balancing quality and best possible true knife running is achieved by truing the knives in the machine, „**jointing**“. After jointing, all knives have the same cutting circle and are equally responsible for the surface finish. Feed rates of over 400 m/min are possible.

There are other differences in the way of knife clamping. It is becoming more common for conventional planerheads to use cutting edge systems (e.g. CentroStar or VariPlan) enabling a swift replacement of knives with minimum setup, the hydro planerheads predominantly use systems with planing knives that can be adjusted and resharpened, (e.g. Leitz RotaPlan). There are also tool systems that drastically reduce the high setup effort when replacing the knives. Those include, among others, the Leitz system „TurboPlan“ in which all knives are positioned by a positive fit and are clamped simultaneously by hydraulic clamping.

Jointing, grooving and rebating tools

Like planing tools, **jointing tools** cut on the periphery; however, the cutting width is significantly smaller and usually under 100 mm. Jointing tools are designed as turnblade tools or milling tools and are used predominantly in panel processing. The cutting material ranges from tungsten carbide to polycrystalline diamond for industrial use. To protect the edges of the workpiece from tear outs during processing, the knives have shear angles for an angled cut usually the surface. There are **symmetrical and asymmetrical tool designs**. Asymmetrical means that the lower knife row is aligned upwards and all knife rows above it are aligned downwards. These tools are set up with the lower row of knives aligned with the bottom of the workpiece and can process variable workpiece thicknesses within their cutting width in this position. If the angles of the knife rows are aligned symmetrically to the tool's midplane, the tool must always be aligned with the workpiece centre. When changing the thickness of a workpiece, the tool position must also be adjusted. The advantage of the symmetrical design is that the jointing knives have a slightly convex design and thereby generate a defined concave cut of a few hundredth millimetres on the workpiece. This guarantees a tight glued joint on edge banding machines.

In addition to the peripheral knives, **grooving and rebating tools** have lateral knives, e.g. spurs, or the knives' sides have a clearance angle. On both sides for grooving tools, on one side for rebating tools. For grooving tools, there are two different types: one part tools (similar to circular sawblades) and two-part adjustable tools for variable groove widths and for correcting the cutting width after sharpening.

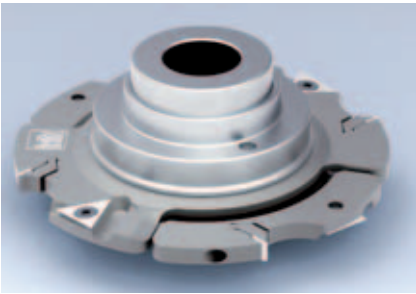

Grooving cutterhead, width adjustable



Multi purpose cutterhead „VariForm“



Multi-part ProFix tool set for window profiles



Panel raising tool

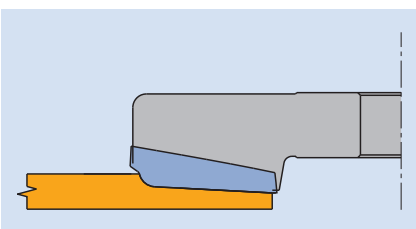

Profile tool systems

Profiles range from simple profiles like bevels or radii to decorative profiles to highly complex jointing profiles, such as finger jointing, slot and tenon or counter profiles. Its application is a common across wood processing field. The range of cutting materials is extensive, from HL steel to polycrystalline diamond (DP). The tool types range from solid cutters to brazed tools and profile cutterheads to constant profile tools that can be resharpened.

Multi purpose cutterheads play a special role. Knives moulded in any way may be inserted in a tool body. The blanks may be profiled by a sharpening service or by the user, enabling a quick production of the required plus low tool costs for small production volumes.

For profiles, a distinction must be made between one-sided or open profiles and closed profiles with radial profile shoulders on both sides. While one clearance angle on the profile is sufficient for one-sided or open profiles, the knives must have two clearance angles on the sides for closed profiles. This has consequences in the tool design: such profile cutters must be designed in two parts so that profile changes resulting from resharpening can be compensated. However, turnblade tools that are not resharpened can be designed in one part.

To enable great profile depth it is of advantage to assemble tool sets from several different individual tools of varying diameter. Hence you can use smaller discs and achieve higher speeds. Additionally, the cut distribution can be better adjusted to the workpiece and profile. A classic example is window tools.

Panel raising tools are a special form of profile tools with profile knives arranged on the face of the tool. They are used to profile the infill panel for doors. Due to the small setting angle κ , they produce a surface almost without any plane knocks.

Shank tools

Principle, these are the same tool types as for jointing, folding, bevelling, panel raising and profiling cutters but with shank as for drills; they only have a smaller diameter and can be used for higher speeds.

The **routers** are a special case. Usually they have a high **slenderness ratio**, e.g. they are much longer than they are wide. They are mounted in a chuck by their shaft, and the cutting part is outside the chuck. So, the tool is subject to a high bending stress and the breakage due to overstress is high. This is the reason why the **cutter marks f_z** are also significantly smaller than for drilling tools. They are less oriented towards hogging relevant values such as the mean cutting depth h_m but towards the tool's load capacity. This depends on the unsupported length and diameter. This is why, for example, the admissible feed rates for splitting or grooving are usually lower than for jointing.



Spiral finishing router in solid tungsten carbide

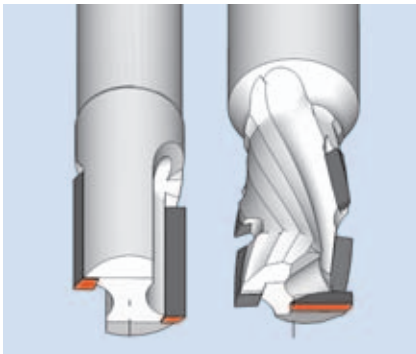

DP router
left: cutting in end grain
right: plunging tip

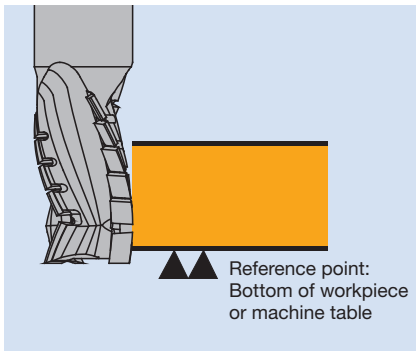

DP-shank cutter with mainly negative twist

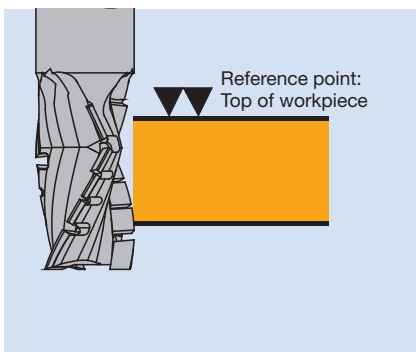

DP-shank cutter with mainly positive twist

Important design features for routers are the design of the knives and the helix or shear angle. The tool is suitable for axial drilling when it has a basic knife extending to the central axis and if it is designed with a positive helix angle. **Axial drilling** should only be the exception for quality and tool stationary time reasons. It is more gentle for the tool to enter the material by **helical drilling or ramping in** at angle. In such case the requirement for the tool is only a knife front clearance angle, usually the case for routers.

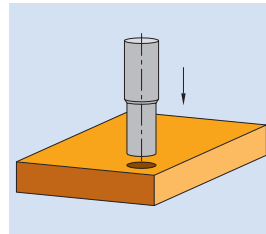

Axial plunging

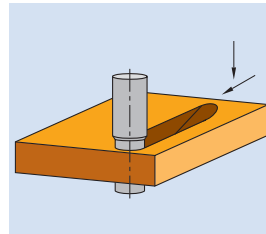

Plunging

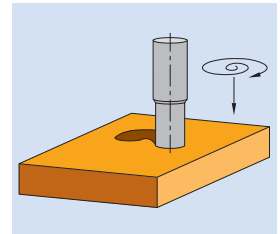

Spiral shaped plunging

The **helical angle** plays another role. An upward positive helical angle favours swarf removal towards the extraction hood and prevents tears on the lower cutting edge (workpiece side at the bottom). A downward negative helical angle applies pressure to the workpiece, supports the workpiece and prevents the upper cutting edge from tearing (workpiece side on top). Routers used for sizing coated panels material have both negative twist in the upper knife and positive twist in the lower area. Hence, top and bottom of the panels are processed without any tear outs. If the proportion with negative twist prevails, the tool can process varying panel thicknesses with the same length set up. If the proportion with positive twist prevails, the dust collection is improved significantly; however, the tool must be adjusted to the relevant board thickness in its axial position.

It is normal for routers that their milling part may be programmed at will. If this results in unfavourable machining situations such as cutting contrary to the fibre direction or exiting the workpiece against the feed, the turning direction must be changed. For this reason most routers have **left hand rotation** in addition to the usual **right hand rotation**.

Tungsten carbide (HW) in solid, tipped, or turnblade or **polycrystalline diamond (DP)** are used as cutting materials. Tungsten carbide tools can be produced with continuous knives and are suited to solid wood processing as finishing tools. Diamond tipped routers always have segmented knives and are mostly used for coated chipboard and fibre materials. It may be that turnblade routers are inferior to solid or tipped tools regarding their feed rates but, their use is justified in cases when constant diameters are important or where it is not possible to sharpen the tools.

For fast roughing (hogging) routers have a **roughing profile**; a wavy profile that is slightly set off at each knife breaks up the chip, and the cutting force is reduced allowing higher speed rates. Special designs with a cascaded profile, the individual steps in total create a straight line, allow hogging processing almost to finish quality. This is the roughing finishing router.



Turnblade shank router

In the aim for more flexible manufacturing with smaller batch sizes, separating boards with router cutters (example: Nesting) is competing against circular saws more and more. Nesting requires small tool diameters of 10 to 12 mm and high feed rates of 20 to 30 m min⁻¹. This makes high demands on the tool stiffness and why tungsten carbide tools are used predominately for **Nesting**.

Resharpening of tungsten carbide routers is usually on the cutting face, however, for diamond-tipped routers it is at the edge.

Drills

In principle, drills differ from routers as the knives are only at the end; the periphery is ground circular. They only produce holes with a fixed given diameter. The feed movement is axial.



Roughing-finishing router of solid tungsten carbide

A distinction is made between drills for through holes, e.g. for screws, and those for blind holes, e.g. for plugs or fittings. Through hole drills have a slim tip to produce entrance exits without tear outs by its scalloped cut. Typical features of drills for blind holes (e.g. plugs or for fittings) are spurs to avoid tear outs at the drilled edge when penetrating the panel, flutes to produce a smooth side, and a centring tip so that the drill is centred when drilling. Ideally, the spurs are formed in a way to apply pressure to the workpiece surface when penetrating and create a pulling cut. Both wood fibres and decorative coatings are cut cleanly before the flutes clear the inside of the drilled hole. Usually the diameter of the flute is reduced by a few decimillimeter right behind the drill tip to reduce friction between drill and drill hole and to help chip removal.



Through hole boring bit

Essentially, drills for solid wood and board material differ with regard to cutting material, helical angle and length. Solid wood drills are manufactured from HS steel or tungsten carbide while it is mainly tungsten carbide and occasionally polycrystalline diamond that is used in drills for panel processing. Since the helical angle is the cutting angle for the drill separating the wood fibre requires a „destructive” cutting edge, solid wood drills have higher helical angles than drills for panel material. The required drilling depths are greater for solid wood applications than for panel material, and the drills are longer. For very deep holes, single edged „Levin drills” are used because their gullet aids chip removal. To avoid the chip choking and creating high frictional heat it may be necessary to clear the cutting space by withdrawing the drill for a short time.



Dowel drill

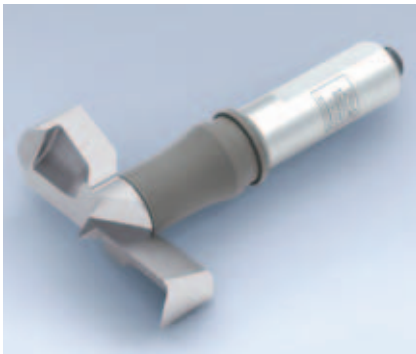

Hinge boring bit



Levin drill



Multi purpose profile cutterhead for manual feed with limitors

When using drills in drilling units and drilling aggregates, a constant length is important so the drilling depth always remains unchanged. Drills have a screw for adjusting the length at the end of the shank to set the drill length in advance so new and resharpened drills always have the same length. Most drill aggregates have different spindle rotations for design reasons. That is why there are drills rotating left hand and right hand. To reduce the danger of confusion, the two rotations are marked with different colours; drills rotating left hand usually are marked with a red colour, right hand black.

Cutting tools for manual feed

Cutting tools for manual feed must be designed with kickback limitation. They are subject to limitations regarding number of teeth, knife protrusion and gullet. The tool body must either be circular or equipped with limiters restricting the knife protrusion and the cutting gap width.

The design details vary with type of tool and are regulated in the European standard EN 847-1 „Machine-tools for the woodworking industry safety demands”. Cutting tools authorised for manual feed are marked „MAN” on the tool.



Arbor with detachable spindle/hub connection

Tool clamping systems are the interface between tool and machine. They have an adaptor on the tool side and a mounting sleeve on the machine side. The tasks of the tool clamping system falls under three heading categories:

- **Torque transmission**
The cutting forces must be received with sufficient safety, the tool must not spin.
- **Centring**
The better a tool is centred on the machine spindle, the better the concentricity and balance quality.
- **Replacing tools**
The tooling times are shortened by easy and fast tool replacement. Automated tool replacement is required for flexible production.

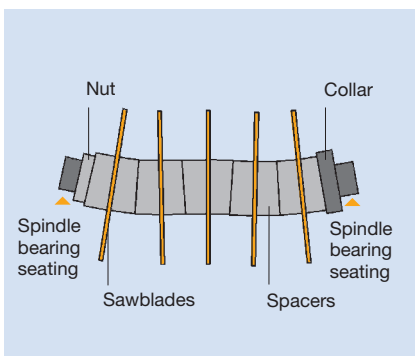

Tools on a spindle axially clamped against each other

The simplest form of tool clamping is a shank/hub connection. The tool is centred by means of a defined clearance **fit between tool bore and machine spindle**. Positive fit elements such as feather keys or drive pins transmit the torque. They are clamped by nuts at the shank end. Examples are drilling tools or flanged bushes for motor spindles with splined shank or cylindrical spindles of planing and finger jointing machines. This type of tool clamping has two important disadvantages:

1. The tools are not centred free of play. The centre of gravity is offset by the tolerance, with a negative effect on concentricity and balance quality.
2. If several tools are clamped side by side or on top of each other, the axial run out tolerance of the bodies increases. If the body faces are not parallel. When applying axial tension at the end of the shank, the spindle may bend resulting in an increased imbalance and loading to the bearings.

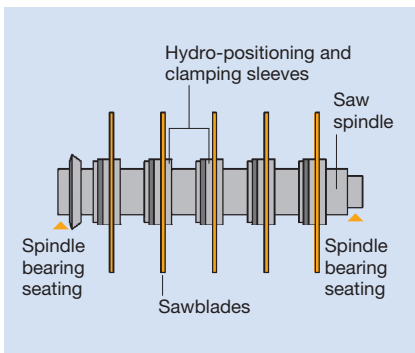

Hydraulically clamped tools on a spindle not depending on each other

Tool clamping systems that centering free of play were developed to eliminate such disadvantages. One example is **hydro tools** or **hydro clamping elements**. This clamping method consists of a ring chamber around the bore filled with grease or oil. When pressure rises in the chamber, the thin wall concentrically distorts towards the bore. The tolerance becomes zero, and the tool is clamped to the shank. The tools are clamped individually to the shank, there are no clamping forces, and the shank is not bent. Open and closed systems are defined by how the pressure is introduced.

Open systems are filled with grease. The pressure is increased by means of a grease gun. To release the pressure, grease is let out by a bleed screw. Such systems usually can be found in the moulding, planing heads and profile tools. The required pressure of approximately 300 bar is adjusted by the volume of grease pressurised. The system can be used in a wide range of temperatures, important for planing mills.

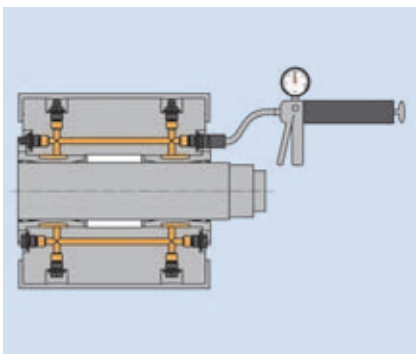

Hydro clamping technology, open system

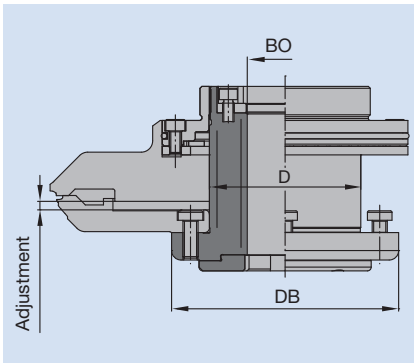

Hydro-Duo clamping element with two independent chambers for adjustable tool sets

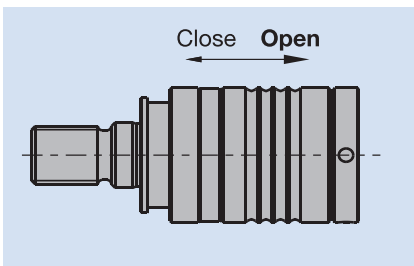

Drill quick clamping system



Tool set with HSK adaptor for automatic tool change

Closed systems are filled with grease or oil. Pressure is built up and released by an internal piston. The pressure is limited by the piston displacement and varies with temperature. Such systems are preferred where workpiece cleanliness is essential, e.g. in furniture, window or floor manufacturing.

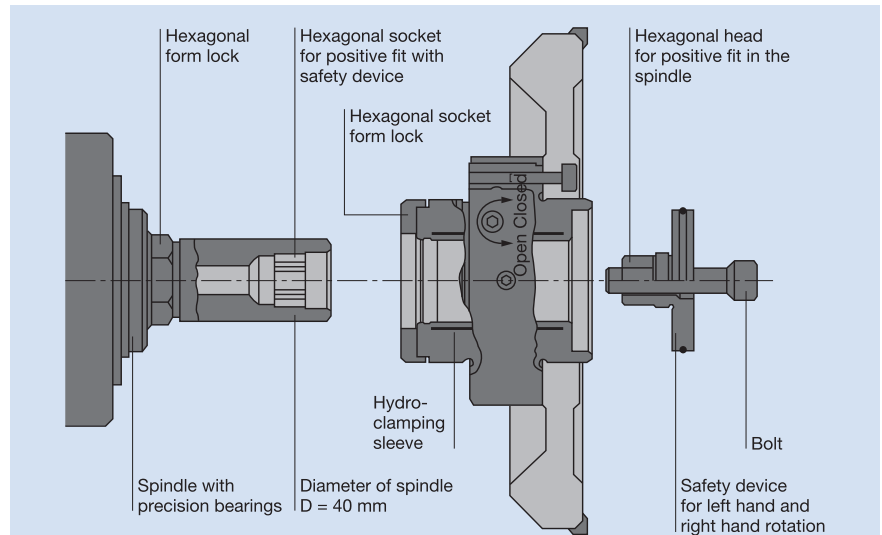

Hydro-clamping element, closed system

Hydro clamping elements usually are designed as „**Hydro-Duo clamping elements**” with bi-directionally to center the tool on the clamping element and the clamping element on the shank. Such Hydro-Duo clamping elements are ideal for adjustable two-part slot and tenon tools. When the pressure is released in the outer chamber, a tool part may be moved axially. During the subsequent build up of pressure the tool is centered and clamped again in its new position

As a safety measure against losing pressure, hydro clamping systems additionally are secured mechanically by locking mechanical collars as safety devices against twisting.

To shorten the tooling times for replacing the tools, **quick change systems** were developed for mounting on the machine shank and have a mounting tool flange clamped and loosened in seconds. Examples for this are bayonet mount systems for drilling tools that are operated mechanically or pneumatically or quick change systems that are operated totally tool free, similar to a hose coupling. Despite significantly reduced tooling down time these systems still require a manual intervention in the processing procedure.

Taper mounting sleeves between tool and machine were developed for **automated tool replacement**. Initially they were quick release tapers such as SK 40 or SK 30 but today **HSK interfaces** have expanded globally in wood processing. While initially developed for CNC processing centres, they have arrived in the through feed machine sector, in double end tenoners or planing/profiling machines. The HSK interface incorporates the advantages of both hydro and quick connect clamping systems: precision and speed.



Hydro-strain clamping chuck



Collet chuck



Shrink-fit chuck ThermoGrip®

Ideally the HSK is designed in one part with the tool. So, the tool diameters can be reduced and speed can be increased. However, in most cases it is not possible for structural or economic reasons. This is why there are HSK adapters that are screwed to the tool. Hydro clamping systems are used again, for a removable and tool centring connection. A distinction is made between hydraulic chucks for drilling tools or multi-part tool sets in which the clamping mandrel is hydraulically opened out, and **hydro clamping chucks** for clamping shank tools.

Collet chucks are a universal clamping system for shank tools. By using exchangeable collets, any shank diameter up to 25 mm may be clamped. The multitude of parts and wear on the collet result in moderate values of concentricity and balance quality. Tool excentricity may be up to 0.06 mm. High spindle speeds result in the nut being opened with a loss of clamping force. Consequently, high-quality collet chucks have balanced clamping nuts with an internal ball bearing to produce a higher preliminary tension. On the machine side, the collet chucks are designed with a HSK or taper interface.

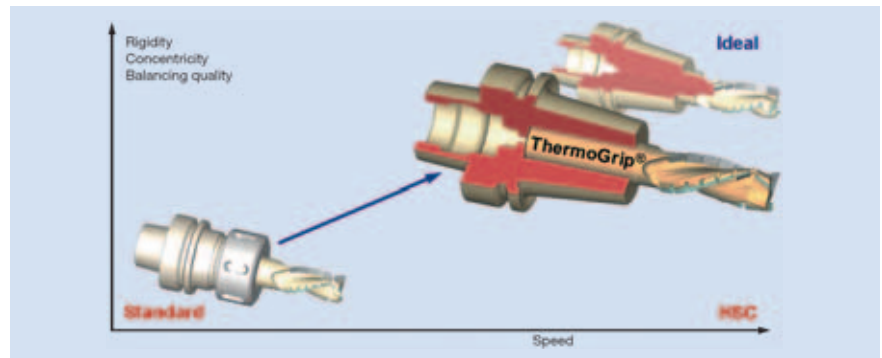

Shrink-fit chucks „ThermoGrip®“ were developed for high performance processing. They create a virtual monolithic connection between tool and chuck. The chuck principle is based on thermal expansion and functions without mechanically moved parts. To insert the tool shank, the clamping part of the chuck is heated. The chuck bore is manufactured undersize expands, receives the tool shank and shrinks while cooling. This way, tool and chuck are connected to each other as one piece. The chuck is heated by induction by special high frequency generators. The chuck’s heat expansion is faster than that of the tool so that the tools may be shrunk out again. Shrinking chucks „ThermoGrip®“ may be used at speeds up to $n = 36,000 \text{ min}^{-1}$, and due to their stiffness enable 30 % higher feed rates compared to collet chucks even in the conventional speed range up to $n = 24,000 \text{ min}^{-1}$.

The same technique of shrinking on tools is also used for arbors for tool sets. It makes sense if the tool remains on the arbor for sharpening or changing knives. A higher balancing quality is achieved by the shrink fit connection since tools and arbor can be balanced as a unit, and the tool weight may be reduced by using light alloy tools. Both result in a considerable increase in the feed speed which increases productivity on stand alone machines, for example in window manufacturing with the wide tool sets usual in this industry.

Highest precision regarding concentric and axial run out and balancing quality is achieved if the tool is sharpened with the clamping system as a unit. This requires universal tool interfaces on the wood processing machines in production and the tool sharpening machines in service. Tools conditioned in this way may be operated at higher feed speeds and have a longer tool life.

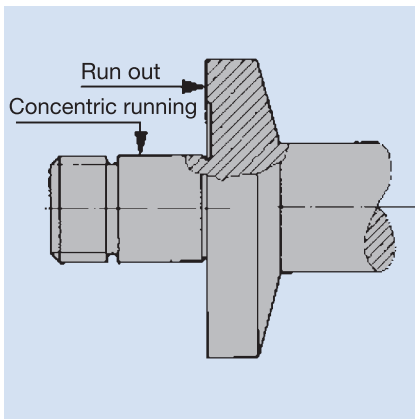

Concentricity and run out

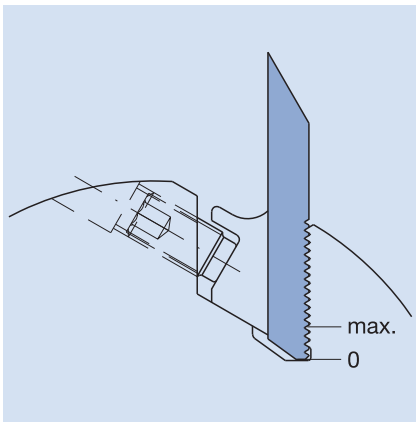

Note the readjustment area

1. Measures before commissioning

When installing a tool on the machine, please check the following points:

- a) **Please read the instructions before commissioning the tool.**
- b) **Clean the tool and the tool adaptor.**
All mating surfaces, the knife seating, the interfaces between machine spindle and tool adaptor, must be free from dirt, grease and corrosion.
- c) **Clamp tools only between the intended clamping areas in the machine.** Clamping areas, such as bore, boss, conical surfaces and knife seatings must not be damaged during assembly.
- d) **The blades must not come into contact with machine parts during assembly – risk of breakage!**
- e) **Check tools for chipped or damaged blades** – in particular if the tool has collided with machine parts, such as machine table, tool clamping elements, extraction hoods. Do not use tools that have been deformed. Have damaged tools checked by an expert. Sets containing damaged or worn cutting edges, clamping elements or screws must be replaced with original parts. Tools with a damaged tool body or deformed knife seating must be removed. Repair of such tools is forbidden!
- f) **When assembling tool sets, use face ground spacers.**
- g) **Tighten all clamping screws with the correct key.** The torque specified in the operating instructions must be observed. Using of extensions or hammers not permitted.
- h) **Check tool tension and feed rate.**
- i) **Check the correct direction of rotation of the tool.**
- j) **Compare the maximum rotational speed (n_{max}) of the tool with the rotational speed of the machine.** The value (n_{max}) as stated on the tool must not be exceeded. The rotational speed ideal for the application may be below n_{max} .

2. Measures to be adopted/care during use

Special care is required to maintain the quality and precision of a tool throughout its life. The following points are important for professional handling of the tools:

- a) To prevent corrosion, protect wood processing tools from humidity. If not in use for a long period, the tools should be treated with a suitable care product, such as WD-40 or Ballistol.
- b) Protect cutting edges and clamping surfaces from damage. For example, store and transport the tools in their packaging and do not place them on hard surfaces.

Tool wear and cutter condition should be checked during use to confirm the tool is serviceable, and to avoid unnecessary expense. Do not in any circumstances wait until cutter wear (blunting) has become too great or sections of the cutting edge have broken away. On many machines, checking the power consumption with an ammeter is an easy way to monitor the condition of the tool.

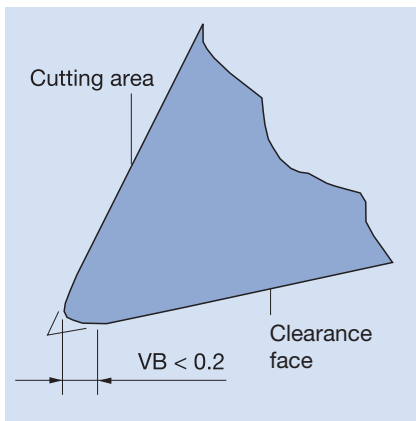

Maximum width of wear mark VB.

Cutting generates dust particles which, when mixed with resin or adhesive, can build up on the cutters or in the tool gullets. Such build up reduces the cutting angle, the size of the gullets, increases the power requirement, it shortens the tool life, reduces the surface quality and can, in extreme cases, even burn out motors.

Cleaning tools is not a luxury but an essential part of their use. Tools should be regularly cleaned of resin; special commercial cleaning agents are available. For tools with aluminium bodies, use only commercial cleaning agents with a pH value of between 4.5 and 8, as corrosion can destroy the alloy. Attention: Always comply with the manufacturer's instructions.

Frequent removal of any resin build up is especially important with tungsten carbide sawblades, as even small cutter projections have this problem. In some cases resin build up can lead to cracks in the sawblades.

Particles of workpiece material can damage the cutters if dust and chips are not extracted efficiently. The cutting edges can be chipped, as well as increased abrasive wear.

An extraction system with optimised extraction capacity and performance will help increase tool life.

Regular maintenance is essential for proper and safe use of tools.

Tools must be resharpened when:

- workpiece surface quality is no longer satisfactory
- the wear mark width (VB) on the clearance face is greater than 0.2 mm
- the machine's power consumption is too high
- sections of the cutting edge have broken away.

3. Tool servicing/Sharpening

This means reinstating the cutter sharpness of blunt tools, but also other repairs, for example replacing damaged cutting edges.

Servicing differs for the various materials, namely tipped high alloy tool steel, tungsten carbide or diamond.

Special machining processes are necessary to minimise the temperature rise in the cutters during sharpening to ensure crack free cutting edges, a cutting geometry according to the drawing, maintenance of the original dimensions and tolerances and a sharp cutting edge.

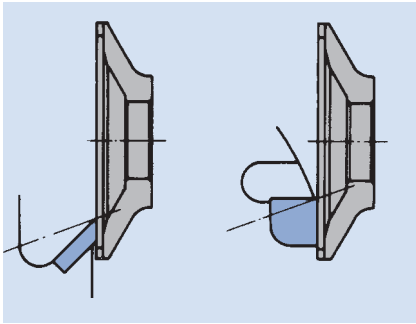

Sharpening on the clearance face.

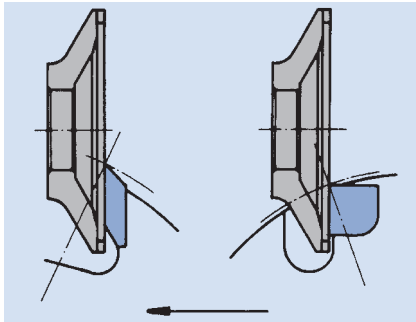

Sharpening on the cutting area.

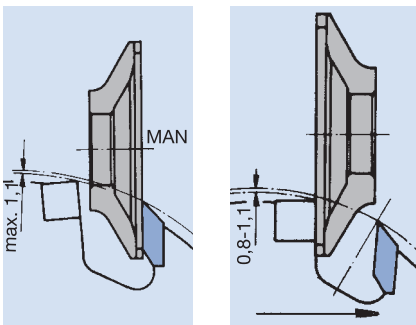

MAN tools: Knife protrusion in comparison to the limiters.

When servicing tools, the following has to be observed:

- the construction of composite tools must not be altered
- tipped tools must be serviced by trained personnel
- only spare parts to the manufacturer's original parts specification are used
- tolerances to ensure precise clamping, are retained.

To avoid damaging the cutting material by overheating or stress cracking, cooling lubricants must be used when sharpening.

Attention: Dry sharpening is not recommended.

The specified tool body radius should not be changed when sharpening, to avoid the risk of fatigue stresses.

3.1. HL, HS, ST and HW tools (solid or tipped)

HW tools are sharpened with diamond grinding wheels. Corundum or CBN grinding wheels are used for all the other cutting materials listed above.

Basic rules

- clean the tools thoroughly before sharpening
- maintain concentricity tolerances – check with a dial gauge
- spur projection beyond main cutter: 0.3 to 0.5 mm
- cutting edge projection should not exceed 1.1 mm above the limiter on manual feed tools

Tools with radial tipping

a) Grooving cutter with or without spur

These tools are always sharpened on the top, so as not to change the cutting width.

b) Jointing, rebating and bevelling cutter blocks

These tools are sharpened parallel to the face of the cutting edge or the spur.

c) Profile cutterblocks

The shape of the tips depends on factors such as the cutting material, profile depth etc. The clearance face can be one of three types (concave, straight, or convex), depending on the purpose of the tool. Sharpening always takes place on the face of the cutter, not on the profile!

Profile cutterblocks with straight or concave clearance face are sharpened parallel to the face; profile cutterblocks with convex back relief are sharpened by rotating around the cutter axis. The maximum permissible cutting edge projection for manual feed profile cutterblocks (MAN) is 1.1 mm and must not be exceeded.

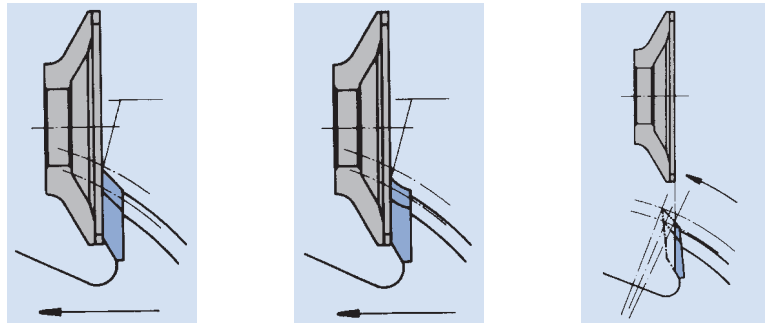

Straight clearance face. Concave clearance face. Convex clearance face.

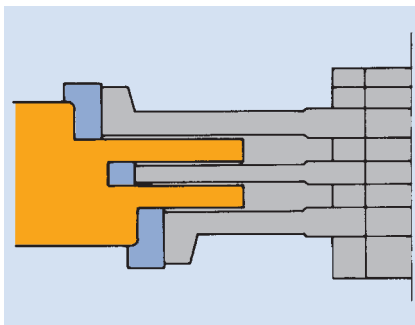

Slot and tenon cutter.

3.2. HS and HW slot and tenon cutters

The special blade tip geometry ensures constant rebate depths if the same amount is ground away from the face of every tip and removed parallel to the tip. For manual feed tools, the maximum permissible cutting edge projection of 1.1 mm must not be exceeded. After several sharpenings, the shimming must be adjusted (with a spacer set) to maintain the profile.

3.3. Cutterblocks and cutter sets

Single tools are sharpened as stated in guidelines 1 and 2 above. The amount removed during sharpening depends on the most worn cutter. All cutterblocks in a cutterset have to be sharpened to the same diameter to maintain the original workpiece profile.

3.4. Diamond tipped tools (DP)

Diamond tipped tools can only be sharpened or eroded on the top, using machines with special fixtures. Sharpening can be either by grinding or by spark erosion. Special measuring equipment is needed to check the sharpened tool. Diamond tipped tools can only be serviced at Leitz service centres with the necessary special equipment, or at the Leitz production plants.

3.5. HW tipped circular sawblades

a) General information

HW tipped circular sawblades should only be sharpened on special purpose automatic sharpening machines. Manual sharpening on universal sharpening machines cannot be recommended for quality and cost reasons. Automatic sharpening machines use a plunge cut grinding principle and are designed for wet grinding. Many of these machines are capable of sharpening all the standard and special tooth forms in a single cycle on both the face and the top. Sawblades must be thoroughly cleaned before sharpening.

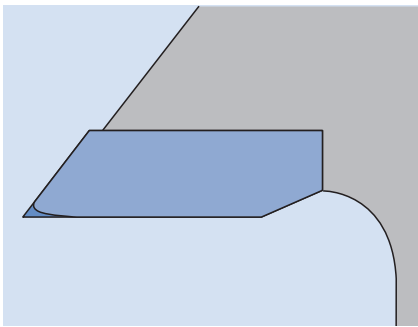

Wear on a HW saw tooth.

b) Reduction of saw plate and body

Only the tungsten carbide tips should be ground by the diamond wheel on automatic sharpening machines; the saw plate must be reduced behind the teeth and if necessary in the chip gullet as a separate operation. To avoid reducing the stability of the teeth unnecessarily, the HW tips should not project more than 0.2 mm (with SB < 3.2 mm) or 0.5 mm (with SB > 3.2 mm) above the saw body.

c) Resharpener

To sharpen a circular sawblade the maximum number of times, it is essential to sharpen both the face and the top of HW circular sawblades. As a rule, the removal ratio between the top and the face is 1:1 for solid wood machining and 1:2 for chipboard. Failure to remove the rounded-off areas at the tip edge completely reduces the tool life. The sharpening machine instruction manual will contain the necessary machine settings. Adjustment to the thickness of the sawblade is especially important, as teeth sharpened inaccurately will cause lateral sawblade runout.

d) Residual tooth height and thickness at end of life

When the tooth height measured from the tip seat is 1 mm, the sawblade is at the end of its life and should be scrapped for safety reasons.

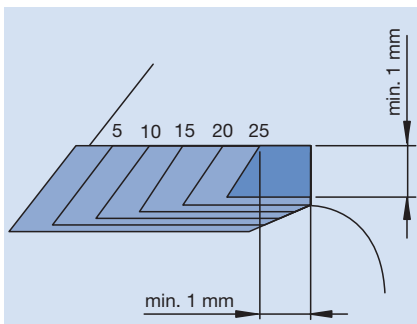

Leitz recommendation for the remaining tooth size on the sawblade.

e) Retipping

All Leitz service centres offer a replacement service for individual damaged teeth on HW sawblades. The new tip is applied by induction brazing using the correct braze and flux.

Expert knowledge of both the carbide composition and the saw body material is necessary. Users are recommended not to carry out this work themselves.

f) Flattening and tensioning

Flattening a sawblade means eliminating any twists in the plate for perfect flatness. Tensioning means stretching the saw plate at a point roughly half-way between the periphery and the centre. Flattening and tensioning are usually carried out as a single operation, and are essential for satisfactory sawblade performance. Sawblades should be checked regularly during resharpening for flatness and tension, and corrected if necessary. This is essential for multi-rip and thin-kerf sawblades, as these work in extreme conditions and can easily crack or fracture as a result. Sawblades severely discoloured by overheating should be discarded.

When in use, a sawblade should be supported by the correct flange; the flange diameter is based on the diameter of the sawblade. This relationship is laid down in German Industrial Standard DIN 8083. As a guide, the flange diameter should not be less than a quarter but preferably a third of the sawblade diameter.

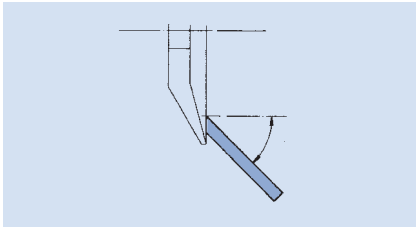

Sharpening of planer knives.

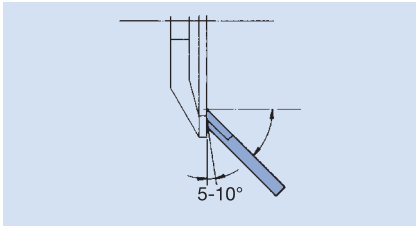

Recessing of the knife basic material of HW-tipped planer knives.

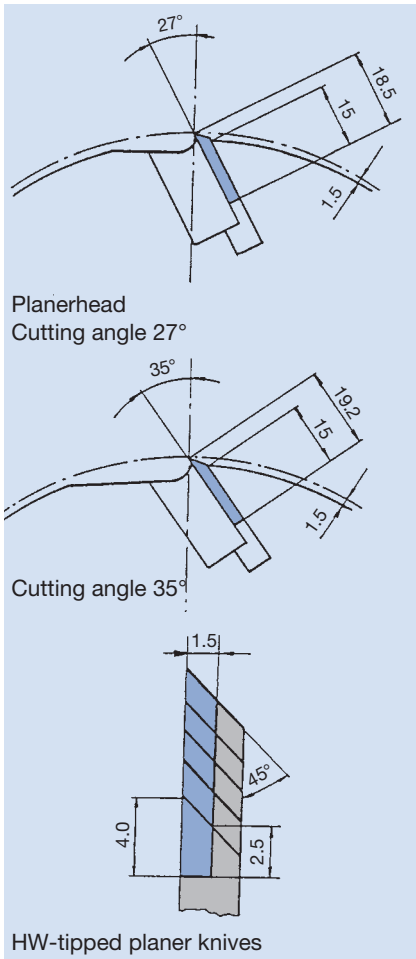

HW-tipped planer knives

Allowed minimum dimensions of planer knives.

3.6. Hoggers

a) Hogging cutters

Hoggers consist of a sawblade and a hogging cutter screwed together. Hogging cutters must be ground on the top of the teeth and occasionally on the face, so that the relationship between them and the sawblade is maintained. As the teeth are of equal pitch, it is more efficient if they are sharpened on an automatic machine. The hogging cutter has to be mounted on a special fixture for this operation.

b) Segment hoggers

Segment hoggers consist of hogging segments and a sawblade. The saw segment can be ground either while mounted in the hogger body on a conventional cutter sharpening machine, or dismantled from the hogger body and mounted in a special fixture for an automatic sharpening machine (as used for HW circular sawblades).

c) Compact hoggers

A diamond compact hogger (DP) is sharpened by erosion on all three edges (side, bevel and top), on a special machine. If the tool is mounted on a hydro sleeve during operation, sharpening must be carried out with the same level of clamping to achieve high concentricity and runout accuracy.

3.7. Cutterheads

It is essential to follow the below when mounting planer knives:

- 1) All the tool body locating faces, knives and clamping elements must be clean and undamaged.
- 2) The clamping screws should be tightened from the centre to the outside (for larger cutting widths).
- 3) The knife setting should be checked with either a dial gauge or a setting gauge (for planer knives).
- 4) Do not use an extension to the wrench or key when tightening the bolts or screws.
- 5) Spurs should sit perfectly in their seats before the screws are tightened.
- 6) Cutterheads should be mounted on a suitable spindle when tightening the bolts or screws, to avoid distorting the body.
- 7) Seats and wedges in cutterheads must not be modified in any way as they are specifically designed for maximum safety.
- 8) All knives and clamping elements should be of equal weight.
- 9) New knives and clamping elements mounted in opposed seats should have the identical weight to avoid imbalance.

a) Planer knives

HL, HS and HW planer knives are ground only on the back to maintain the original angle. To prevent the diamond wheel from touching the tool body when resharping the knives, the clearance from the steel backing must be 5 to 10° less than for the actual carbide tip.

Comply with the dimensional tolerances when sharpening planer knives. The minimum clamping width should not be exceeded (see the marks on the side of the tool body).

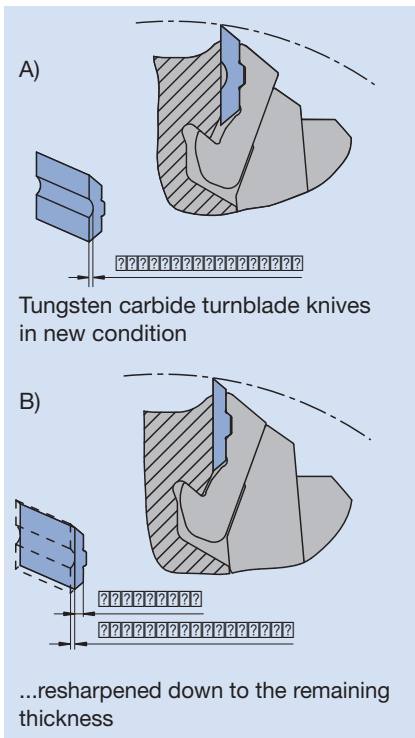

Sharpening of VariPlan knives.

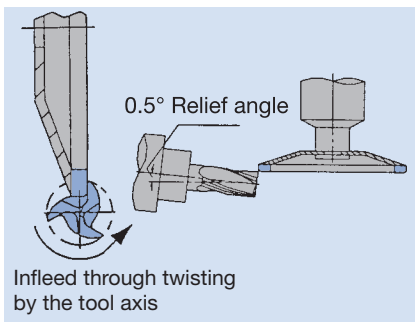

Sharpening of spiral routers.

For a minimum clamping width of 15 mm and a radial knife projection of 1.5 mm, the minimum knife height is 18.5 mm for a cutting angle of 27° and 19.2 mm for a cutting angle of 35°.

Hydro cutterheads have a radial knife projection of 4 mm; for the same minimum clamping width, the minimum knife height is 21.3 mm.

Note, the minimum tip height must be at least 4 mm on HW tipped planer knives.

b) VariPlan planerhead

The cutter has straight, face-sharpened turnblade knives which can be sharpened. The knives have a raised trapezoidal area on the back and are mounted in a special fixture for sharpening.

The resharpening area of 1 mm is shown by the groove in the knife face. The clearance angle is matched to the clamping mechanism in such a way that after resharpening, the diameter of the tool remains constant and the clearance angle must not be changed.

c) Spiral planerhead

Sharpening the 1 mm thick flexible HS knives requires a special fixture supplied by the manufacturer. After sharpening, the knives are clamped in the cassette to the correct three-dimensional pattern. The user can then install the complete knife cassette in the spiral planerhead.

d) Profiled knives

Profiled knives are ground on the edge of the profile; the possible sharpening area and minimum knife clamping heights must be complied with.

The cutting edge quality and the life time can be improved, if one level is ground with a second clearance face, which is about 3° to 5° smaller than the main clearance face. Radial profile sectors additionally require a lateral clearance face.

3.8. Tools for routing

a) HS and HW spiral routers

These tools are manufactured in one of two designs: either as a finishing cutter with maximum chip removal of 1 to 3 mm, or as a roughing cutter for high hogging performance.

Roughing cutters are resharpened only on the face because of their special profile. Finishing cutters can also be resharpened on the clearance face.

b) HS and HW routers with shear angle

These are face ground. If the cutting edge is chipped, the back can also be ground down to the next possible nominal diameter. The body must be set back at least 0.7 mm from the knife cutting circle.

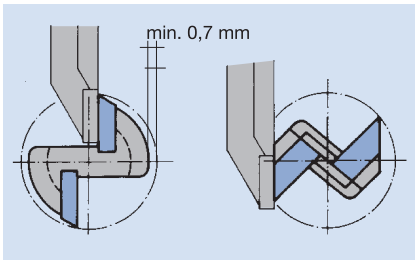

Sharpening of routers with straight edges.

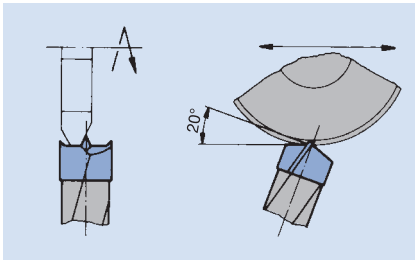

Sharpening of dowel drills.

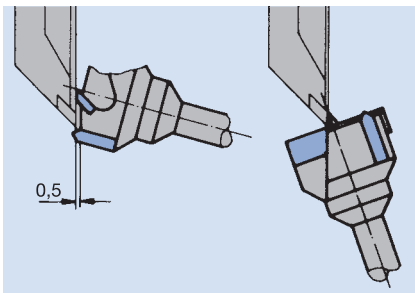

Sharpening of hinge boring bits.

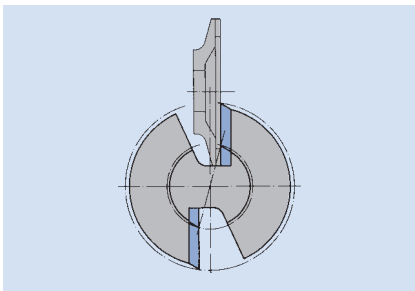

Sharpening of HW-tipped profile routers.

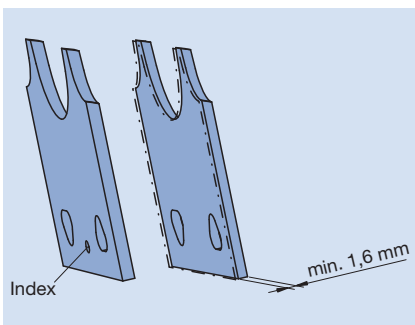

Sharpening of VariForm knives.

c) HW tipped dowel drills

Clamp the drill firmly in a collet before sharpening, to ensure high concentric running accuracy. HW tipped dowel drills are sharpened on the cutter edge, centre point and spur in one operation with a profiled diamond wheel. The projection of the centre point and spurs above the tool body must be maintained. Profile diamond grinding wheels are available for all frequently used diameters.

d) HW tipped hinge boring bits

Clamp the tool firmly in a collet before sharpening. The centre point and spurs are ground in a single operation. Before sharpening the edges of the main cutters, the tool body must be set back so that it is 0.5 mm below the main cutter. The spur should project above the main cutter by 0.3 to 0.5 mm; the centre point should project by 1.5 to 2.5 mm. If there is excessive wear, the main cutter can also be sharpened on the face, but only resharpened as far back as the centre of the bit.

e) HW tipped profile router cutters

Profile router cutters are subject to the same sharpening guidelines as profile cutterblocks (see 3.1c). Profiled routers are clamped firmly in a collet before sharpening to maintain high concentric running accuracy. The restricted gullet geometry of MAN tools may require the use of thin, small diameter grinding wheels.

3.9. ProFix knives

HS and HW tipped ProFix knives are sharpened on the face after removal from the tool body and mounting in a pivoting fixture fitted to the table of the sharpening machine. This allows knives with different cutting angles (15°, 20°, 25°) to be aligned parallel to the sharpening direction. HW tips can be ground down to a minimum thickness of 0.5 mm, ensuring a high material utilisation.

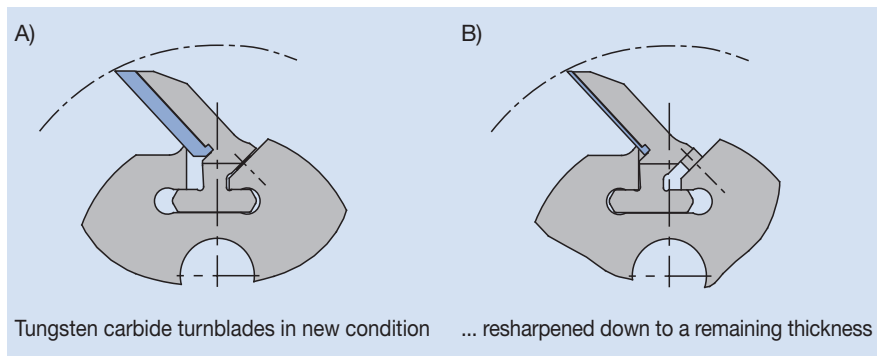

Sharpening of ProFix knives

3.10. VariForm profile knives

VariForm cutterheads (HW) are ground parallel with a diamond wheel over the entire front face of the knife (the cutting face).

Special grinding machine fixtures are required; these are installed at Leitz service centres.

The sharpening area is identified by a circular hole in the cutting face. Once this hole has disappeared, the knife has reached the end of its useful Index life and cannot be resharpened any thinner (minimum thickness 1.6 mm).

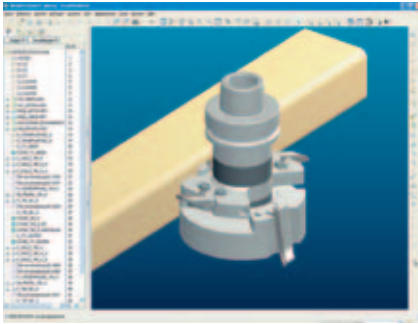

Modern construction methods through 3D-CAD.

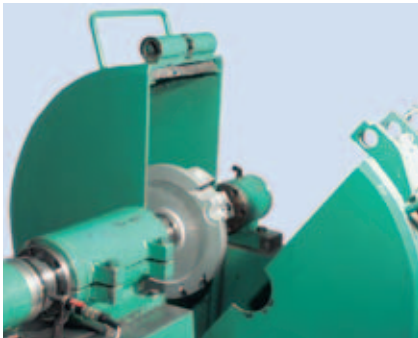

Centrifugation test facility.



Labelling example of boring tools.



Labelling example of shank routers with a minimum clamping length.



Tool with integrated data chip.

Tools for woodworking machines are potentially dangerous because of their high speeds and sharp cutting edges. Always use machine guards and only use tools tested for compliance with the technical safety requirements to reduce the risk of accidents.

Safety at Leitz

The highest level of product safety is important to Leitz as a major tool manufacturer. All Leitz tools are designed and manufactured to EN 847 standards and take the latest safety research findings into consideration. The basis for safe tools is established at an early stage in their development, as can be seen from:

- modern CAD techniques and calculation methods such as the Finite Element Method (FEM)
- extensive testing including overspeed and reversing tests in the Leitz research department
- tool certification according to the independent industrial accident tests laid down by the Deutsche Holz-Berufsgenossenschaft (German Wood Trade Industrial Accident Insurers).

Manufacturing procedures checked and documented to DIN EN ISO 9001 and a certified quality management system guarantee the high quality and safety standards expected of tools supplied by Leitz. Support from Leitz – including local Leitz sharpening centres satisfy customers' needs and advice from technical specialists – ensures the safety of the tool throughout its life.

Safety in use

A tool is only as safe as how it is used by the operator. Detailed, easily understandable instructions on the safe use of the tools are just as important as their safe design. Leitz cooperated in the VDMA project to develop specimen instruction handbooks for different types of tools. These layouts are now used not only for Leitz products but are also recommended by the European woodworking industry association EUMABOIS.

Users are given the relevant safe handling information by the information etched on the tools, the maximum rotating speed, method of feed, minimal clamping length for shank tools etc.

Intelligent tools with integrated memory chips are available for CNC machining centres. These tools automatically supply the machine control system with the relevant geometry and technology data such as tool length, tool diameter, recommended running speed, direction of rotation etc. The risk of manual input errors is reduced ensuring high operating safety and process reliability.

The comprehensive safety instructions supplied by the machine manufacturer should be followed when using tools. The guards on the machine are to protect people and should not be modified or removed. Internationally accepted pictograms advise of any potential danger.



Safety guidelines

Leitz and the other well-known German tool and machine manufacturers are members of the Association of German Machine Manufacturers (VDMA). Leitz’s long experience has contributed to national and international standards and regulations for the safe construction of woodworking machine tools and for operator safety throughout the world.

The EN 847 series of European standards, parts 1 to 3 „Machine tools for woodworking – safety requirements” are the most important guideline for European tool manufacturers. Woodworking tools must comply to these minimum standards to be considered safe.

One of the aims of manual feed tools is to reduce kick back. The small gullet size and limited cutter edge projection reduce the severity of injuries. This is evident by the steady reduction in the number of accidents notified annually to the industrial accident insurers.



ISO 3864, U.S. ANSI Z535
VDMA woodworking machines.



Safety labels
Pictograms for handling, function monitoring and maintenance - woodworking machines

Important Note:
Tools and clamping tools are not subject to machine guidelines and are not allowed to have the CE-Sign.

EN 847-1	Machine tools for woodworking – safety requirements Part 1: Milling and planing tools, circular sawblades
EN 847-2	Machine tools for woodworking – safety requirements Part 2: Requirements for shank milling tools
EN 847-3	Machine tools for woodworking – safety requirements Part 3: Clamping tools

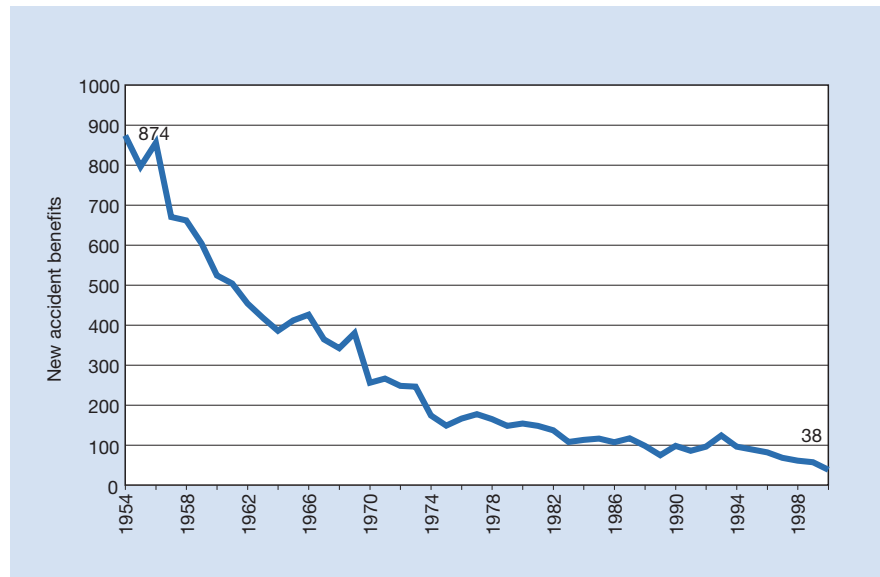

Constant decrease of the „new“ accident benefit (source: Holz BG)

11.4 Machine tools

11.4.6 Low noise tools



Tire profile with irregular pitch.



UT-hogger with irregular pitch.

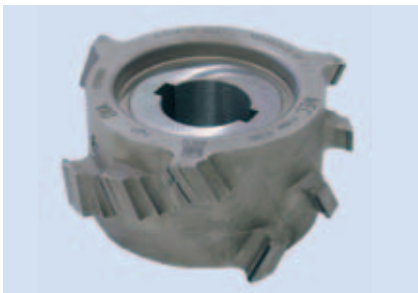

A) Conventional jointing cutter
91,5 dB(A).



B) Jointing cutter „WhisperCut“
86 dB(A).

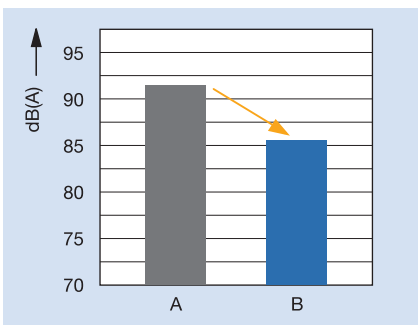

Noise reduction for jointing cutters.

In addition to dust, noise is a major problem in the woodworking industry. It is important when developing new tools to reduce noise levels at source and to prevent them from increasing. If the level is lowered by 10 dB(A), the human ear perceives this as a 50% reduction in noise. The latest low noise tool systems considerably improve the users' working environment.

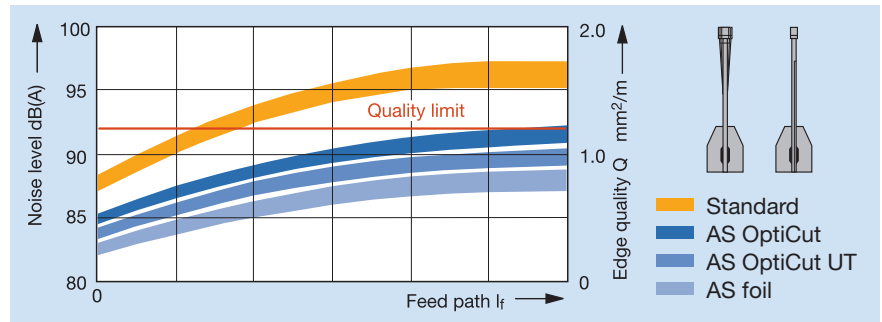

Axial body vibration of a plate type tool such as a sawblade causes noise radiation. The vibration amplitude can be significantly reduced by the design of the teeth, gullet geometry and by damping the saw plate. Leitz supplies a choice of designs of low noise sawblades (AS) which take into account all the criteria, the machine and the materials to be cut.

- A) AS sawblade with foil (vibration damping by friction between sawblade and foil)
- B) AS OptiCut UT sawblade (irregular pitched teeth suppress harmonic vibrations in the sawblade)
- C) AS OptiCut sawblade (laser ornaments in the sawblade body reduce natural resonance and vibration disturbing the sound waves).

Cutting edge airflow turbulence is another cause of noise as it stimulates vibration in the sawblade. When the cutting tips touch the workpiece, tool and workpiece vibrate. Varying the distance between successive cutting tips counteracts harmonic vibrations and dampens both free running and cutting noise.

The principle of irregularly pitched teeth (UT) is applied to both sawblades and profiling tools.

Research has also been carried out on ways to reduce the noise generated by cutting tools. A closed circular tool body shape, a profile that matches the tool body and optimised gullet geometry result in significant noise reduction. Today's diamond jointing tools with these features generate half the noise of their predecessors. But there are other, fully intentional, benefits from noise reduction. Reduced vibration means that the tool runs more smoothly, in turn leading to better cut quality and a longer tool life.



Laminate processing: Typical chip collection in the machine.

Every woodworking production process causes chips, chips to be extracted. Despite state of the art extraction systems, not all the chips are collected. Whether processing solid wood or panels, uncollected chips have a negative impact on added value. They reduce the product quality, make additional tool cleaning necessary, increase machine downtime and can cause machine breakdowns through wear. Leitz's answer to this problem is DFC® (Dust Flow Control).

DFC®

The philosophy behind DFC® is to control the chips by using the kinetic energy in the chip flow to direct the chips away from the workpiece and tool cutting edge into the extraction system.

This improved method of chip collection has the following advantages:



Problem: Machine wear through abrasive chips.

- Energy saving
The extraction airflow no longer has to capture the chips, only transport the chips into the extraction system. This reduces the required airflow volume and, in winter, reduces heating costs, as the heated air is not being taken from the factory.
- Improved product quality
Sensing systems are not impaired in any way by chip impairing them or glue spillage.
- Higher productivity
Clean machines mean continuous production without stoppages. Clean workpieces do not need additional cleaning prior to packaging.
- Reduced servicing costs
The abrasive chips are directed away from expensive machine elements and dispel their energy against replaceable wear parts such as guides or dust hoods.



DFC® tool for directed chip beam.
DFC®-system: Tool with adapted extraction hood. Most of the chips are collected and the wear is kept away from the machine.

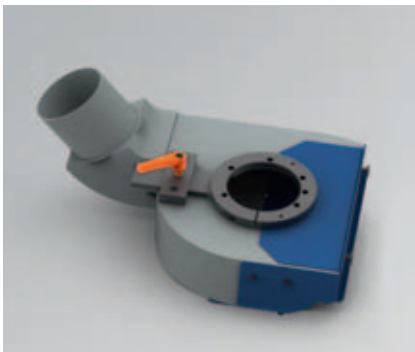

Module-based DFC® extraction hood with exchangeable wear baffle plates, adjustable tool passage with secondary air supply system and detachable lid for good accessibility to the tool.



A sound-insulated design can additionally optimize the machine with regard to noise.

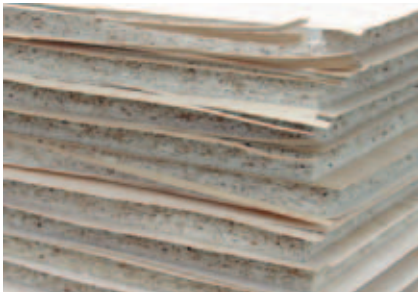

Example: Hogging of veneered panels with free veneer projection.

Applications for DFC® tools:

DFC® technology is available for hoggers, jointing cutters, profile cutters, grooving and shank tools; it is the subject of ongoing continuous development. The best results are achieved when the tool and the extraction system are matched to each other. Examples of DFC® system solutions are:

- *IQsystem*

Developed with the machinery manufacturers for efficient chip collection on edge banding machines – over 95% efficient.

- DFC® tools for laminate and parquet flooring production with matched extraction hoods, e.g. „i-flooring“: significant reduce wear caused by abrasive chips to the machine guides and feed systems.



Broken splinters block the extraction hood - fire risk through friction of the rotating tool!

DFC® tools are important in hogging; the problem of continuous high volume chip output cannot be solved simply by increasing the extraction velocity. The chips must be directed as produced in the right direction. The effect cannot be seen so easily as on CNC machining centres when sizing panel materials. Often compromises have to be made in the design of the tool, the working method and chip flow.



DFC® hogger with shredding edges shred the veneer projection on an extractable size for a complete disposal.

Chips can clog the extraction hood and a fire risk from friction with the rotating tool. Chips can also block the extraction pipes and stop production. A well known example is machining veneered panels where the coating projects over the edge of the panel. Conventional tools do not break up the weak projecting coating causing the long strips of veneer to clog the extraction system. Such blockages can cause machine fires. DFC® hoggers with shredder knives solve the problem by breaking the overhang into small, easily extracted pieces.



Splitting of worktops with DP-routers. Conventional router: Chip beam horizontally leaves the workpiece and shoots through bristle curtains or vertical blinds.



DFC® router: Chip beam is directed to the top of the extraction hood and can be extracted.



Tool with QR Code

In the early 1990s, Leitz introduced the wood processing market to chip tools as „intelligent tools”, storing all a CNC tool machines’ relevant data on integrated memory chips. This provided the machine control center with essential geometry and technology data including RPM, direction of rotation, diameter, tool length, reference points coordinates, and if the application was known, even the recommended application speed and feed speed.

The machine transferred all this data in the tool memory device, which had the benefit of needing no calibration, reading the data straight into the machine controls. This improved process safety by preventing errors during adjustment of the machine. However, an issue was the lack of standardization of data; the tool needed to be programmed on a machine-specific basis and could not be used on machines from different manufacturers.



Tool with DataMatrix Code

With the rise of digital-controlled manufacturing, cyber physical communication between all operating resources has become increasingly important. For this, tool data is stored in a central database. It is encoded with an automatically readable and unambiguous identification-number: RFID Chips or DataMatrix Codes. Access to the data takes place via this serial number. For manufacturing tool data exchange, a crucial prerequisite is a standardized data model with uniform nomenclature and uniform structure of parameters. The tool acts as knowledge mediator and consequently becomes the key factor for the optimization of the entire production processes and value chains.



Tool with integrated RFID Chip

The advantage of central data management is that much more information can be transferred; data can be retrieved at any time without physical access on the tool. Not only can tool data be read into the machine control but also machine data like tool life and power consumption can be assigned and written back to the individual tool. In this way a learning system is made possible that anticipates a tool replacement. Pure parameters used by the machine control as well as tool contour data can be transferred to the control unit in order to carry out process simulation and collision detection. By linking tool data with material data and application data, an expert system can be created that recommends the right tool with appropriate parameters to the customer for their machining task.



Tool with integrated NFC Chip

At the highest stage of networking, tool data is provided from the cloud. Access to the data can be assigned to different authorization groups or user groups. Each tool has its individual valid data record which can be updated by the Sharpening Service if tool parameters have changed as a result of resharpening or rework. Tool-related tool life data can be transferred to the tool manufacturer providing the basis for optimizing processes and for pay-per-use billing models.

Imaginable is also a hybrid type between data storage on memory chip and a cloud solution, depends on the existing IT improvement and IT firewall concepts. Here the tool is data medium for necessary safety and performance data and at once other additional information as application parameters, running time parameters or CAD data can be viewed in the cloud.

TOOLMAINTENANCE



OPERATOR



TOOL MANUFACTURER



MACHINE MANUFACTURER

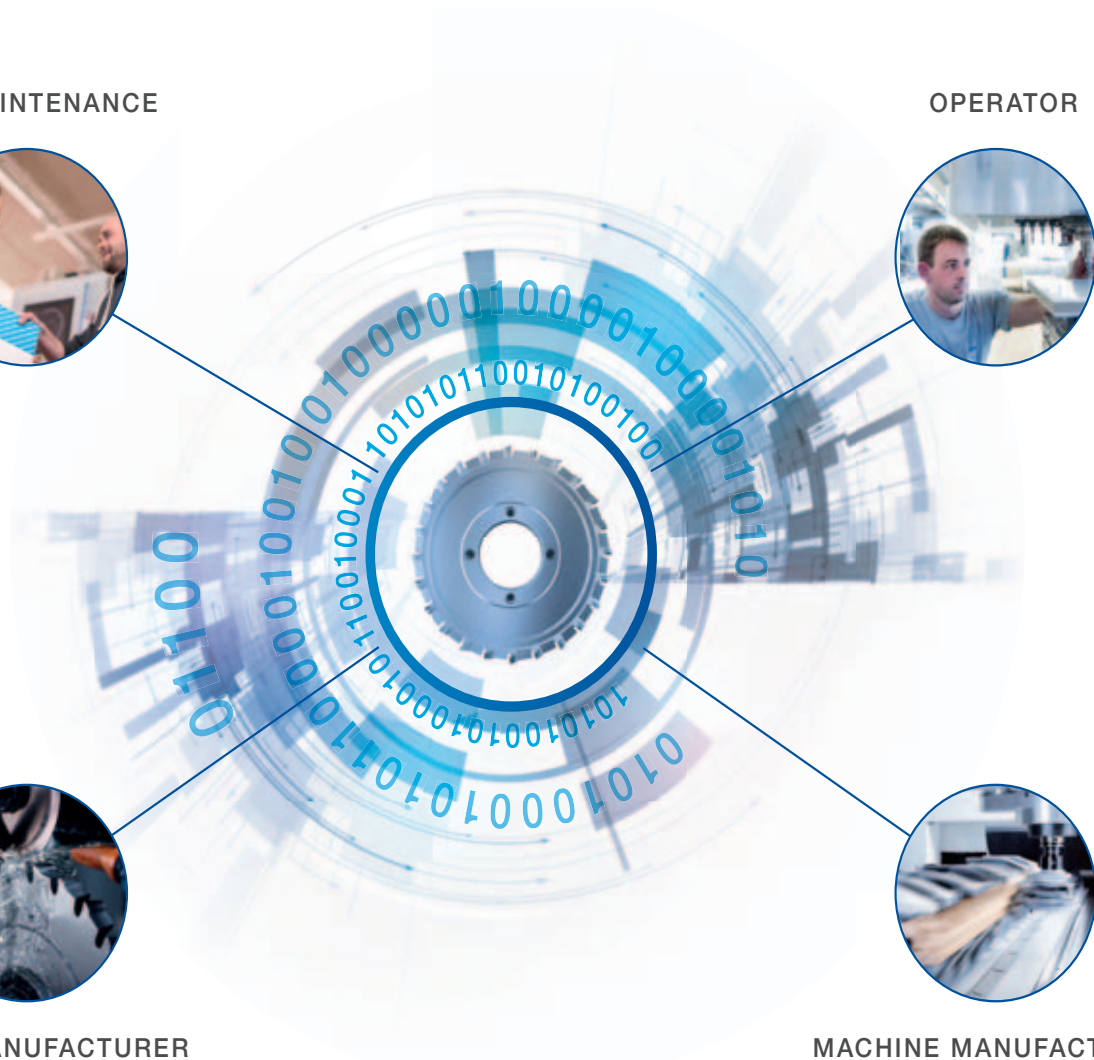

11.5 Wood processing machines

11.5.1 Through feed machines

There are two different categories of wood processing machines with mechanical feed: through feed and stand alone machines.



Detailed view of an edge banding machine with chain feed.



Detailed view of a four side planing and profiling machine with roller feed.

If the workpiece is guided through the machine by a feeding unit, it is called a **through feed machine**. The machining processing is made by guiding the workpiece past the tools. Several tools may be used subsequently, to fully process the workpiece. Depending on the type of feeding systems, a distinction is made between machines with chain feed and machines with roller feed.

Machines with chain feed are used to process the narrow sides of panel materials. The feed chain is used as the workpiece support and reference height for the process. A revolving top pressure belt clamps the workpieces to the chain and transports them through the machine. The part of the board workpieces protruding past the chain can be processed. The chain's uncoiling movement from the chain wheel, can cause minor variations in the feed; this is called the polygon effect. Such effect is counteracted structurally so that the polygon effect does not affect the processing quality. Typical examples for such machines are double end tenoners and edge banding machines for furniture components or machines for profiling laminate panels or parquet floor panels.

Machines with roller feed are used for four sided processing of solid wood or wood derived products. Typical examples of this machine category are multi spindle four side planing and profiling machines for manufacture of blanks, mouldings and profile panels. The workpieces are pushed along the machine table by driven feed rollers and guided along a fence. The roller feed, is smooth so the wood surfaces are ready for painting. It is also important for the processing quality that the workpieces are guided past the processing tools straight and without vibrations. The tools' zero diameter has to be set exactly to the table height and lateral guide in order to produce accurate workpiece surfaces. Constant tools save time since their zero diameter remains unchanged. Additionally sufficient support of the workpieces against the cutting pressure is important in order to avoid workpiece vibrations and rippled surfaces. The pressure shoes at each processing station must be set exactly to the workpiece dimensions. Chip extraction is also important.

Through feed machines enable a **high production performance** since all processing steps on one workpiece are made almost at once. These machines are designed for bigger batches since retooling is time consuming. Following the **trend towards smaller batch sizes**, elements from stand alone technology are now integrated into feed through machines: e.g. engines with HSK interface, preset tools, automatic tool changer, tracing aggregates, contour milling cutters or through feed drilling. To further increase the feed rates, dynamic linear actuators are used for the tracing aggregates.



Cantilever type machining centre

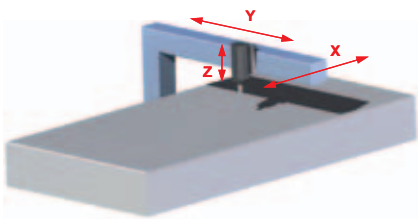

Schema of a cantilever machine

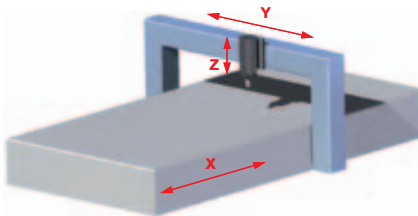

Schema of a portal machine

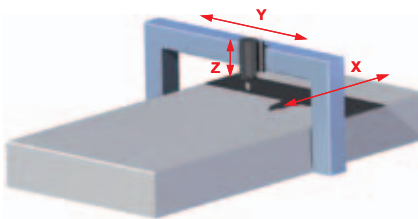

Schema of a gantry machine

In **stand alone machines** the workpiece is clamped firmly, and the feed movement is achieved by contour controlled axis or the workpiece table. Depending on the arrangement for the moving axis, the different designs are called travelling column, portal or gantry. In the **travelling column design**, also called **cantilever**, machine spindle is situated on a mobile cantilever and executes the feeding movements in all three axis. In case of the **portal design**, the machine spindle which is mobile in Y and Z direction is situated on a fixed portal, and the feeding movement in X direction is made by the workpiece table. Such machines often are equipped with tandem tables, so one table may be loaded and unloaded by a handling system while processing is under way on the second. The **gantry design** is a **travelling portal** carrying the machine spindle. All feeding movements are achieved by the tool, similar to the travelling column design. Due to the bilateral support of the travelling portal, the gantry machines are more dynamic than the cantilever machines and often used for the nesting.

Coming from point-to-point drills and CNC routing cutters, these stand alone machines have been developed into complex **processing centres**. When equipped with drill drives and additional aggregates, they can machine the workpiece, drill it on all sides, saw and even edge band so that a component may be processed in one setting. The machines are made flexible by a tool magazine and automatic tool changer. The main spindle is usually designed to use a HSK interface; HSK-F 63 and also HSK-E 63 are common in wood processing. Since the tool diameters range between 3 mm to over 200 mm, the motor spindles are frequency controlled to a maximum speed of $24,000 \text{ min}^{-1}$ or up to $30,000 \text{ min}^{-1}$ for HSC machines.

CNC-controlled machines allow flexible component manufacturing with a batch size of one. The software determines what process by which tools. The process task is changed by calling up a new CNC program on the control. Despite this theoretical flexibility, the component spectrum processed on one machine depends on the **workpiece clamping technology**. Beams may be positioned freely and with vacuum extraction clamps for panel workpieces or mechanical clamping devices, for window blanks, may be positioned. Additionally there are vacuum tables for clamping of bigger boards e.g. for nesting. Mouldings without level clamping surfaces, e.g. backrests, are clamped by specially manufactured templates that are set on the beams or vacuum tables mechanically or by vacuum as an auxiliary device. The arrangement and distance of the extraction or clamping devices on vacuum table are very important for the processing result. If the distance is too great, workpiece vibrating reduces the processing quality and tool life. Bigger pieces of waste should be clamped so they do not break off, damaging the tool.

Since all operating sequences on stand alone machines run one after the other the processing times are longer than on through feed machines. On the other hand, any shape can be produced, and the components are finished. To increase productivity various methods are employed. Each machining process is sped up by smaller tool diameters and higher spindle speeds. The movement dynamics are increased by employing linear actuators. By having multiple tools on one arbor, tool changing times are reduced by placing the tool in a different working position instead of replacing it. By using several independently controlled main spindles, operating sequences occur in parallel. Moving workpiece clamping systems with part transfer enable a workpiece to be fed through the machine.

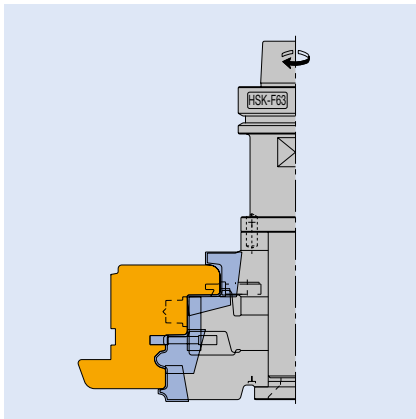

Rebating with a 3-axis machine

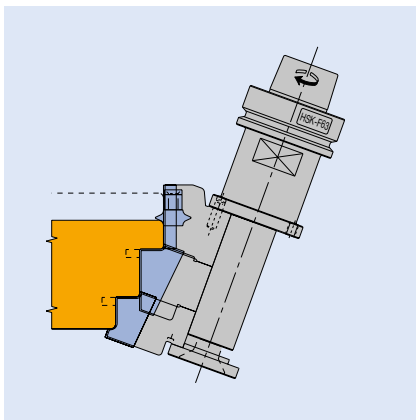

Rebating with swivelled spindle on a 5-axis machine

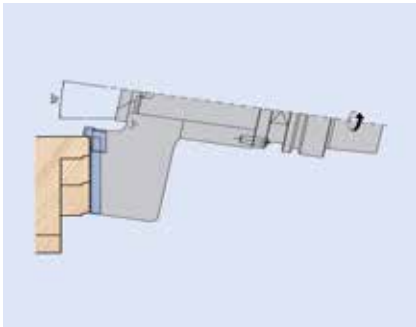

Taper-surface planing of visible surfaces, for example window profiles:
No visible knife marks.

Another trend in stand alone technology are **5 axis machines**. For wood processing machines, the 4th and 5th axis are usually two additional spindle swivelling axis. There are two types: cartesian and gimbal 5 axis machines. Both systems have a vertical swivelling axis for the spindle as a 4th axis. In the cartesian system the motor spindle is rotatable around a horizontal axis in a „fork“. In the gimbal system the spindle swivels around an axis by 45°.

A classic application for **5-axis machines** is processing 3D moulded parts, for example model making, mould making or boat building. However, this requires a CAD/CAM interface to program the control the five axis. In wood processing, the trend to utilise the 4th and 5th axis to swivel the main spindle is more widespread. It is possible to minimise the use of aggregates since bevels, saw cuts and holes can be made with standard tools on the main spindle. Additionally the quality of rebates can be increased by the same entry conditions at both sides of the rebate by using a inclined spindle. Tool life of double rebate profiles increased as the tool profile depth is reduced and the differences of cutting speed and operating path of the knives are decreased.

A special application is taper-surface planing, working with small adjustable angles on spindle. Efficient tool diameter can be reached through a big taper angle. This means no visible knife marks on the processed surface.

11.5 Wood processing machines

11.5.3 Machines for manual feed

Manual feed machines are stand alone machines and the workpiece is usually fed by hand. The machine table is the supporting surface for the workpieces. The workpieces are guided past the tool by a sliding table of fence. Workpieces with shaped edges are guided by templates. Special tools with ball bearing guide rings are required. In principle, the same variety of workpieces as on machines with mechanical feed may be manufactured on machines with manual feed. Manual feed machines for one-off products or repair parts are essential in plants for industrial mass production.

Typical examples of stand alone machines with manual feed are **circular saw benches, surface planing machines** and **vertical moulding machines**. They can be equipped with mechanical feeding devices (power feed) in addition to the manual feed but still are considered manual feed machines.

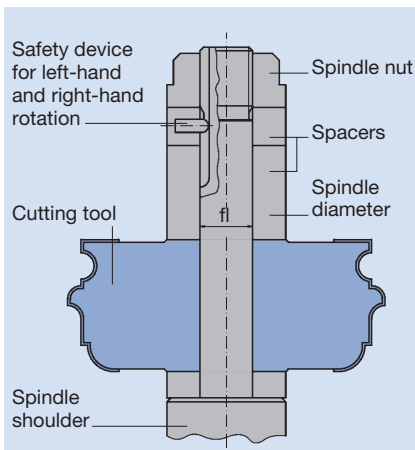

Example of a tool mounting on a spindle moulder.

The operator creates the feeding movement and is involved in the machining process and is exposed to a higher risk than machines with mechanical feed. The highest risk is the rotating tool since the cutting area is not enclosed. The machine directive for machines with manual feed stipulates numerous protective devices. Their use is stipulated in the national accident prevention regulations, their use is the user's responsibility. Protection against touching the rotating tool, preventing workpiece kickback and dust and noise are covered by the regulations. Extraction hoods have the function of a protective device and at the same time serve as noise protection.

Important safety requirements for working with manual feed machines: Only tools marked with „MAN“ designed with particular kickback limitations to EN 847-1 may be used (except for circular sawblades). The tool mounting on spindle moulders must be effected by a safety against twisting in order to prevent an accidental opening of the tool. The free spindle length has to be filled up with spacers, so that the clamping nut can transfer the clamping power to the tool. To prevent workpiece kickback you have to work against the feed (except for scoring). Short workpieces must be fed by a push stick to keep the hands as clear as possible of the hazard area. Openings between the tool and the machine table or lateral guides must be as small as possible. For stopped straight work stoppers for a defined pivot movement of the workpieces must be attached additionally. Circular sawblades must be operated with a riving knife adjusted to the sawblade diameter and the thickness of the saw kerf to prevent the sawblade jamming in the cut and the workpiece from being thrown back. For cutting edges without tears there are special scoring aggregates scoring the bottom of the workpiece to a cutting depth of approximately 1 mm with the feed before the separating cut is made with the main sawblade. The scoring sawblades create a cutting kerf about 0.1 to 0.2 mm wider than the main sawblade.

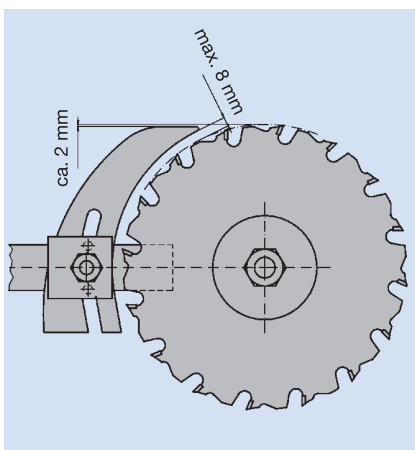

Correct adjustment of the riving knife on spindle moulders

11.5 Wood processing machines

11.5.4 Hand operated electrical tools



Swing cover saw



Plunge saw



Portable router

Typical examples for hand operated electrical tools are circular hand saws and routers. Like stand alone machines they have a „table“ as a supporting surface for the workpiece; however, it is situated above the workpiece since the machine is placed on top of the workpiece.

There are two different designs for **circular hand saws**:

- a) Swing cover saws b) Plunge saws

Most wide spread are **swing cover saws** that are usually available for bigger cutting depths. As the name indicates swing cover saws have a swing mounted protective cover that closes automatically after cutting. Plunge saws have a one part stationary protective cover. The complete motor and sawblade unit swivels back into the initial position after cutting so the sawblade disappears into the protective cover with these machines.

Plunge saws are used when it is necessary to make a plunge cut. On newer plunge saws, the splitting edge is spring loaded to allow for swivelling when making a plunge cut. There are various edge guide and guide rail systems available for circular hand saws, allowing for clean and most of all accurate saw cut. Only use under exceptional circumstances or when making a rough cut.

Usually, circular hand saw machines do not have scoring. A better cutting quality is obtained on the workpiece's underside. And to achieve a workpiece upper side without tears (teeth exit side) it is recommended to score the top at a depth of approximately 1 mm first and to make the separating cut subsequently with a lateral set off of approximately 0.1 mm.

Hand router machines are versatile machines with almost unlimited uses. The following illustration gives an overview over the most important processing possibilities.

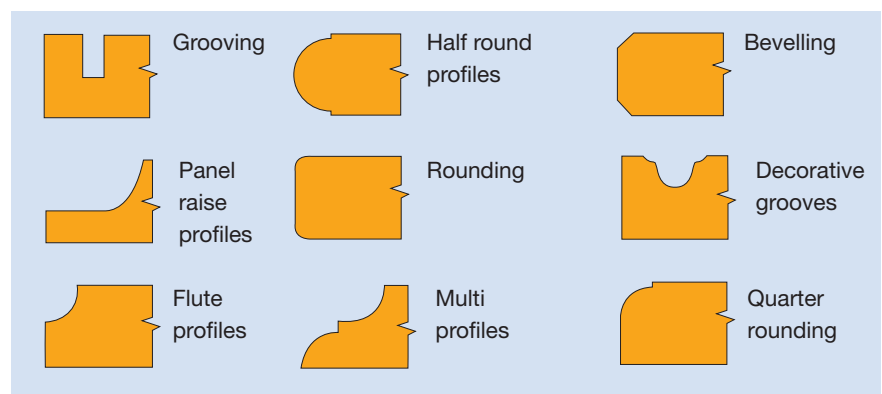

In most instances the tools for hand router machines have bearings or guide surfaces disks to guide the machine along the workpiece edge. Another method is working with templates. This means that a template is mounted in the machine table allowing an exact reproduction by following the contour. Sizing cuts or machining of grooves are best made by edge guides or guide rail systems. Round parts can be created by using a circular aid, similar to a compass.

11.5 Wood processing machines

11.5.4 Hand operated electrical tools



Cutting tool with guide ring for portable router.

Hand router machines are often used for flush milling veneer or laminates glued to sized boards with an overhang. Router tools with the knife cutting radius equalling the bearing diameter are used. Often no effective extraction is available due to the limited space on hand routers. When grooving/profiling, chips may be extracted by an extraction pipe.

