

# Knives and spare parts

Leitz Lexicon Edition 7

Version 2

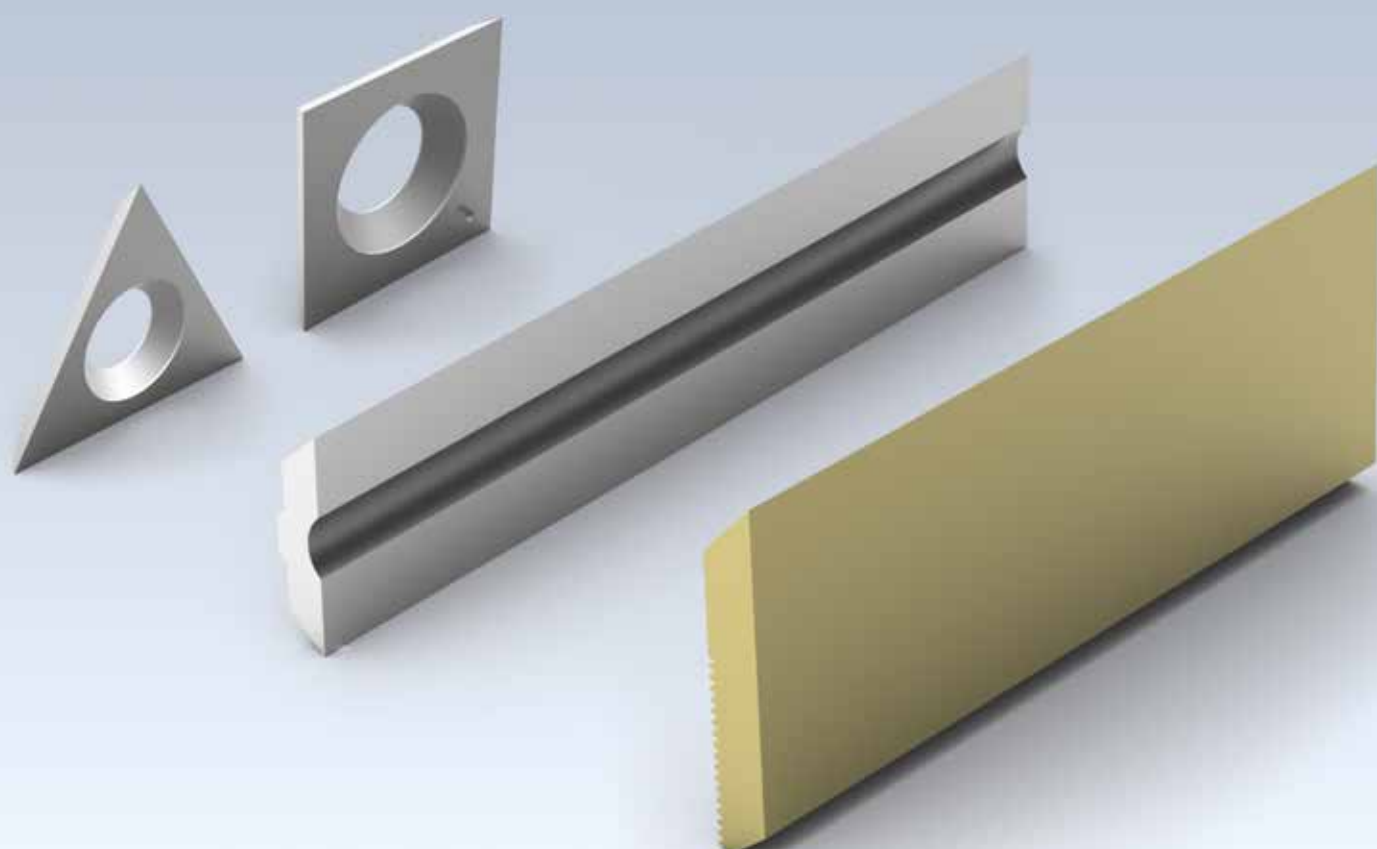

## Explanation of abbreviations

A	= dimension A	LH	= left hand rotation
$a_e$	= cutting thickness (radial)	M	= metric thread
$a_p$	= cutting depth (axial)	MBM	= minimum order quantity
ABM	= dimension	MC	= multi-purpose steel, coated
APL	= panel raising length	MD	= thickness of knife
APT	= panel raising depth	$\text{min}^{-1}$	= revolutions per minute (RPM)
AL	= working length	MK	= morse taper
AM	= number of knives	$\text{m min}^{-1}$	= metres per minute
AS	= anti sound (low noise design)	$\text{m s}^{-1}$	= metres per second
b	= overhang	n	= RPM
B	= width	$n_{\text{max}}$	= maximum permissible RPM
BDD	= thickness of shoulder	NAL	= position of hub
BEM	= note	ND	= thickness of hub
BEZ	= description	NH	= zero height
BH	= tipping height	NL	= cutting length
BO	= bore diameter	NLA	= pinhole dimensions
CNC	= Computerized Numerical Control	NT	= grooving depth
d	= diameter	P	= profile
D	= cutting circle diameter	POS	= cutter position
D0	= zero diameter	PT	= profile depth
DA	= outside Diameter	PG	= profile group
DB	= diameter of shoulder	QAL	= cutting material quality
DFC	= Dust Flow Control (optimised chip clearance)	R	= radius
DGL	= number of links	RD	= right hand twist
DIK	= thickness	RH	= right hand rotation
DKN	= double keyway	RP	= radius of cutter
DP	= polycrystalline diamond	S	= shank dimension
DRI	= rotation	SB	= cutting width
FAB	= width of rebate	SET	= set
FAT	= depth of rebate	SLB	= slotting width
FAW	= bevel angle	SLL	= slotting length
FLD	= flange diameter	SLT	= slotting depth
$f_z$	= tooth feed	SP	= tool steel
$f_{z \text{ eff}}$	= effective tooth feed	ST	= Cobalt-basis cast alloys, e.g. Stellite®
GEW	= thread	STO	= shank tolerance
GL	= total length	SW	= cutting angle
GS	= Plunging edge	TD	= diameter of tool body
H	= height	TDI	= thickness of tool
HC	= tungsten carbide, coated	TG	= pitch
HD	= wood thickness (thickness of workpiece)	TK	= reference diameter
HL	= high-alloyed tool steel	UT	= cutting edges with irregular pitch
HS	= high-speed steel (HSS)	V	= number of spurs
HW	= tungsten carbide (TCT)	$v_c$	= cutting speed
ID	= ident number	$v_f$	= feed speed
IV	= insulation glazing	VE	= packing unit
KBZ	= abbreviation	VSB	= adjustment range
KLH	= clamping height	WSS	= workpiece material
KM	= edge breaker	Z	= number of teeth
KN	= single keyway	ZA	= number of fingers
KNL	= combination pinhole consists of 2/7/42 2/9/46,35 2/10/60	ZF	= tooth shape (cutting edge shape)
L	= length	ZL	= finger length
l	= clamping length		
LD	= left hand twist		
LEN	= Leitz standard profiles		

### Notes to the Lexicon concerning the diagrams and tables

The statements made in the diagrams and tables relate to specific conditions and represent parameters from tests subjected to defined conditions. Variations when using tools in individual case due to special application conditions may be possible. Our support team will provide you with detailed information.

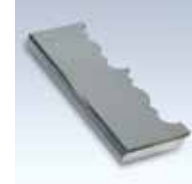

## 8. Knives and spare parts

	8.1. Knives and blank knives	2
	8.1.1 Turnblade knives	2
	8.1.2 Spurs	9
	8.1.3 Grooving knives / profile grooving knives	10
	8.1.4 Edging knives	12
	8.1.5 Planer knives	14
	8.1.6 Blank knives	25
	8.1.7 Profile knives	30
	8.1.8 For portable planers and semi-stationary machines	33
	8.2. Spare parts and clamping parts	34
	8.2.1 For planer / profile cutterheads	34
	8.3. Spacers	35
	<hr/>	
	8.4. Ball bearings and guide rings	40
	<hr/>	
	8.5. Keys	41
	<hr/>	
	8.6. Setting gauges / mounting devices	43
	<hr/>	
	8.7. Jointing stones	46
	<hr/>	
Alphabetical product index		47
<hr/>		
ID index		48

## 8. Knives and spare parts

### 8.1 Knives and blank knives

#### 8.1.1 Turnblade knives

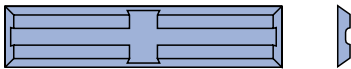

Turnblade knife for router cutter  
WL 100 1

**Workpiece material:**  
Softwood and hardwood

**Cutting material:**  
HW

#### Knife height up to 5.5 mm

##### HW-05

TM 410 0

SB mm	H mm	DIK mm	KBZ	QAL	VE PCS	ID
20	4.1	1.1	WL 100-1	HW-05	10	005186 ●
20	5.5	1.1	WL 100-1	HW-05	10	005187 ●
25	5.5	1.1	WL 100-1	HW-05	10	005188 ●
30	5.5	1.1	WL 100-1	HW-05	10	005189 ●
40	5.5	1.1	WL 100-1	HW-05	10	005190 ●
50	5.5	1.1	WL 100-1	HW-05	10	005191 ●

ID = 1 piece.



Turnblade knife HW

#### Knife height 8 mm

##### HW-30F / HW-05

TM 410 0

SB mm	H mm	DIK mm	VE PCS	ID HW-05	ID HW-30F
7.7	8	1.5	10	005053 ●	005068 ●
9.7	8	1.5	10	005054 ●	005197 ●
11.7	8	1.5	10	005055 ●	005069 ●
14.7	8	1.5	10	005056 ●	005070 ●
19.7	8	1.5	10	005057 ●	005071 ●
25	8	1.5	10	005058 ●	005198 ●
30	8	1.5	10	005059 ●	005072 ●
35	8	1.5	10	005400 ●	005073 ●
40	8	1.5	10	005401 ●	005074 ●
45	8	1.5		007681 ●	007679 □
50	8	1.5	10	005402 ●	005075 ●
60	8	1.5	10	005403 ●	005076 ●
70	8	1.5		007682 ●	007680 □
80	8	1.5	10		005077 ●
80	8	1.5		005404 ●	
100	8	1.5		005405 ●	005184 ●
120	8	1.5		005406 ●	005185 ●

ID = 1 piece.

Cutting material recommendation	HW-30F	HW-05
Softwood	◆	◇
Hardwood	◇	◆
Glulam	◇	◆
Chipboard	◇	◆
MDF	◇	◆
Thermoplastics (PE, PP, PVC, etc.)	◇	◆

◆ suitable ◇ partly suitable

**Cutting material:**  
HW fine grain quality/ HW

## 8. Knives and spare parts

### 8.1 Knives and blank knives

#### 8.1.1 Turnblade knives

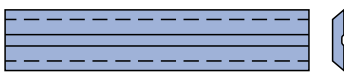

Turnblade knife HW

Cutting material recommendation	HW-30F MC	HW-30F MC Micro
	Softwood	◆
Hardwood	◇	◆
Glulam	◇	◇
Chipboard		
MDF		
Thermoplastics (PE, PP, PVC, etc.)	◇	◇
	HW-05 MC	TDC
Softwood	◇	◇
Hardwood	◆	◇
Glulam	◆	◆
Chipboard	◆	◆
MDF	◆	◆
Thermoplastics (PE, PP, PVC, etc.)	◆	◆
	DC	
Softwood		
Hardwood		◇
Glulam		◇
Chipboard		◆
MDF		◇
Thermoplastics (PE, PP, PVC, etc.)		

◆ suitable ◇ partly suitable

#### Coating:

Marathon MC (Multi Coating) /  
Marathon TDC (Tungsten Diamond  
Coating) / Marathon DC (Diamond  
Coating)

#### Attention:

HW-30F MC cutting edges with  
microfinish for high demands on finish  
quality and cutting performance

### Knife height 8 mm Marathon

#### HW-30F MC / HW-30F MC Micro / HW-05 MC / HW TDC / HW DC

TM 410 0, TM 410 0 50, TM 410 0 70

SB mm	H mm	DIK mm	VE PCS	ID HW-30F MC	ID HW-30F MC Micro	ID HW-05 MC	ID HW TDC	ID HW DC
7.7	8	1.5	1					601400
7.7	8	1.5	10	601600 ●	601704 ●	601628 ●	601416	
9.7	8	1.5	1					601401
9.7	8	1.5	10	601601 ●	601705 ●	601629 ●	601417	
11.7	8	1.5	1					601402
11.7	8	1.5	10	601602 ●	601706 ●	601630 ●	601418	
14.7	8	1.5	1					601403 ●
14.7	8	1.5	10	601603 ●	601707 ●	601631 ●	601419	
19.7	8	1.5	1					601404 ●
19.7	8	1.5	10	601604 ●	601708 ●	601632 ●	601420	
25	8	1.5	1					601405
25	8	1.5	10	601605 ●	601709 ●	601633 ●	601421	
30	8	1.5	1					601406 ●
30	8	1.5	10	601606 ●	601710 ●	601634 ●	601422	
35	8	1.5	1					601407
35	8	1.5	10	601607 ●	601711 ●	601635 ●	601423	
40	8	1.5	1					601408
40	8	1.5	10	601608 ●	601712 ●	601636 ●	601424	
45	8	1.5	1	601609 □	601713 □	601637 ●	601425	601409
50	8	1.5	1		601714 ●			601410
50	8	1.5	10	601610 ●		601638 ●	601426	
60	8	1.5	1		601715 ●			601411
60	8	1.5	10	601611 ●		601639 ●	601427	
70	8	1.5	1	601612 □	601716 □	601640 ●	601428	
80	8	1.5	1		601717 ●	601641 ●		
80	8	1.5	10	601613 ●			601429	
100	8	1.5	1	601614 ●	601718 ●	601642 ●	601430	
120	8	1.5	1	601615 ●	601719 ●	601643 ●	601431	

ID = 1 piece.

## 8. Knives and spare parts

### 8.1 Knives and blank knives

#### 8.1.1 Turnblade knives

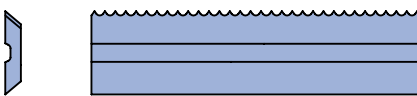

One-way knife HW



**Workpiece material:**

Softwood and hardwood

**Cutting material:**

HW fine grain quality (HW 30F)  
HW (HW-05)

**Coating:**

Marathon MC (Multi Coating)

**RipTec:**

Cutting edges with RipTec profile for high surface quality and cutting performance

### Changeable knife 8 mm Marathon RipTec for turnblade knife tools Integral

**HW-30F MC RipTec**

TM 140 0 08

SB	H	DIK	KBZ	QAL	VE	ID
mm	mm	mm			PCS	
8	8	1.5	EPR 8/8-MC	HW-30F MC	10	601744
10	8	1.5	EPR 8/10-MC	HW-30F MC	10	601745
12	8	1.5	EPR 8/12-MC	HW-30F MC	10	601746
14	8	1.5	EPR 8/15-MC	HW-30F MC	10	601747
20	8	1.5	EPR 8/20-MC	HW-30F MC	10	601748
24	8	1.5	EPR 8/25-MC	HW-30F MC	10	601749
29	8	1.5	EPR 8/30-MC	HW-30F MC	10	601750
34	8	1.5	EPR 8/35-MC	HW-30F MC	10	601751
39	8	1.5	EPR 8/40-MC	HW-30F MC	10	601752
44	8	1.5	EPR 8/45-MC	HW-30F MC		601753
49	8	1.5	EPR 8/50-MC	HW-30F MC	10	601754
59	8	1.5	EPR 8/60-MC	HW-30F MC	10	601755
69	8	1.5	EPR 8/70-MC	HW-30F MC		601756
78	8	1.5	EPR 8/80-MC	HW-30F MC	10	601757
98	8	1.5	EPR 8/100-MC	HW-30F MC		601758
118	8	1.5	EPR 8/120-MC	HW-30F MC		601759

ID = 1 piece.

**HW-05 MC RipTec**

TM 140 0 08

SB	H	DIK	KBZ	QAL	VE	ID
mm	mm	mm			PCS	
8	8	1.5	EPR 8/8B-MC	HW-05 MC	10	601760
10	8	1.5	EPR 8/10B-MC	HW-05 MC	10	601761
12	8	1.5	EPR 8/12B-MC	HW-05 MC	10	601762
14	8	1.5	EPR 8/15B-MC	HW-05 MC	10	601763
20	8	1.5	EPR 8/20B-MC	HW-05 MC	10	601764
24	8	1.5	EPR 8/25B-MC	HW-05 MC	10	601765
29	8	1.5	EPR 8/30B-MC	HW-05 MC	10	601766
34	8	1.5	EPR 8/35B-MC	HW-05 MC	10	601767
39	8	1.5	EPR 8/40B-MC	HW-05 MC	10	601768
44	8	1.5	EPR 8/45B-MC	HW-05 MC		601769
49	8	1.5	EPR 8/50B-MC	HW-05 MC		601770
59	8	1.5	EPR 8/60B-MC	HW-05 MC		601771
69	8	1.5	EPR 8/70B-MC	HW-05 MC		601772
78	8	1.5	EPR 8/80B-MC	HW-05 MC		601773
98	8	1.5	EPR 8/100B-MC	HW-05 MC		601774
118	8	1.5	EPR 8/120B-MC	HW-05 MC		601775

ID = 1 piece.

## 8. Knives and spare parts

### 8.1 Knives and blank knives

#### 8.1.1 Turnblade knives

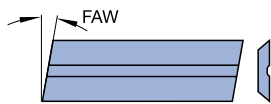

Turnblade knife ZM 10/x

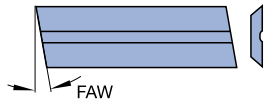

Turnblade knife ZM 11/x

**Workpiece material:**

Softwood and hardwood

**Cutting material:**

HW fine grain quality

#### Knife height 8 mm (bevel/tenoning tools)

**HW-F**

TM 410 0

SB mm	H mm	DIK mm	FAW °	KBZ	QAL	ID
21	8	1.5	10°	ZM 10/1	HW-F	005004 ●
15	8	1.5	14°	ZM 10/4	HW-F	005050 ●
21	8	1.5	10°	ZM 11/1	HW-F	005006 ●
15	8	1.5	14°	ZM 11/4	HW-F	005051 ●

ID = 1 piece.

#### Knife height 8 mm Marathon (bevel/tenoning tools)

**HW-30F MC / HW-05 MC**

TM 410 0 50

SB mm	H mm	DIK mm	FAW °	ID HW-05 MC	ID HW-30F MC
15	8	1.5	8°	601645 ●	601616 ●
15	8	1.5	8°	601644 ●	601617 ●
15	8	1.5	14°	601647 ●	601618 ●
15	8	1.5	14°	601646 ●	601619 ●
21	8	1.5	10°	601649 ●	601620 ●
21	8	1.5	10°	601648 ●	601621 ●

ID = 1 piece.



Turnblade knife ZM 10/x

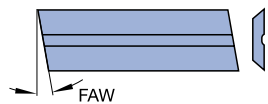

Turnblade knife ZM 11/x

Cutting material recommendation	HW-30F MC	HW-05 MC
Softwood	◆	◇
Hardwood	◇	◆
Glulam	◇	◆
Chipboard		◆
MDF		◆
Thermoplastics (PE, PP, PVC, etc.)	◇	◆

◆ suitable ◇ partly suitable

**Coating:**

Marathon MC (Multi Coating)

## 8. Knives and spare parts

### 8.1 Knives and blank knives

#### 8.1.1 Turnblade knives

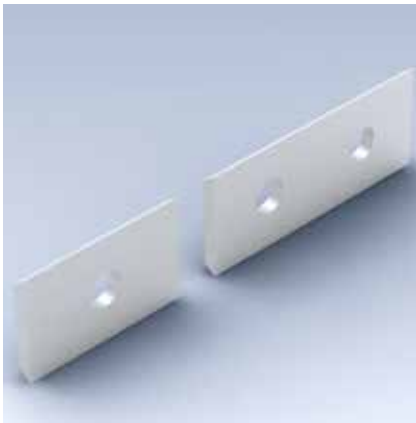

#### Knife height 12 mm

##### HW-05F / HW-02UF

TM 405 0

Knife	SB mm	H mm	DIK mm	VE PCS	ID HW-05F	ID HW-02UF	ID TDC
1	7.6	12	1.5	10	005080 ●		602414
1	9	12	1.5	10	005158 ●		602415
1 *	12	12	1.5	10	005081 ●		602416 ●
1	15	12	1.5	10	005082 ●		602417
1	20	12	1.5	10	005083 ●	602001 ●	602418
2	30	12	1.5	10	005084 ●	602002 ●	602419 ●
2	40	12	1.5	10	005085 ●	602003 ●	602420
2	50	12	1.5	10	005086 ●	602004 ●	602421 ●
2	60	12	1.5	10	005087 ●		602422

ID = 1 piece.

\* = with 4 cutting edges.

Knife type:  
Type 1 Type 2

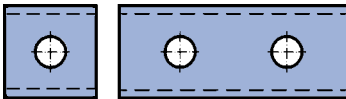

Turnblade knife

Cutting material recommendation	HW-05F	HW-02 UF
Softwood	◆	◇
Hardwood	◇	◆
Glulam	◇	◆
Chipboard	◇	◆
MDF	◇	◆
Thermoplastics (PE, PP, PVC, etc.)	◇	◆

◆ suitable ◇ partly suitable

**Cutting material:**

HW / HW ultra fine grain quality

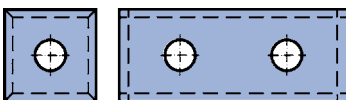

Turnblade knife with 4 cutting edges

Cutting material recommendation	HW-05F	HW-02 UF
Softwood	◆	◇
Hardwood	◇	◆
Glulam	◇	◆
Chipboard	◇	◆
MDF	◇	◆
Thermoplastics (PE, PP, PVC, etc.)	◇	◆

◆ suitable ◇ partly suitable

**Cutting material:**  
HW / HW ultra fine grain quality

#### Knife height 12 mm with 4 cutting edges

##### HW-05F / HW-02UF

TM 405 0

SB mm	H mm	DIK mm	VE PCS	ID HW-02UF	ID HW-05F
30	12	1.5	10	602005 ●	005161 ●
50	12	1.5	10	602006 ●	006506 ●

ID = 1 piece.

##### HW-05F with 3 holes

TM 405 0

SB mm	H mm	DIK mm	QAL HW-05F	VE PCS	ID
50	12	1.7	HW-05F	10	007668 ●

ID = 1 piece.

**Workpiece material:**

Solid wood, wood derived materials

**Cutting material:**

HW

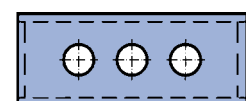

Turnblade knife with 4 cutting edges and 3 holes



## 8. Knives and spare parts

### 8.1 Knives and blank knives

#### 8.1.1 Turnblade knives

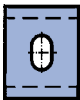

Turnblade knife

**Workpiece material:**

Softwood and hardwood

**Cutting material:**

HW

#### Knife height 12 mm (slotting tools)

**HW**

TM 405 0

SB	H	DIK	KBZ	QAL	ID
mm	mm	mm			
7.6	12	1.5	SM 1/1	HW	005120 ●
9.6	12	1.5	SM 1/2	HW	005121 ●
11.6	12	1.5	SM 1/3	HW	005122 ●

Knife type:

Type 1

Type 2

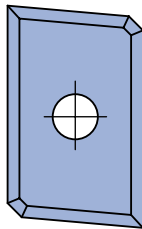
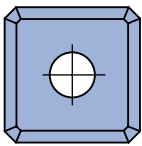

Turnblade knife

#### Knife height 12 mm with bevel

**HW**

TM 405 0

Knife	SB	H	DIK	FAW	QAL	ID
	mm	mm	mm	°		
1	12	12	1.5	1x45°	HW	602009 ●
2	19.7	12	1.5	5°	HW	602010 ●

**Workpiece material:**

Softwood and hardwood

**Cutting material:**

HW

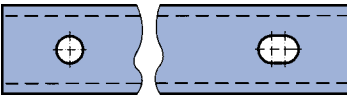

Turnblade knife

**Workpiece material:**

Softwood and hardwood

**Cutting material:**

HW

#### Knife height 13 mm

**HW**

TM 405 0

SB	H	DIK	QAL	VE	ID
mm	mm	mm		PCS	
80	13	2.2	HW	10	005096 ●
100	13	2.2	HW	10	005097 ●
120	13	2.2	HW	10	005098 ●

ID = 1 piece.

## 8. Knives and spare parts

### 8.1 Knives and blank knives

#### 8.1.1 Turnblade knives

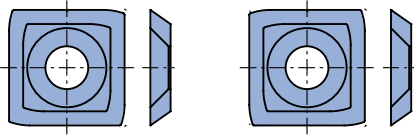

#### Turnblade knife with radius for calibration moulder System Rotoles

##### HW

TM 435 0

SB	H	DIK	QAL	VE	ID	ID
mm	mm	mm		PCS	left	right
14.3	14.3	2.5	HW	10	602525 ●	602526 ●
14	14	2	HW-10F	10	602527 ●	602528 ●

##### Workpiece material:

Softwood and hardwood

##### Cutting material:

HW / HW fine grain quality

ID = 1 piece.

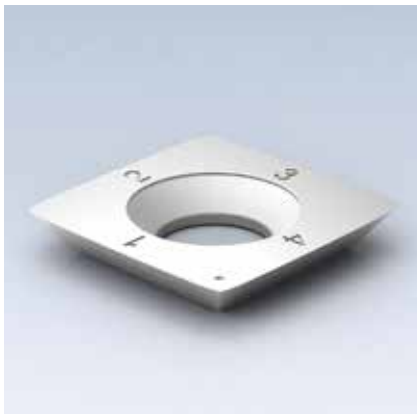

#### Turnblade knives for cutterhead system HeliCut

##### HW / TDC

TM 135 0, TM 405 0, TM 435 0

BEM	SB	H	DIK	QAL	VE	ID
	mm	mm	mm		PCS	
HeliCut 15	15	15	2.5	HW	10	009549 ●
HeliCut 15	15	15	2.5	HW-MF	10	009543 ●
HeliCut 15	15	15	2.5	TDC		602900 ●
HeliCut 11 (peripheral tip)	11	11	1.5	HW	10	602515 ●
HeliCut 11 (peripheral tip)	11	11	1.5	TDC		602904 ●
HeliCut 11 (plunging tip D30)	20.6	12.7	2	HW	10	602531 ●
HeliCut 11 (plunging tip D40)	22	12.7	2	HW	10	602516 ●

ID = 1 piece.

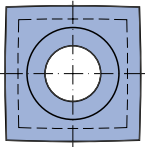

HW turnblade knife

##### Workpiece material:

Softwood and hardwood

##### Cutting material:

HW / TDC

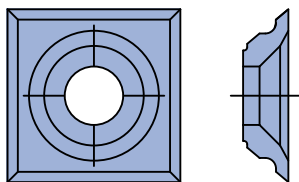

#### Knife height 21 mm with 4 cutting edges

##### HW

TM 410 0

SB	H	DIK	QAL	ID
mm	mm	mm		
21	21	5.5	HW	009527 ●

Turnblade knife with 4 cutting edges

##### Workpiece material:

Softwood and hardwood

##### Cutting material:

HW

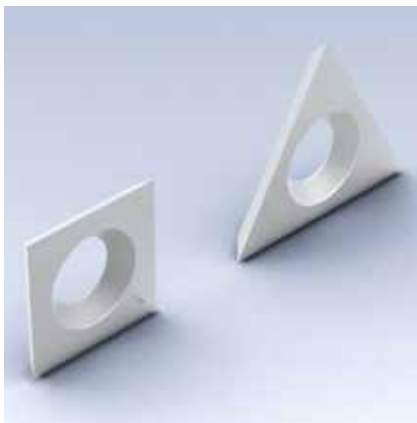

### Spurs

#### HW / DP

TM 405 0, TM 480 0

SB mm	H mm	DIK mm	KBZ	QAL	VE PCS	ID
14	14	2	VS 1	HW-F	10	005099 ●
14	14	1.2	VS 4	HW	10	005130 ●
14	14	1.2	Holz-Her	HW	10	602500 ●
15	15	2		HW		005100 ●
19		2	VS 2	HW-F	10	005115 ●
19		2	VS 2R*	HW-F	10	006615 ●
19		2	VS 2L*	HW-F	10	006616 ●
19		2	VS 2	DP*	2	006607 ●
19		2	VS 3R	HW-F		005116 ●
19		2	VS 3L	HW-F		005159 ●

\* = Spurs with reduced slotting depth. Knives can be used alternatively in VS2 knife seating.

DP\* = diamond coated.

ID = 1 piece.

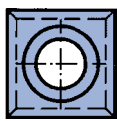

VS 1

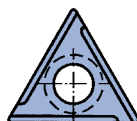

VS 3L

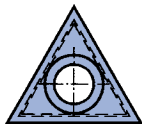

VS 2

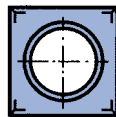

VS 4

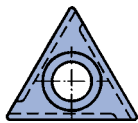

VS 3R

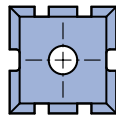

ID 005100

#### Workpiece material:

Solid wood, wood derived materials

#### Cutting material:

HW fine grain quality / DP\*

## 8. Knives and spare parts

### 8.1 Knives and blank knives

#### 8.1.3 Grooving knives / profile grooving knives

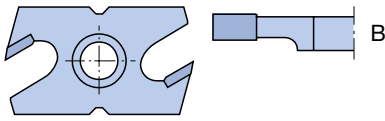

Grooving knife

Grooving knife image

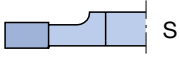

Grooving knife mirror image

**Workpiece material:**

Softwood and hardwood

**Cutting material:**

HW fine grain quality

#### Grooving knives

**Mechanical feed**

TM 460 0

SB mm	KBZ	QAL	ID
3	NA 3B	HW-F	008315 ●
3	NA 3S	HW-F	008316 ●
3	NAK 3B*	HW-F	616002 ●
3	NAK 3S*	HW-F	616003 ●
4.5	NA 4,5	HW-F	008333 ●
4	NA 4	HW-F	008317 ●
5	NA 5	HW-F	008318 ●
7	NA 7	HW-F	008319 ●
8	NAN 8	HW-F	008349 ●
9	NA 9	HW-F	008320 ●

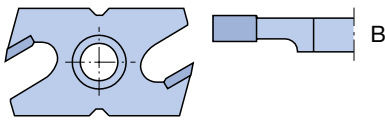

Grooving knife

Grooving knife image



Grooving knife mirror image

**Workpiece material:**

Softwood and hardwood

**Cutting material:**

HW fine grain quality

**Manual feed**

TM 460 1

SB mm	KBZ	QAL	ID
3	NB 3B	HW-F	008321 ●
3	NB 3S	HW-F	008322 ●
3	NBK 3B*	HW-F	616000 ●
3	NBK 3S*	HW-F	616001 ●
4	NB 4	HW-F	008323 ●
5	NB 5	HW-F	008324 ●
7	NB 7	HW-F	008325 ●
8	NBN 8	HW-F	008348 ●
9	NB 9	HW-F	008326 ●

\* Grooving knife with reduced grooving depth.

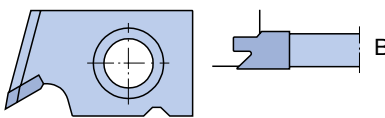

Profile grooving knife

Profile grooving knife image

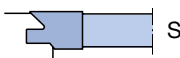

Profile grooving knife mirror image

**Workpiece material:**

Softwood and hardwood

**Cutting material:**

HW fine grain quality

#### Profile grooving knives

**For sealing strip**

TM 160 0

SB mm	KBZ	QAL	ID
8	NC 1B	HW-F	008327 ●
8	NC 1S	HW-F	008328 ●

## 8. Knives and spare parts

### 8.1 Knives and blank knives

#### 8.1.3 Grooving knives / profile grooving knives

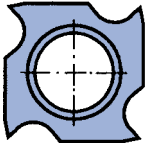

Lamello turnblade knives

**Cutting material:**

HW

#### Lamello turnblade knives

**HW**

TM 463 0

SB	H	DIK	KBZ	QAL	VE	ID
mm	mm	mm			PCS	
18	18	1.95	WP 18/1,95	HW	10	<b>005114 ●</b>
18	18	2.5	WP 18/2,5	HW	10	<b>005195 ●</b>

ID = 1 piece

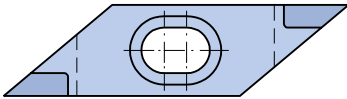

Rhomboid turnblade knives

**Cutting material:**

HW fine grain quality

#### Rhomboid turnblade knives

**HW-F**

TM 461 0

L	H	SB	KBZ	QAL	ID
mm	mm	mm			
45.416	12	5.6	RMA 5,6	HW-F	<b>008329 ●</b>
45.416	12	6.6	RMA 6,6	HW-F	<b>008330 ●</b>

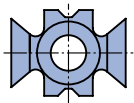

**Workpiece material:**  
Softwood and hardwood

**Cutting material:**  
HW fine grain quality

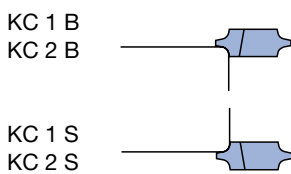

**Workpiece material:**  
Softwood and hardwood

**Cutting material:**  
HW fine grain quality

#### Mechanical feed

##### HW-F

TM 462 0

SB mm	H mm	DIK mm	KBZ	QAL	ID
20	15	8	KM 11/0 45°	HW-F	008268 ●
20	15	7	KM 12/4 R1,5	HW-F	008272 ●
20	15	7.3	KM 12/3 R2	HW-F	008307 ●
22.3	15	9	KM 12/0 R3	HW-F	008270 ●
22	15	9	KM 15/0 R3	HW-F	008275 ●
20	15	9	KM 12/1 R3	HW-F	008271 ●
17.5	15	8	KM 11/1 60°	HW-F	008269 ●
18.3	15	7.3	KM 12/3F R2F	HW-F	008308 ●
22.3	15	10	KM 12/5 R3F	HW-F	008273 ●
22.3	15	7.3	KM 13/0 N5	HW-F	008274 ●
22.3	15	9	KM 13/1 N7	HW-F	008287 ●
22.3	15	7.3	KM 16/0	HW-F	008286 ●
22.3	15	7.3	KM 14/0 R5	HW-F	008347 ●

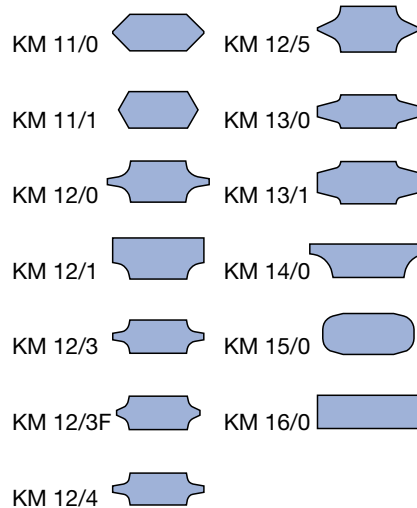

##### HW-F, with bevelled cutting area

TM 462 0

SB mm	H mm	DIK mm	KBZ	QAL	ID
20	15	8.3	KC 1B (R2)	HW-F	008334 ●
20	15	10	KC 2B (R3)	HW-F	008335 ●
20	15	8.3	KC 1S (R2)	HW-F	008336 ●
20	15	10	KC 2S (R3)	HW-F	008337 ●

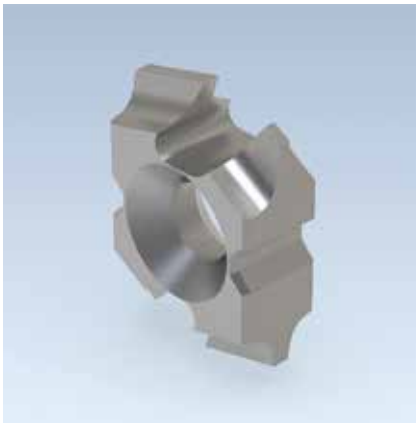

#### Manual feed

##### HW-F

TM 462 1

SB	H	DIK	KBZ	QAL	ID
mm	mm	mm			
23	15	7.3	KM 22/3 R2	HW-F	008309 ●
23	15	8	KM 21/0 45°	HW-F	008292 ●
23	15	9	KM 22/1 R3	HW-F	008290 ●
25.7	15	7.3	KM 24/0 R5	HW-F	008305 ●
23	15	7	KM 22/4 R1,5	HW-F	008295 ●
23	15	9	KM 25/0 R3	HW-F	008291 ●
25.7	15	9.3	KM 23/1 N7	HW-F	008298 ●
25.7	15	7.3	KM 24/1 R5	HW-F	008306 ●
23	15	9	KM 22/0 R3	HW-F	008293 ●
20.5	15	8	KM 21/1 60°	HW-F	008294 ●
21	15	7.3	KM 22/3F R2F	HW-F	008310 ●
23	15	9	KM 22/5 R3F	HW-F	008296 ●
25.7	15	7.3	KM 23/0 N5	HW-F	008297 ●
25.7	15	7.3	KM 26/0	HW-F	008299 ●

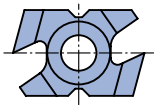

##### Workpiece material:

Softwood and hardwood

##### Cutting material:

HW fine grain quality

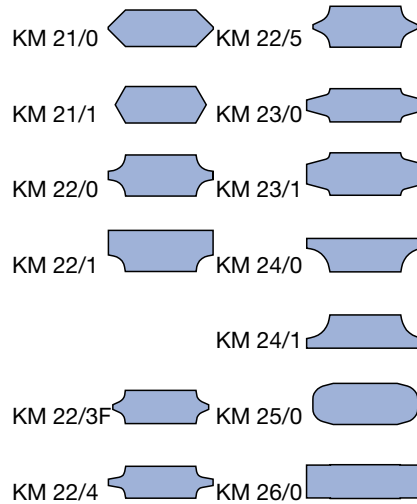



#### Knife height 30 mm

##### For planerhead wedge-type system WM 200 2 05

TM 100 0, TM 100 0 03, TM 100 0 05

SB	H	DIK	VE	ID	ID	ID	ID
mm	mm	mm	PCS	HS Classic	HS Premium	MC33	HW
60	30	3	2	605000	027101 ●	606700 ●	027277 ●
80	30	3	2	605001	027102 ●	606701 ●	027278 ●
100	30	3	2	605002 ●	027103 ●	606702 ●	027279 ●
110	30	3	2	605003	027104 ●	606703 ●	027280 ●
120	30	3	2	605004	027105 ●	606704 ●	027281 ●
130	30	3	2	605005 ●	027106 ●	606705 ●	027282 ●
150	30	3	2	605006 ●	027107 ●	606706 ●	027283 ●
160	30	3	2	605045 ●	027163 ●	606745 ●	
170	30	3	2	605007 ●	027108 ●	606707 ●	027284 ●
180	30	3	2	605008 ●	027109 ●	606708 ●	027285 ●
190	30	3	2	605009	027144 ●	606709 ●	027322 ●
210	30	3	2	605010	027110 ●	606710 ●	027286 ●
230	30	3	2	605011 ●	027111 ●	606711 ●	027287 ●
240	30	3	2	605012 ●	027134 ●	606712 ●	027323 ●
250	30	3	2	605013	027161 ●	606713 ●	
260	30	3	2	605014 ●	027112 ●	606714 ●	027288 ●
270	30	3	2	605015	027162 ●	606715 ●	
310	30	3	2	605016 ●	027113 ●	606716 ●	027289 ●
320	30	3	2	605046	027164 ●	606746 ●	
360	30	3	2	605029	027114 ●	606729 ●	027292 ●
400	30	3	2	605030	027115 ●	606730 ●	
410	30	3	2	605031 ●	027116 ●	606731 ●	027293 ●
460	30	3	2	605032	027130 ●	606732 □	027295 ●
500	30	3	2	605033	027117 ●	606733 □	
510	30	3	2	605034 ●	027118 ●	606734 □	027296 ●
600	30	3	2	605035	027119 ●	606735 □	
610	30	3	2	605036 ●	027120 ●	606736 □	027297 ●
630	30	3	2	605037	027125 ●	606737 □	027298 ●
640	30	3	2	605038 ●	027121 ●	606738 □	027299 ●
710	30	3	2	605039	027122 ●	606739 □	027300 ●
810	30	3	2	605040 ●	027123 ●	606740 □	027302 ●

Cutting material recommendation	HS Classic / Premium	MC33	HW
Solid wood dry	◆	◆	◇
Solid wood wet	◇	◆	
Hardwood dry	◇	◆	◆
Hardwood wet	◇	◆	
Glulam		◇	◇
Thermoplastics (PE, PP, PVC, etc.)	◆	◆	◇
WPC (Wood-Plastic-Composite)	◇	◆	◇

◆ suitable ◇ partly suitable



Cross section of planer knife (HS Classic / HS Premium / MC33)



Cross section of planer knife (HW)

##### Cutting material:

HS Classic / HS Premium / MC33 / HW

##### Wedge angle:

40° (HS Classic / HS Premium / MC33)

45° (HW)

ID = 1 piece.

#### Knife height 35 mm

##### For long planerheads wedge-type system

TM 100 0, TM 100 0 03, TM 100 0 05

SB	H	DIK	VE	ID	ID	ID	ID
mm	mm	mm	PCS	HS Classic	HS Premium	MC33	HW
60	35	3	2	605119	027387 ●	606819 ●	
100	35	3	2	605120	027388 ●	606820 ●	
160	35	3	2	605121	027389 ●	606821 ●	
230	35	3	2	605122	027390 ●	606822 ●	
310	35	3	2	605100	027351 ●	606800 ●	027303 ●
320	35	3	2	605101	027352 ●	606801 ●	027304 □
330	35	3	2	605102	027353 ●	606802 ●	027305 □
360	35	3	2	605103	027354 ●	606803 ●	027306 □
400	35	3	2	605104	027355 ●	606804 ●	027307 □
410	35	3	2	605105 ●	027356 ●	606805 ●	027308 ●
450	35	3	2	605106	027357 ●	606806 □	027309 □
460	35	3	2	605107	027358 ●	606807 □	027310 □
500	35	3	2	605108 ●	027359 ●	606808 ●	027311 □
510	35	3	2	605109 ●	027360 ●	606809 ●	027312 ●
600	35	3	2	605110	027361 ●	606810 □	027313 □
610	35	3	2	605111 ●	027362 ●	606811 □	027314 □
630	35	3	2	605112	027363 ●	606812 □	027315 □
635	35	3	2	605113	027364 ●	606813 □	027316 ●
640	35	3	2	605114 ●	027365 ●	606814 □	027317 ●
660	35	3	2		027371 ●		
700	35	3	2	605115	027366 ●	606815 □	027318 □
710	35	3	2	605116	027367 ●	606816 □	027319 □
740	35	3	2	605117	027368 ●	606817 □	027320 □
810	35	3	2	605118 ●	027369 ●	606818 □	027321 ●

ID = 1 piece.





### Knives for cassette system

#### Planer knives 30 mm with threaded bore

TM 105 0

SB	H	DIK	VE	ID	ID
mm	mm	mm	PCS	HS	HW
130	30	3	2	006825 ●	006915 ●
150	30	3	2	006928 ●	006931 ●
180	30	3	2	006826 ●	006916 ●
190	30	3	2	006929 ●	
230	30	3	2	006827 ●	006917 ●
240	30	3	2	006926 ●	

ID = 1 piece.

Cutting material recommendation	HS	HW
Solid wood dry	◆	
Solid wood wet	◇	
Hardwood dry		◆
Hardwood wet		◆
Glulam		◆
Chipboard		◇
MDF		◇
Thermoplastics (PE, PP, PVC, etc.)		◇
WPC (Wood-Plastic-Composite)		◇

◆ suitable ◇ partly suitable



Cross section of planer knife (HS Classic / HS Premium / MC33)



Cross section of planer knife (HW)

#### Cutting material:

HS / HW



### Planer knives with 60° back serration

For planerhead with 60° back serrated knife fixture

AT 103 0 29

SB	H	DIK	SET	QAL	ID
mm	mm	mm	PCS		
150	30	5	2	MC33	697359 □
230	30	5	2	MC33	697360 □
310	30	5	2	MC33	697361 □
320	30	5	2	MC33	697362 □
330	30	5	2	MC33	697363 □
40	40	5	2	MC33	697300 ●
60	40	5	2	MC33	697301 ●
80	40	5	2	MC33	697302 ●
100	40	5	2	MC33	697303 ●
130	40	5	2	MC33	697304 ●
150	40	5	2	MC33	697305 ●
170	40	5	2	MC33	697306 ●
180	40	5	2	MC33	697307 ●
190	40	5	2	MC33	697308 ●
210	40	5	2	MC33	697309 ●
230	40	5	2	MC33	697310 ●
240	40	5	2	MC33	697311 ●
270	40	5	2	MC33	697312 ●
310	40	5	2	MC33	697313 ●

Cutting material recommendation	MC 33
Solid wood dry	◆
Solid wood wet	◆
Hardwood dry	◆
Hardwood wet	◆
Glulam	◇
Chipboard	
MDF	
Thermoplastics (PE, PP, PVC, etc.)	◆
WPC (Wood-Plastic-Composite)	◆

◆ suitable ◇ partly suitable

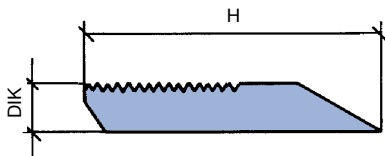

**Cutting material:**  
MC33

Set of the same weight.

**Attention:**

Please do not mix new MC33 blank knives with previous MC blank knives in one cutterhead due to weight difference.



### Planer knives Powerknife System PKS®

For planerhead with 60° back serrated knife fixture

AT 103 0 26, AT 107 0 26

SB mm	H mm	DIK mm	SET PCS	QAL	ID Blank knife set	ID Blank knife set with backing plate
40	40	10	2	HW-30F	696614	697814
60	40	10	2	HW-30F	696615	697815
80	40	10	2	HW-30F	696616	697816
100	40	10	2	HW-30F	696617	697817
130	40	10	2	HW-30F	696618	697818
150	40	10	2	HW-30F	696619	697819
170	40	10	2	HW-30F	696620	697820
180	40	10	2	HW-30F	696621	697821
190	40	10	2	HW-30F	696622	697822
210	40	10	2	HW-30F	696623	697823
230	40	10	2	HW-30F	696624	697824
240	40	10	2	HW-30F	696625	697825
270	40	10	2	HW-30F	696626	697826
310	40	10	2	HW-30F	696627	697827
40	40	10	2	HW-10F	696600	697800
60	40	10	2	HW-10F	696601	697801
80	40	10	2	HW-10F	696602	697802
100	40	10	2	HW-10F	696603	697803
130	40	10	2	HW-10F	696604	697804
150	40	10	2	HW-10F	696605	697805
170	40	10	2	HW-10F	696606	697806
180	40	10	2	HW-10F	696607	697807
190	40	10	2	HW-10F	696608	697808
210	40	10	2	HW-10F	696609	697809
230	40	10	2	HW-10F	696610	697810
240	40	10	2	HW-10F	696611	697811
270	40	10	2	HW-10F	696612	697812
310	40	10	2	HW-10F	696613	697813

Cutting material recommendation	HW-30F jointable	HW-10F not jointable
Solid wood dry	◆	
Solid wood wet		
Hardwood dry	◆	◆
Hardwood wet		◇
Glulam	◇	◆
Chipboard		◆
MDF	◆	◆
Thermoplastics (PE, PP, PVC, etc.)	◆	◆
WPC (Wood-Plastic-Composite)	◆	◆

◆ suitable ◇ partly suitable

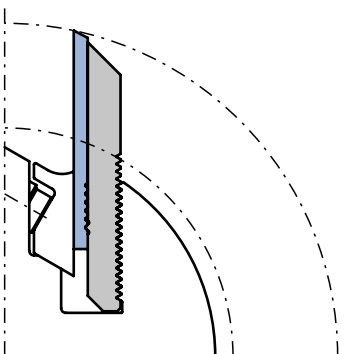
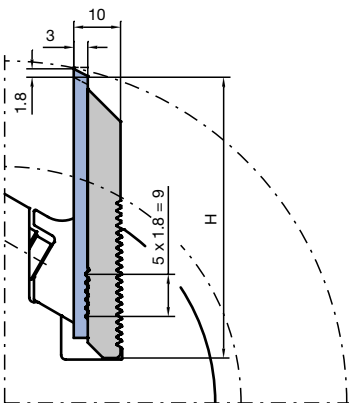

- Blank knives with polished cutting face for high cutting edge quality.
- Solid tungsten carbide - profile knives, adjustable (1.80 mm steps).
- Knives supported by profiled backing plates.
- Resharpening area 10.8 mm at maximum profile depth.

Set of the same weight.

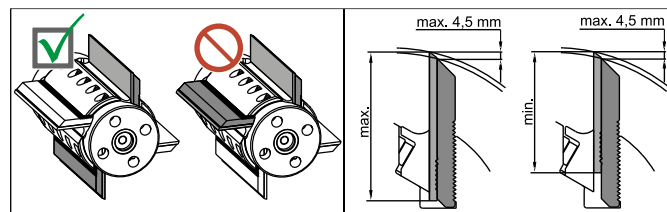

**Cutting material:**  
HW-30F / HW-10F

**Attention:**  
Maximum knife protrusion above the backing plate 4.5 mm. For safety reasons, only mount knives and backing plates of same weight in opposite seatings.

## 8. Knives and spare parts

### 8.1 Knives and blank knives

#### 8.1.5 Planer knives

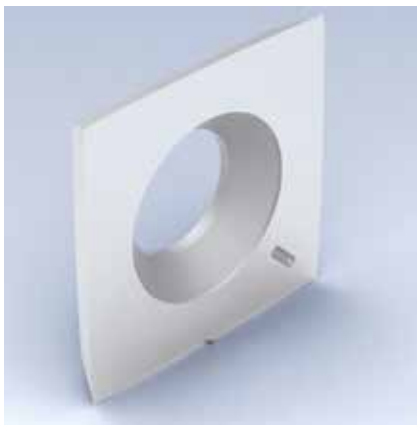

#### Turnblade planing knives HeliPlan

For cutterhead system HeliPlan

TM 405 0

BEZ	ABM mm	QAL	VE PCS	ID
Turnblade knife	15x15x2.5	HW	10	<b>009535 ●</b>
Turnblade knife	15x15x2.5	TDC		<b>602901 ●</b>

ID = 1 piece.

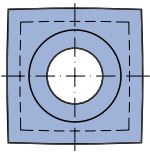

HW turnblade knife

**Workpiece material:**

Softwood and hardwood

**Cutting material:**

HW / TDC

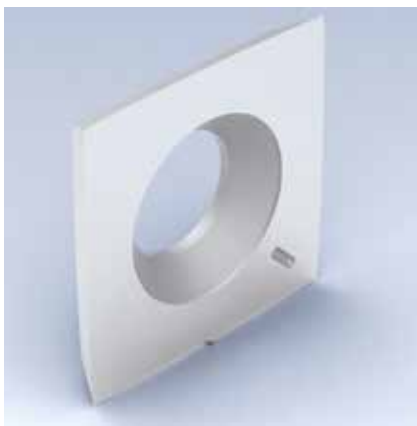

#### Turnblade planing knives CASTOR

For cutterhead system CASTOR-Finish

TM 405 0

BEZ	ABM mm	QAL	VE PCS	ID
Turnblade knife	15x15x2.5	HW	10	<b>009540 ●</b>

ID = 1 piece.

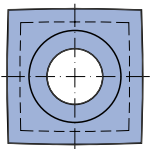

HW turnblade knife

**Workpiece material:**

Softwood and hardwood

**Cutting material:**

HW



**Turnblade planing knives CentroStar, CentroFix, QuickFix**

For cutterhead system CentroStar, CentroFix, QuickFix - HS

AT 103 0 02, AT 103 0 20

SB	H	DIK	SET	QAL	ID
mm	mm	mm	PCS		
100	12	2.7	4	HS	610203 ●
120	12	2.7	4	HS	610204 ●
124.6	12	2.7	4	HS	610244 ●
130	12	2.7	4	HS	610205 ●
136	12	2.7	4	HS	610206 ●
150	12	2.7	4	HS	610208 ●
166	12	2.7	4	HS	610286 ●
170	12	2.7	4	HS	610210 ●
180	12	2.7	4	HS	610211 ●
186	12	2.7	3	HS	610247 ●
190	12	2.7	4	HS	610212 ●
210	12	2.7	4	HS	610213 ●
230	12	2.7	4	HS	610214 ●
236	12	2.7	4	HS	610287 ●
240	12	2.7	4	HS	610215 ●
256	12	2.7	4	HS	610288 ●
260	12	2.7	4	HS	610017 ●
310	12	2.7	4	HS	610018 ●
400	12	2.7	4	HS	610022 ●
410	12	2.7	4	HS	610023 ●
410	12	2.7	3	HS	610043 ●
420	12	2.7	4	HS	610024 ●
430	12	2.7	4	HS	610025 ●
500	12	2.7	4	HS	610028 ●
510	12	2.7	4	HS	610029 ●
520	12	2.7	4	HS	610030 ●
530	12	2.7	4	HS	610031 ●
540	12	2.7	4	HS	610032 ●
610	12	2.7	4	HS	610034 ●
630	12	2.7	4	HS	610036 ●
640	12	2.7	4	HS	610038 ●
710	12	2.7	4	HS	610040 ●
810	12	2.7	4	HS	610042 ●

Cutting material recommendation	HS	MC	HW
Solid wood dry	◆	◆	
Solid wood wet	◇	◆	
Hardwood dry		◇	◆
Hardwood wet		◆	◆
Glulam		◆	◆
Clipboard			◇
MDF			◇

◆ suitable ◇ partly suitable

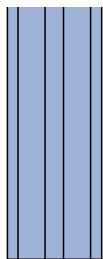

Turnblade knife CentroFix

**Cutting material:**  
HS

## 8. Knives and spare parts

### 8.1 Knives and blank knives

#### 8.1.5 Planer knives



For cutterhead system CentroStar, CentroFix, QuickFix - MC  
AT 103 0 20

SB	H	DIK	SET	QAL	ID
mm	mm	mm	PCS		
100	12	2.7	4	MC	610278 ●
120	12	2.7	4	MC	610279
130	12	2.7	4	MC	610280 ●
150	12	2.7	4	MC	610281
180	12	2.7	4	MC	610282 ●
230	12	2.7	4	MC	610283 ●
240	12	2.7	4	MC	610284 ●
310	12	2.7	4	MC	610285

Cutting material recommendation	HS	MC	HW
Solid wood dry	◆	◆	
Solid wood wet	◇	◆	
Hardwood dry		◇	◆
Hardwood wet		◆	◆
Glulam		◆	◆
Clipboard			◇
MDF			◇

◆ suitable ◇ partly suitable

#### Cutting material:

MC

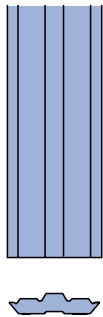

Turnblade knife CentroFix

#### Cutting material:

HW-F

For cutterhead system CentroStar, CentroFix, QuickFix - HW-F  
AT 103 0 20, TM 410 0 02

SB	H	DIK	SET	QAL	ID
mm	mm	mm	PCS		
100	12	2.7	2	HW-F	610606 ●
120	12	2.7	2	HW-F	610610 ●
130	12	2.7	2	HW-F	610612 ●
136	12	2.7	2	HW-F	610614 ●
150	12	2.7	2	HW-F	610616 ●
166	12	2.7	2	HW-F	610680 ●
170	12	2.7	2	HW-F	610620 ●
180	12	2.7	2	HW-F	610621 ●
190	12	2.7	2	HW-F	610625 ●
210	12	2.7	2	HW-F	610627 ●
230	12	2.7	2	HW-F	610629 ●
236	12	2.7	2	HW-F	610679 ●
240	12	2.7	2	HW-F	610631 ●
256	12	2.7	2	HW-F	610681
400	12	2.7	1	HW-F	612016 ●
410	12	2.7	1	HW-F	612017 ●
420	12	2.7	1	HW-F	612018 ●
430	12	2.7	1	HW-F	612019 ●
500	12	2.7	1	HW-F	612022 ●
510	12	2.7	1	HW-F	612023 ●
520	12	2.7	1	HW-F	612024 ●
530	12	2.7	1	HW-F	612025 ●
540	12	2.7	1	HW-F	612026 ●

## 8. Knives and spare parts

### 8.1 Knives and blank knives

#### 8.1.5 Planer knives



Cutting material recommendation	HS	HW
Solid wood dry	◆	
Solid wood wet	◇	
Hardwood dry		◆
Hardwood wet		◆
Glulam		◆
Clipboard		◇
MDF		◇

◆ suitable ◇ partly suitable

**Cutting material:**  
HS / HW

**Cutting material:**  
HW

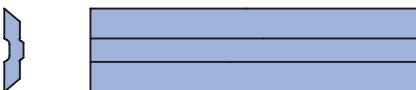

Turnblade knife VariPlan HS / HW  
resharpenable, for finish cutting of  
softwood and hardwood

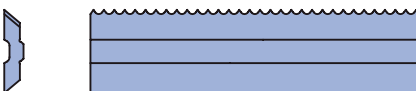

Turnblade knife VariPlan HW Integral  
resharpenable, for pre and finish cutting  
softwood and hardwood

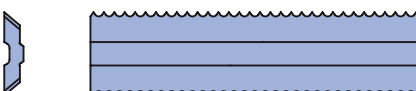

Turnblade knife VariPlan HW RipTec  
resharpenable, for pre-cutting softwood  
and hardwood

### Turnblade planing knives VariPlan / VariPlan Plus

For cutterhead system VariPlan / VariPlan Plus

AT 103 0 03, AT 103 0 27

SB mm	H mm	DIK mm	SET PCS	ID Type HS	ID Type HW Microfinish
50	16	3.7	2	610500 □	617100 □
60	16	3.7	2	610501 □	617101 □
80	16	3.7	2	610502 □	617102 □
100	16	3.7	2	610504 ●	617104 □
120	16	3.7	2	610505 ●	617105 □
130	16	3.7	2	610506 ●	617106 ●
150	16	3.7	2	610509 ●	617109 ●
166	16	3.7	2	610571 □	617171 ●
170	16	3.7	2	610511 ●	617111 ●
180	16	3.7	2	610512 ●	617112 ●
190	16	3.7	2	610514 ●	617114 ●
210	16	3.7	2	610515 ●	617115 ●
230	16	3.7	2	610516 ●	617116 ●
236	16	3.7	2	610569 □	617169 ●
240	16	3.7	2	610518 ●	617118 ●
256	16	3.7	2	610572 □	617172 ●
270	16	3.7	2		617165 ●
310	16	3.7	2	610522 ●	617122 ●
330	16	3.7	2		617124 □
360	16	3.7	2		617125 □
400	16	3.7	2	610526 □	617126 □
410	16	3.7	2	610527 ●	617127 □
410	16	3.7	3	610528 □	
420	16	3.7	2	610529 □	617129 □
430	16	3.7	2	610530 □	617130 □
500	16	3.7	2	610533 ●	617133 □
510	16	3.7	4	610562 □	617162 □
520	16	3.7	4	610563 □	617163 □
530	16	3.7	2	610536 □	617136 □
540	16	3.7	2	610537 □	617137 □
600	16	3.7	2	610538 ●	617138 □
610	16	3.7	2	610539 □	617139 □
630	16	3.7	2	610541 ●	617141 □
640	16	3.7	4	610564 □	617164 □

For cutterhead system VariPlan Plus

AT 103 0 23, AT 103 0 24

SB mm	H mm	DIK mm	SET PCS	ID Type HW	ID Type HW
				Integral	RipTec
100	16	3.7	2	611904	611204 □
120	16	3.7	2	611905	611205 □
130	16	3.7	2	611906 ●	611206 ●
150	16	3.7	2	611909	611209 ●
166	16	3.7	2		611271 ●
170	16	3.7	2	611911 ●	611211 ●
180	16	3.7	2	611912 ●	611212 ●
190	16	3.7	2	611914	611214 ●
210	16	3.7	2	611915	611215 ●
230	16	3.7	2	611916	611216 ●
236	16	3.7	2		611269 ●
240	16	3.7	2	611918 ●	611218 ●
270	16	3.7	2	611965	611265 ●
310	16	3.7	2	611922	611222 ●



Cutting material recommendation	HS	HW
Solid wood dry	◆	
Solid wood wet	◇	
Hardwood dry		◆
Hardwood wet		◆
Glulam		◆
Clipboard		◇
MDF		◇

◆ suitable ◇ partly suitable

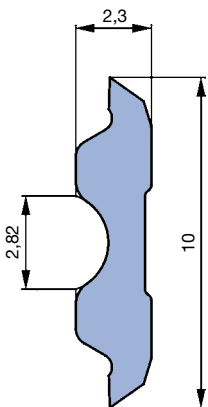

Turnblade knife MicroTec  
Turnblade knife TriTec

#### Workpiece material:

Softwood and hardwood

#### Cutting material:

HS

Suitable for:

#### Long planerheads

on surface planers and thickness planing machines with centrifugal force clamping system (e.g. SCM, SAC, Panhans, Martin)

#### Cutterheads

with centrifugal force clamping system for 4-sided moulders (e.g. Weinig, SCM, Leadermac)

### Turnblade planing knives TriTec

For cutterhead system Tersa, HS

AT 103 0 12

SB	H	DIK	QAL	SET	ID
mm	mm	mm		PCS	
60	10	2.3	HS	4	610900 □
80	10	2.3	HS	4	610901 □
100	10	2.3	HS	4	610902 ●
110	10	2.3	HS	4	610903 ●
120	10	2.3	HS	4	610904 ●
130	10	2.3	HS	4	610905 ●
140	10	2.3	HS	4	610906 ●
150	10	2.3	HS	4	610907 ●
170	10	2.3	HS	4	610908 ●
180	10	2.3	HS	4	610909 ●
190	10	2.3	HS	4	610910 ●
200	10	2.3	HS	4	610911 ●
210	10	2.3	HS	4	610912 ●
220	10	2.3	HS	4	610913 ●
230	10	2.3	HS	4	610914 ●
240	10	2.3	HS	4	610915 ●
250	10	2.3	HS	4	610916 ●
260	10	2.3	HS	4	610917 ●
265	10	2.3	HS	4	610918 ●
270	10	2.3	HS	4	610919 ●
300	10	2.3	HS	4	610920 ●
310	10	2.3	HS	4	610921 ●
350	10	2.3	HS	4	610922 ●
360	10	2.3	HS	4	610923 □
400	10	2.3	HS	4	610924 ●
410	10	2.3	HS	4	610925 ●
420	10	2.3	HS	4	610926 □
430	10	2.3	HS	4	610927 ●
450	10	2.3	HS	4	610928 □
460	10	2.3	HS	4	610929 □
500	10	2.3	HS	4	610930 ●
510	10	2.3	HS	4	610931 ●
520	10	2.3	HS	4	610932 ●
530	10	2.3	HS	4	610933 ●
600	10	2.3	HS	4	610934 □
610	10	2.3	HS	4	610935 ●
630	10	2.3	HS	4	610936 ●
640	10	2.3	HS	4	610937 ●
660	10	2.3	HS	4	610938 ●
710	10	2.3	HS	4	610939 ●
740	10	2.3	HS	4	610940 □
810	10	2.3	HS	4	610941 ●

Further dimensions on request.





#### Turnblade planing knives MicroTec

For cutterhead system Tersa, HW

AT 103 0 12

SB	H	DIK	QAL	SET	ID
mm	mm	mm		PCS	
60	10	2.3	HW	2	610950 □
80	10	2.3	HW	2	610951 □
100	10	2.3	HW	2	610952 □
110	10	2.3	HW	2	610953 □
120	10	2.3	HW	2	610954 □
130	10	2.3	HW	2	610955 □
140	10	2.3	HW	2	610956 □
150	10	2.3	HW	2	610957 □
170	10	2.3	HW	2	610958 □
180	10	2.3	HW	2	610959 □
190	10	2.3	HW	2	610960 □
200	10	2.3	HW	2	610961 □
210	10	2.3	HW	2	610962 □
220	10	2.3	HW	2	610963 □
230	10	2.3	HW	2	610964 □
240	10	2.3	HW	2	610965 □
250	10	2.3	HW	2	610966 □
260	10	2.3	HW	2	610967 □
265	10	2.3	HW	2	610968 □
270	10	2.3	HW	2	610969 □
300	10	2.3	HW	2	610970 □
310	10	2.3	HW	2	610971 □
350	10	2.3	HW	2	610972 □
360	10	2.3	HW	2	610973 □
400	10	2.3	HW	2	610974 □
410	10	2.3	HW	2	610975 □
420	10	2.3	HW	2	610976 □
430	10	2.3	HW	2	610977 □
450	10	2.3	HW	2	610978 □
460	10	2.3	HW	2	610979 □
500	10	2.3	HW	2	610980 □
510	10	2.3	HW	2	610981 □
520	10	2.3	HW	2	610982 □
530	10	2.3	HW	2	610983 □

Cutting material recommendation	HS	HW
Solid wood dry	◆	
Solid wood wet	◇	
Hardwood dry		◆
Hardwood wet		◆
Glulam		◆
Clipboard		◇
MDF		◇

◆ suitable ◇ partly suitable

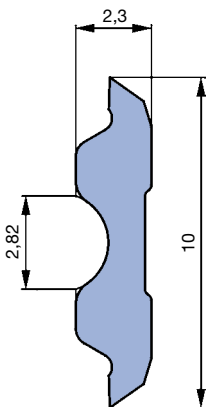

Turnblade knife MicroTec  
Turnblade knife TriTec

#### Cutting material:

HW

#### Note:

Knives longer than 540 mm are cut into pieces.

Suitable for:

#### Long planerheads

on surface planers and thickness planing machines with centrifugal force clamping system (e.g. SCM, SAC, Panhans, Martin)

#### Cutterheads

with centrifugal force clamping system for 4-sided moulders (e.g. Weinig, SCM, Leadermac)

Further dimensions on request.



### Turnblade planing knives Centrolock

For cutterhead system Centrolock / Easylock

AT 103 0 13

SB	H	DIK	SET	ID	ID	ID
mm	mm	mm	PCS	HS	HW	MC
60	16	3	2	611801 ●	611861 ●	611831 ●
80	16	3	2	611802 ●	611862 ●	611832 ●
100	16	3	2	611803 ●	611863 ●	611833 ●
130	16	3	2	611804 ●	611864 ●	611834 ●
150	16	3	2	611805 ●	611865 ●	611835 ●
170	16	3	2	611806 ●	611866 ●	611836 ●
180	16	3	2	611807 ●	611867 ●	611837 ●
190	16	3	2	611808 ●	611868 ●	611838 ●
230	16	3	2	611809 ●	611869 ●	611839 ●
240	16	3	2	611810 ●	611870 ●	611840 ●
260	16	3	2	611811 ●	611871 ●	611841 ●
270	16	3	2	611812 ●	611872 ●	611842 ●
285	16	3	2	611817 ●	611877 ●	611847 ●
310	16	3	2	611813 ●	611873 ●	611843 ●
460	16	3	2	611814 ●		

Cutting material recommendation	HS	MC	HW
Solid wood dry	◆	◆	
Solid wood wet	◇	◆	
Hardwood dry		◇	◆
Hardwood wet		◆	◆
Glulam		◆	◆
Clipboard			◇
MDF			◇

◆ suitable ◇ partly suitable

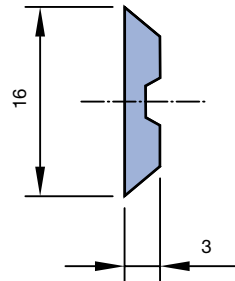

**Cutting material:**

HS / MC / HW



### Spiral planer knife

One-way knife for spiral long planerhead

TM 101 0

BEZ	SB	QAL	ID
	mm		
HS-Spiral knife, one-way	410	HS	006841 ●
HS-Spiral knife, one-way	420	HS	006910
HS-Spiral knife, one-way	510	HS	006842 ●
HS-Spiral knife, one-way	520	HS	006911 ●
HS-Spiral knife, one-way	610	HS	006843 ●
HS-Spiral knife, one-way	630	HS	006912 ●
HS-Spiral knife, one-way	640	HS	006844 ●

Resharpenable knife for spiral long planerhead

TM 106 0

BEZ	SB	QAL	ID
	mm		
HS-Spiral knife, resharpenable	410	HS	006828 ●
HS-Spiral knife, resharpenable	420	HS	006907
HS-Spiral knife, resharpenable	510	HS	006829 ●
HS-Spiral knife, resharpenable	520	HS	006908
HS-Spiral knife, resharpenable	610	HS	006830 ●
HS-Spiral knife, resharpenable	630	HS	006909 ●
HS-Spiral knife, resharpenable	640	HS	006831 ●

**Cutting material:**

HS

## 8. Knives and spare parts

### 8.1 Knives and blank knives

#### 8.1.6 Blank knives



#### Blank knives with 60° back serration

##### HS and MC33 blank knives, for profile and hydro profile cutterheads

AT 103 0 28, AT 103 0 29

SB	H	DIK	PT <sub>max</sub>	SET	ID	ID
mm	mm	mm	mm	PCS	HS	MC33
40	50	8	15	2	697500	697314 ●
60	50	8	15	2	697501	697315 ●
80	50	8	15	2	697502	697316 ●
100	50	8	15	2	697503	697317 ●
130	50	8	15	2	697504	697318 ●
150	50	8	15	2	697505	697319 ●
170	50	8	15	2	697506	697320 ●
180	50	8	15	2	697507	697321 □
190	50	8	15	2	697508	697322 □
210	50	8	15	2	697509	697323 □
230	50	8	15	2	697510	697324 ●
240	50	8	15	2	697511	697325 ●
260	50	8	15	2	697512	697326 □
270	50	8	15	2	697513	697327 □
310	50	8	15	2	697514	697328 ●
40	60	8	20	2	697515	697329 ●
60	60	8	20	2	697516	697330 ●
80	60	8	20	2	697517	697331 ●
100	60	8	20	2	697518	697332 ●
130	60	8	20	2	697519	697333 ●
150	60	8	20	2	697520	697334 ●
170	60	8	20	2	697521	697335 ●
180	60	8	20	2	697522	697336 □
190	60	8	20	2	697523	697337 □
210	60	8	20	2	697524	697338 □
230	60	8	20	2	697525	697339 ●
240	60	8	20	2	697526	697340 ●
260	60	8	20	2	697527	697341 □
270	60	8	20	2	697528	697342 □
310	60	8	20	2	697529	697343 ●
40	70	8	30	2	697530	697344 ●
60	70	8	30	2	697531	697345 ●
80	70	8	30	2	697532	697346 ●
100	70	8	30	2	697533	697347 ●
130	70	8	30	2	697534	697348 ●
150	70	8	30	2	697535	697349 ●
170	70	8	30	2	697536	697350 ●
180	70	8	30	2	697537	697351 ●
190	70	8	30	2	697538	697352 □
210	70	8	30	2	697539	697353 □
230	70	8	30	2	697540	697354 □
240	70	8	30	2	697541	697355 ●
260	70	8	30	2	697542	697356 □
270	70	8	30	2	697543	697357 □
310	70	8	30	2	697544	697358 □

Cutting material recommendation	HS Classic/Premium	MC33	HW
Solid wood dry	◆	◆	◇
Solid wood wet	◇	◆	◆
Hardwood dry	◇	◆	◆
Hardwood wet	◇	◆	◆
Glulam		◇	◇
Thermoplastics (PE, PP, PVC, etc.)	◆	◆	◇
WPC (Wood-Plastic-Composite)	◇	◆	◇

◆ suitable ◇ partly suitable

H	PT
mm	mm
50	15
60	20
70	30

Table to determine maximum profile depth. The profile depth figures are to be regarded as standard values. The maximum profile depth depends on the tool diameter and cutting angle.

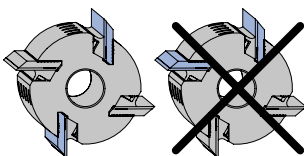
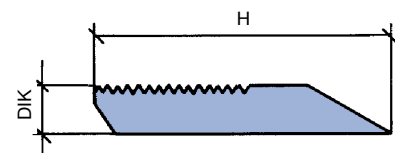

#### Attention:

For safety reasons, always mount knives of the same weight in opposite seatings

#### Cutting material:

HS / MC33

The Leitz MC33 cutting material replaces previous design in MC Marathon

Set of the same weight.

#### Attention:

Please do not mix new MC33 blank knives with previous MC blank knives in one cutterhead due to weight difference.



#### Blank knives with 60° back serration

##### HS and MC33 blank knives for cutting to individual cutting width

TC 110 0, TC 110 0 03

SB	H	DIK	PT <sub>max</sub>	ID	ID
mm	mm	mm	mm	HS	MC33
650	38,1	8	5	635003 □	635206 □
650	45	8	10	635004 □	635207 □
650	50	8	15	635000 ●	635203 □
650	60	8	20	635001 ●	635204 □
650	70	8	30	635002 ●	635205 □

ID = 1 piece.

##### Attention:

Please do not mix new MC33 blank knives with previous MC blank knives in one cutterhead due to weight difference.

Cutting material recommendation	HS	MC 33
Solid wood dry	◆	◆
Solid wood wet	◇	◆
Hardwood dry	◇	◆
Hardwood wet	◇	◆
Glulam		◇
Thermoplastics (PE, PP, PVC, etc.)	◆	◆
WPC (Wood-Plastic-Composite)	◇	◆

◆ suitable ◇ partly suitable

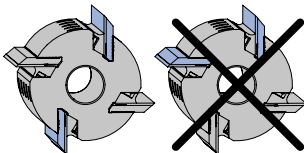
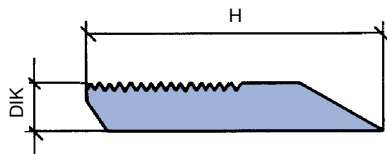

##### Attention:

For safety reasons, always mount knives of the same weight in opposite seatings

##### Cutting material:

HS / MC33



Cutting material recommendation	HW-30F jointable	HW-10F not jointable
Solid wood dry	◆	
Solid wood wet		
Hardwood dry	◆	◆
Hardwood wet		◇
Glulam	◇	◆
Chipboard		◆
MDF	◆	◆
Thermoplastics (PE, PP, PVC, etc.)	◆	◆
WPC (Wood-Plastic-Composite)	◆	◆

◆ suitable ◇ partly suitable

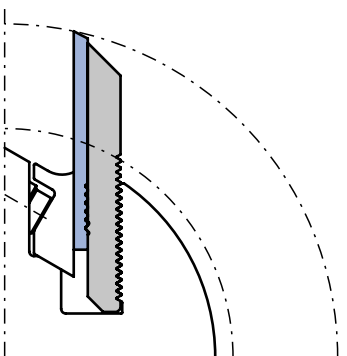
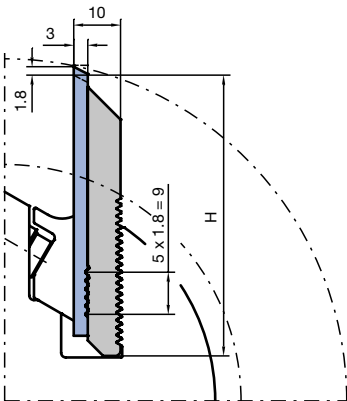

### Blank knives / backing plates Powerknife System PKS®

For profile and hydro profile cutterheads, PT 15 mm

AT 103 0 26, AT 107 0 26

SB mm	H mm	DIK mm	PT <sub>max</sub> mm	SET PCS	QAL	ID Blank knife set	ID Blank knife set with backing plate
40	50	10	15	2	HW-30F	696642 ●	697842 ●
60	50	10	15	2	HW-30F	696643 ●	697843 ●
80	50	10	15	2	HW-30F	696644 ●	697844 ●
100	50	10	15	2	HW-30F	696645 ●	697845 ●
130	50	10	15	2	HW-30F	696646 ●	697846 ●
150	50	10	15	2	HW-30F	696647 ●	697847 ●
170	50	10	15	2	HW-30F	696648 □	697848 □
180	50	10	15	2	HW-30F	696649 □	697849 □
190	50	10	15	2	HW-30F	696650 □	697850 □
210	50	10	15	2	HW-30F	696651 □	697851 □
230	50	10	15	2	HW-30F	696652 □	697852 □
240	50	10	15	2	HW-30F	696653 ●	697853 ●
270	50	10	15	2	HW-30F	696654 □	697854 □
310	50	10	15	2	HW-30F	696655 ●	697855 ●
40	50	10	15	2	HW-10F	696628 ●	697828 ●
60	50	10	15	2	HW-10F	696629 ●	697829 ●
80	50	10	15	2	HW-10F	696630 ●	697830 ●
100	50	10	15	2	HW-10F	696631 ●	697831 ●
130	50	10	15	2	HW-10F	696632 ●	697832 ●
150	50	10	15	2	HW-10F	696633 ●	697833 ●
170	50	10	15	2	HW-10F	696634 □	697834 □
180	50	10	15	2	HW-10F	696635 □	697835 □
190	50	10	15	2	HW-10F	696636 □	697836 □
210	50	10	15	2	HW-10F	696637 □	697837 □
230	50	10	15	2	HW-10F	696638 □	697838 □
240	50	10	15	2	HW-10F	696639 ●	697839 ●
270	50	10	15	2	HW-10F	696640 □	697840 □
310	50	10	15	2	HW-10F	696641 ●	697841 ●

The indicated profile depth values should be regarded as standard values for information. The maximum profile depth depends on the tool diameter and cutting angle.

Set of the same weight.

- Blank knives with polished cutting face for high cutting edge quality.
- Solid tungsten carbide - profile knives, adjustable (1.80 mm steps).
- Knives supported by profiled backing plates.
- Resharpener area 10.8 mm at maximum profile depth.

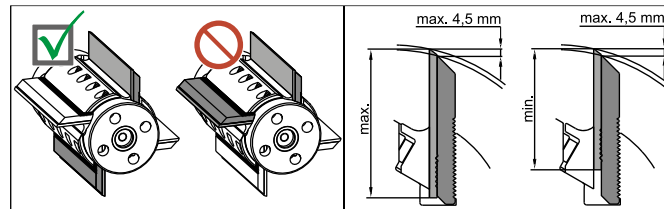

**Cutting material:**  
HW-30F / HW-10F

**Attention:**

Maximum knife protrusion above the backing plate 4.5 mm. For safety reasons, only mount knives and backing plates of same weight in opposite seatings.



### Blank knives / backing plates Powerknife System PKS®

For profile and hydro profile cutterheads, PT 20 mm

AT 103 0 26, AT 107 0 26

SB mm	H mm	DIK mm	PT <sub>max</sub> mm	SET PCS	QAL	ID Blank knife set	ID Blank knife set with backing plate
40	60	10	20	2	HW-30F	696670 ●	697870 ●
60	60	10	20	2	HW-30F	696671 ●	697871 ●
80	60	10	20	2	HW-30F	696672 ●	697872 ●
100	60	10	20	2	HW-30F	696673 ●	697873 ●
130	60	10	20	2	HW-30F	696674 ●	697874 ●
150	60	10	20	2	HW-30F	696675 ●	697875 ●
170	60	10	20	2	HW-30F	696676 □	697876 □
180	60	10	20	2	HW-30F	696677 □	697877 □
190	60	10	20	2	HW-30F	696678 □	697878 □
210	60	10	20	2	HW-30F	696679 □	697879 □
230	60	10	20	2	HW-30F	696680 □	697880 □
240	60	10	20	2	HW-30F	696681 ●	697881 ●
40	60	10	20	2	HW-10F	696656 ●	697856 ●
60	60	10	20	2	HW-10F	696657 ●	697857 ●
80	60	10	20	2	HW-10F	696658 ●	697858 ●
100	60	10	20	2	HW-10F	696659 ●	697859 ●
130	60	10	20	2	HW-10F	696660 ●	697860 ●
150	60	10	20	2	HW-10F	696661 ●	697861 ●
170	60	10	20	2	HW-10F	696662 □	697862 □
180	60	10	20	2	HW-10F	696663 □	697863 □
190	60	10	20	2	HW-10F	696664 □	697864 □
210	60	10	20	2	HW-10F	696665 □	697865 □
230	60	10	20	2	HW-10F	696666 □	697866 □
240	60	10	20	2	HW-10F	696667 ●	697867 ●

Cutting material recommendation	HW-30F jointable	HW-10F not jointable
Solid wood dry	◆	
Solid wood wet		
Hardwood dry	◆	◆
Hardwood wet		◇
Glulam	◇	◆
Chipboard		◆
MDF	◆	◆
Thermoplastics (PE, PP, PVC, etc.)	◆	◆
WPC (Wood-Plastic-Composite)	◆	◆

◆ suitable ◇ partly suitable

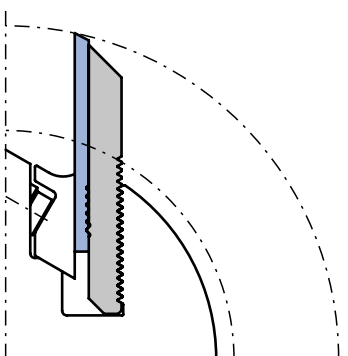
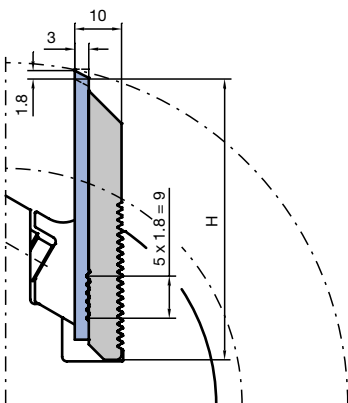

The indicated profile depth values should be regarded as standard values for information. The maximum profile depth depends on the tool diameter and cutting angle.

Set of the same weight.

- Blank knives with polished cutting face for high cutting edge quality.
- Solid tungsten carbide - profile knives, adjustable (1.80 mm steps).
- Knives supported by profiled backing plates.
- Resharpening area 10.8 mm at maximum profile depth.

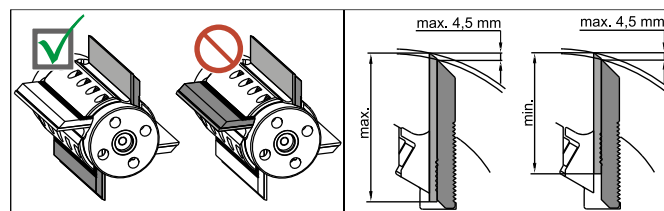

**Cutting material:**

HW-30F / HW-10F

**Attention:**

Maximum knife protrusion above the backing plate 4.5 mm. For safety reasons, only mount knives and backing plates of same weight in opposite seatings.

## 8. Knives and spare parts

### 8.1 Knives and blank knives

#### 8.1.6 Blank knives

Cutting material recommendation	HW-30F jointable	HW-10F not jointable
Solid wood dry	◆	
Solid wood wet		
Hardwood dry	◆	◆
Hardwood wet		◇
Glulam	◇	◆
Chipboard		◆
MDF	◆	◆
Thermoplastics (PE, PP, PVC, etc.)	◆	◆
WPC (Wood-Plastic-Composite)	◆	◆

◆ suitable ◇ partly suitable

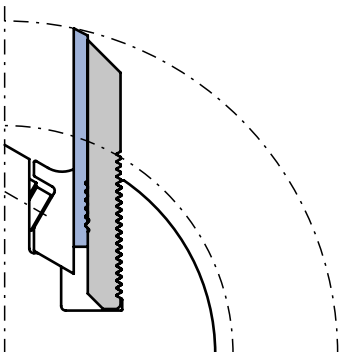
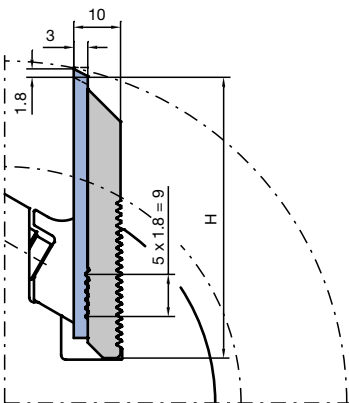

#### For profile and hydro profile cutterheads, PT 30 mm

AT 103 0 26, AT 107 0 26

SB mm	H mm	DIK mm	PT <sub>max</sub> mm	SET PCS	QAL	ID Blank knife set	ID Blank knife set with backing plate
40	70	10	30	2	HW-30F	696691 ●	697891 ●
60	70	10	30	2	HW-30F	696692 ●	697892 ●
80	70	10	30	2	HW-30F	696693 ●	697893 ●
100	70	10	30	2	HW-30F	696694 ●	697894 ●
130	70	10	30	2	HW-30F	696695 ●	697895 ●
150	70	10	30	2	HW-30F	696696 ●	697896 ●
40	70	10	30	2	HW-10F	696684 ●	697884 ●
60	70	10	30	2	HW-10F	696685 ●	697885 ●
80	70	10	30	2	HW-10F	696686 ●	697886 ●
100	70	10	30	2	HW-10F	696687 ●	697887 ●
130	70	10	30	2	HW-10F	696688 ●	697888 ●
150	70	10	30	2	HW-10F	696689 ●	697889 ●

The indicated profile depth values should be regarded as standard values for information. The maximum profile depth depends on the tool diameter and cutting angle.

Set of the same weight.

- Blank knives with polished cutting face for high cutting edge quality.
- Solid tungsten carbide - profile knives, adjustable (1.80 mm steps).
- Knives supported by profiled backing plates.
- Resharpening area 10.8 mm at maximum profile depth.

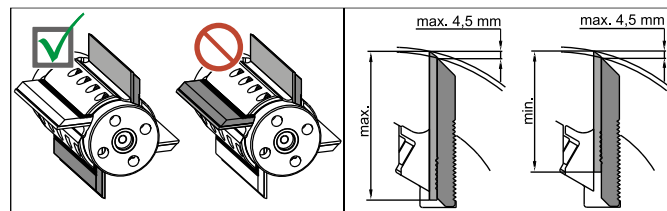

**Cutting material:**  
HW-30F / HW-10F

#### Attention:

Maximum knife protrusion above the backing plate 4.5 mm. For safety reasons, only mount knives and backing plates of same weight in opposite seatings.



**Workpiece material:**  
Softwood

**Cutting material:**  
SP  
For multi-purpose profile cutterheads:  
WM 502 2  
WM 510 1 01  
WM 510 1 02  
Profiles to scale 1:1 can be found on the  
Leitz Homepage [www.leitz.org](http://www.leitz.org)

#### Profile knives for multi-purpose cutterheads

##### Knives

TM 135 1

LEN-Profile	ID
1	026101 ●
3	026103 ●
5	026105 ●
8	026108 ●
9	026109 ●
10	026110 ●
11	026111 ●
12	026112 ●
13	026113 ●
14	026114 ●
15	026115 ●
16	026116 ●
17	026117 ●
18	026118 ●
19	026119 ●
20	026120 ●
21	026121 ●
22	026122 ●
31	026131 ●
34	026134 ●
35	026135 ●
36	026136 ●
39	026177 ●
41	026179 ●
45	026183 ●
47	026185 ●
48	026186 ●
50	026188 ●
55	026193 ●
57	026195 ●
58	026196 ●
66	026254 ●
68	026256 ●
75	026263 ●
76	026264 ●
83	690000 ●
84	690001 ●
91	690003 ●
97	690005 ●
127	690007 ●

##### Limitors

TA 300 1

LEN-Profile	ID
1	026301 ●
3	026303 ●
5	026305 ●
8	026308 ●
9	026309 ●
10	026310 ●
11	026311 ●
12	026312 ●
13	026313 ●
14	026314 ●
15	026315 ●
16	026316 ●
17	026317 ●
18	026318 ●
19	026319 ●
20	026320 ●
21	026321 ●
22	026322 ●
31	026331 ●
34	026334 ●
35	026335 ●
36	026336 ●
39	026384 ●
41	026386 ●
45	026390 ●
47	026392 ●
48	026393 ●
50	026395 ●
55	026400 ●
57	026402 ●
58	026403 ●
66	026411 ●
68	026413 ●
75	026420 ●
76	026421 ●
83	695000 ●
84	695001 ●
91	695003 ●
97	695005 ●
127	695007 ●

Sold in pairs only.



## 8. Knives and spare parts

### 8.1 Knives and blank knives

#### 8.1.7 Profile knives

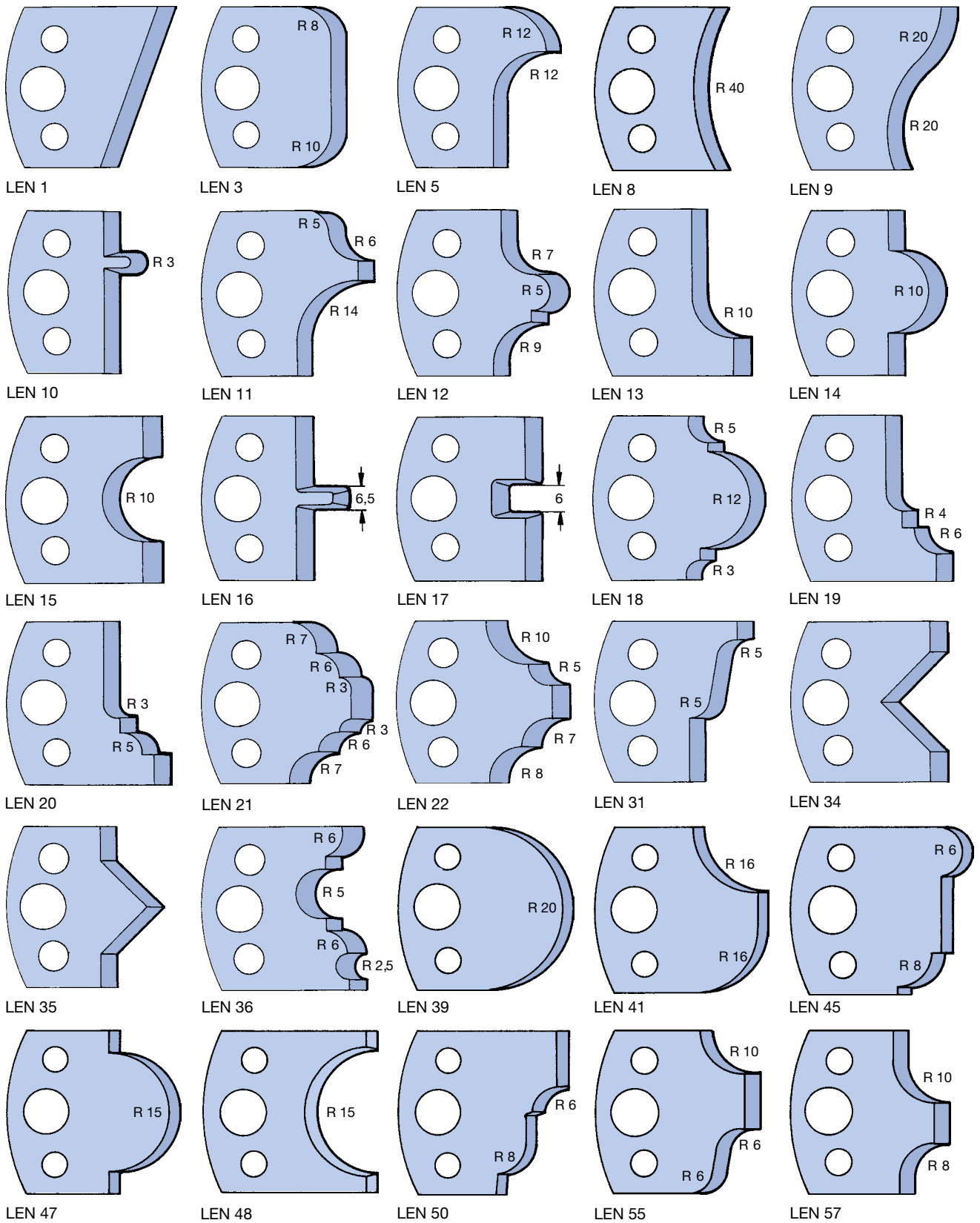

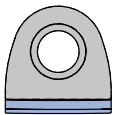
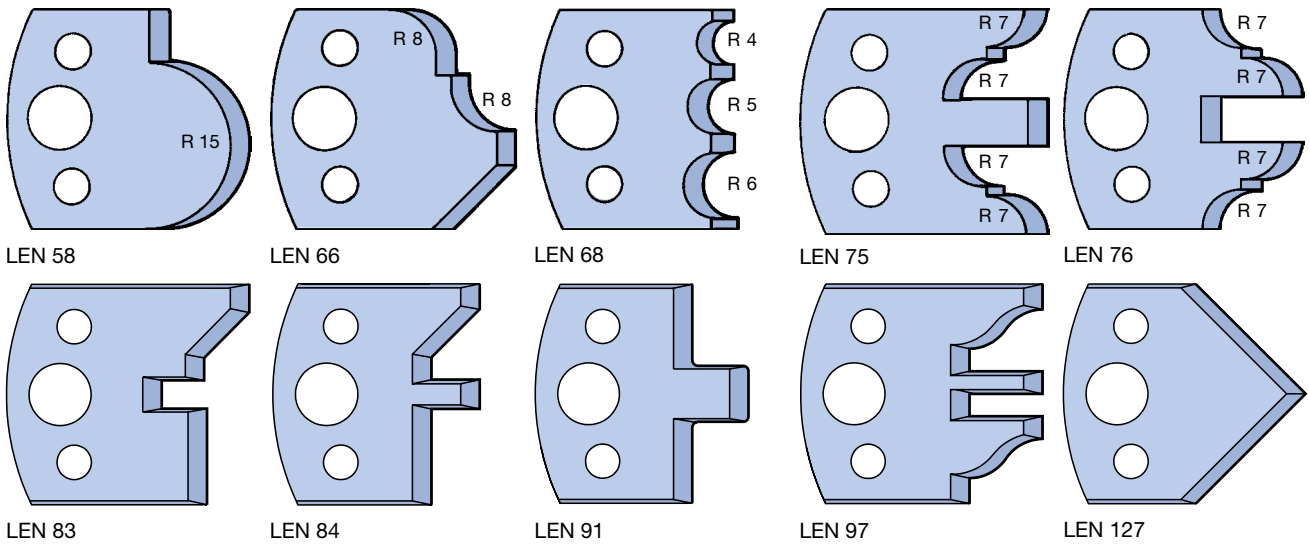

**WhisperCut DP-edges for hybrid tools**

**WhisperCut DP-edges; suitable for the combination with the tool systems ProfilCut, ProFix, turnblade or HeliPlan**

TM 160 0 02, TM 160 0 13

BEM	SB mm	R mm	FAW °	QAL	ID
Jointing	14			DP	<b>091052 ●</b>
Jointing of glued joint*	14			DP	<b>091056 ●</b>
Radius on bottom	14	1.0		DP	<b>091057</b>
Radius on top	14	1.0		DP	<b>091058</b>
Radius on bottom	14	1.5		DP	<b>091059</b>
Radius on top	14	1.5		DP	<b>091060</b>
Radius on bottom	14	2.0		DP	<b>091061</b>
Radius on top	14	2.0		DP	<b>091062</b>
Bevel on bottom	14		45	DP	<b>091063</b>
Bevel on top	14		45	DP	<b>091064</b>

\* = If the knife mounted has a 0° cutting area bevel, it can be used **preferably for glued joints** due to the crown.

## 8. Knives and spare parts

### 8.1 Knives and blank knives

#### 8.1.8 For portable planers and semi-stationary machines

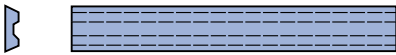

Turnblade knife

**Workpiece material:**

Softwood and hardwood, chipboard and fibre materials, glulam

**Cutting material:**

HW

#### Planer knives for portable planers

**Turnblade knives HW**

TM 410 0

Machine	SB mm	H mm	DIK mm	QAL	ID
AEG, Bosch, Festool, Haffner, Holz-Her, Mafell, Metabo, Scheer	75.5	5.5	1.1	HW	<b>005064 ●</b>
Elu	80.5	5.9	1.2	HW	<b>005131 ●</b>
AEG, Black & Decker, DeWalt, Elu, Mafell, Makita, Metabo	82	5.5	1.1	HW	<b>005066 ●</b>

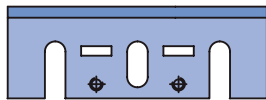

Makita

**Cutting material:**

HS / HW

**Planer knife HS / HW**

TM 105 0

Machine	SB mm	H mm	DIK mm	ID HS	ID HW
Makita	82	29	3	<b>027530 ●</b>	<b>027598 ●</b>

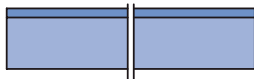

Kity

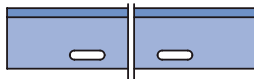

Metabo



Scheppach

**Workpiece material:**

Softwood and hardwood, chipboard and fibre materials, glulam

**Cutting material:**

HS

#### Planer knives for semi-stationary machines

**HS**

TM 100 0, TM 105 0

Machine	SB mm	H mm	DIK mm	QAL	ID
Kity	260	20	2.5	HS	<b>027154 ●</b>
Metabo	263	20	3	HS	<b>027157 ●</b>
Scheppach	260	18	3	HS	<b>027158 ●</b>

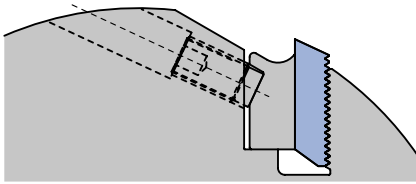

#### Back-serrated profile cutterheads

##### Filler pieces for knife thickness 8 - 10 mm

TD 510 0 05

BEZ	for SB mm	ID
Filler piece	40	005305 ●
Filler piece	60	005306 ●
Filler piece	80	005307 ●
Filler piece	100	005308 ●
Filler piece	120	005309 ●
Filler piece	130	005310 ●
Filler piece	150	005311 ●
Filler piece	170	620770 ●
Filler piece	180	005312 ●
Filler piece	190	620772 ●
Filler piece	210	620773 ●
Filler piece	230	005313 ●
Filler piece	240	620771 ●
Filler piece	270	620774 ●
Filler piece	310	620775 ●

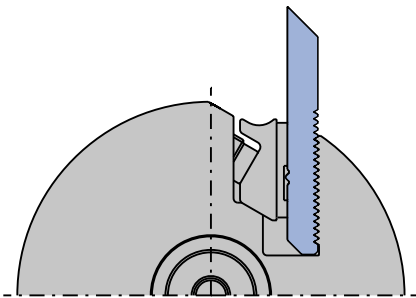

##### Filler pieces for profiling of PKS-system backing plates

TF 200 0

BEZ	for SB mm	ID
Filler piece	40	008355 □
Filler piece	80	008356 □
Filler piece	130	008357 □
Filler piece	170	008358 □
Filler piece	210	008359 □
Filler piece	240	008221 ●

Profile cutterhead  
PKS-system

#### Profile cutterhead WM 502 2

##### Profile cutterhead WM 502 2

TC 105 0

BEZ	SB mm	QAL	ID
Profile blank knife	40	SP	007601 ●
Profile blank knife	50	SP	007602 ●
Profile blank knife	60	SP	007603 ●
Profile blank knife	40	HS	007284 ●
Profile blank knife	50	HS	007285 ●
Profile blank knife	60	HS	007286 ●

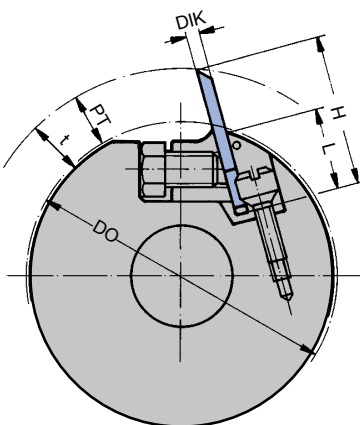

**Workpiece material:**  
Softwood and hardwood

**Cutting material:**  
SP / HS

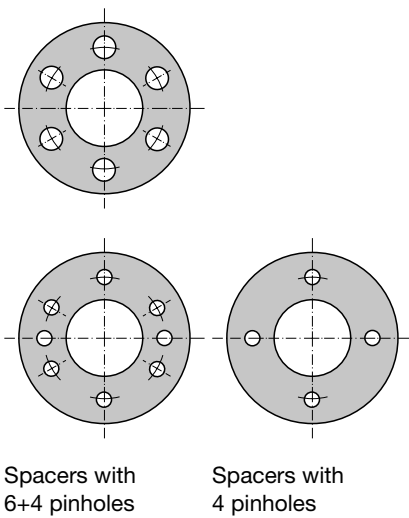

Spacers with 6+4 pinholes

Spacers with 4 pinholes

**With pinholes**

**Spacers with 1 pitch**  
TR 100 0

D mm	B mm	BO mm	NLA mm	ID
45	3	20	4/6/32	028088 ●
45	5	20	4/6/32	028089 ●
45	10	20	4/6/32	028090 ●
45	20	20	4/6/32	028639 ●
45	0.1	20	4/6/32	029208 ●
45	0.3	20	4/6/32	029209 ●
45	0.5	20	4/6/32	029210 ●
45	1	20	4/6/32	029211 ●
60	0.1	30	4/7/48	029237 ●
60	0.1	30	6/7/48	027914 ●
60	0.3	30	4/7/48	029238 ●
60	0.3	30	6/7/48	027915 ●
60	0.5	30	4/7/48	029239 ●
60	0.5	30	6/7/48	027916 ●
60	1	30	4/7/48	029240 ●
60	1	30	6/7/48	027917 ●
60	3	30	6/7/48	028580 ●
60	4	30	6/7/48	028581 ●
60	5	30	6/7/48	028582 ●
60	6	30	6/7/48	028583 ●
60	7	30	6/7/48	028584 ●
60	8	30	6/7/48	028585 ●
60	10	30	6/7/48	028586 ●
60	11	30	6/7/48	028587 ●
60	12	30	6/7/48	028588 ●
60	15	30	6/7/48	028589 ●
60	20	30	6/7/48	028591 ●
70	0.1	30	6/7/58	027952 ●
70	0.3	30	6/7/58	027953 ●
70	0.5	30	6/7/58	027954 ●
70	1	30	6/7/58	027955 ●
70	3	30	6/7/58	028599 ●
70	4	30	6/7/58	028600 ●
70	5	30	6/7/58	028601 ●
70	10	30	6/7/58	028605 ●
70	20	30	6/7/58	028608 ●
60	0.1	35	6/7/48	027930 ●
60	0.3	35	6/7/48	027931 ●
60	0.5	35	6/7/48	027932 ●
60	1	35	6/7/48	027933 ●
60	3	35	6/7/48	028592 ●
60	5	35	6/7/48	028594 ●
60	10	35	6/7/48	028598 ●
62	0.1	35	4/7/52	028667 ●
62	0.3	35	4/7/52	028668 ●
62	0.5	35	4/7/52	028669 ●
62	1	35	4/7/52	028670 ●
64	3	35	4/7/52	028671 ●
64	4	35	4/7/52	028672 ●
64	5	35	4/7/52	028673 ●
70	0.1	35	6/7/58	027966 ●
70	0.3	35	6/7/58	027967 ●
70	0.5	35	6/7/58	027968 ●
70	1	35	6/7/58	027969 ●
70	3	35	6/7/58	028609 ●
70	5	35	6/7/58	028611 ●
70	10	35	6/7/58	028615 ●
70	20	35	6/7/58	028616 ●
70	0.1	40	6/7/58	027978 ●
70	0.3	40	6/7/58	027979 ●
70	0.5	40	6/7/58	027980 ●
70	1	40	6/7/58	027981 ●

D	B	BO	NLA	ID
mm	mm	mm	mm	
70	3	40	6/7/58	028617 ●
70	4	40	6/7/58	028618 ●
70	5	40	6/7/58	028619 ●
70	6	40	6/7/58	028620 ●
70	7	40	6/7/58	028621 ●
70	8	40	6/7/58	028622 ●
70	10	40	6/7/58	028623 ●
70	12	40	6/7/58	028624 ●
70	15	40	6/7/58	028625 ●
70	20	40	6/7/58	028626 ●
76.5	0.1	50	6/7/65	028005 ●
76.5	0.3	50	6/7/65	028006 ●
76.5	0.5	50	6/7/65	028007 ●
76.5	1	50	6/7/65	028008 ●
77	3	50	6/7/65	028627 ●
77	4	50	6/7/65	028628 ●
77	5	50	6/7/65	028629 ●
77	6	50	6/7/65	028630 ●
77	8	50	6/7/65	028631 ●
77	10	50	6/7/65	028632 ●
77	20	50	6/7/65	028633 ●
90	0.1	60	6/9/75	028020 ●
90	0.3	60	6/9/75	028021 ●
90	0.5	60	6/9/75	028022 ●
90	1	60	6/9/75	028023 ●
90	3	60	6/9/75	028634 ●
90	4	60	6/9/75	028635 ●
90	5	60	6/9/75	028636 ●
90	10	60	6/9/75	028637 ●
90	20	60	6/9/75	028638 ●

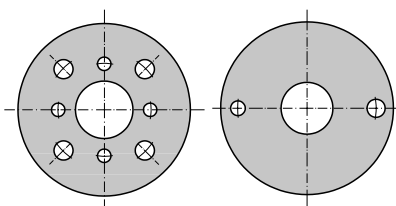
Spacers with  
4+4 pinholesSpacers with  
2 pinholes

### With pinholes

#### Spacers with different pitches

TR 100 0

D	B	BO	NLA	ID
mm	mm	mm	mm	
90	0.1	30	4/7/48	028422 ●
			4/10/60	
90	0.3	30	4/7/48	028423 ●
			4/10/60	
90	0.5	30	4/7/48	028424 ●
			4/10/60	
90	1	30	4/7/48	028425 ●
			4/10/60	
90	3	30	4/7/48	028426 ●
			4/10/60	
90	5	30	4/7/48	028427 ●
			4/10/60	
90	10	30	4/7/48	028428 ●
			4/10/60	
90	20	30	4/7/48	028429 ●
			4/10/60	
100	0.1	30	1/8.5/80	028029 ●
			1/10.5/80	
100	0.3	30	1/8.5/80	028030 ●
			1/10.5/80	
100	0.5	30	1/8.5/80	028031 ●
			1/10.5/80	
100	1	30	1/8.5/80	028032 ●
			1/10.5/80	

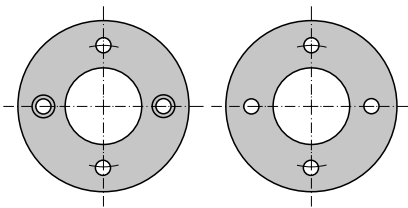

Spacers with 4 pinholes (two of them with cylindrical countersink)

Spacers with 4 pinholes

**With pinholes, aluminium**

**Aluminium spacers**

TR 100 0

D mm	B mm	BO mm	NLA mm	BEM	ID
60	10	30	2/7/48	2 pinholes with cylindrical countersink	<b>029244 ●</b>
64	5	35	4/7/52		<b>029246 ●</b>
64	10	35	4/7/52		<b>029247 ●</b>
64	10	35	2/7/52	Cylindrical countersink pinholes	<b>029248 ●</b>
64	20	35	4/7/52		<b>029249 ●</b>

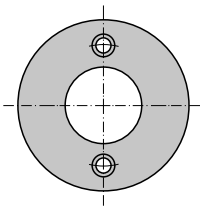

Spacers with 2 pinholes with cylindrical countersink

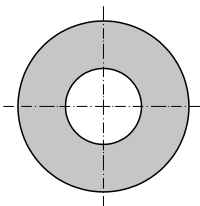

**Without pinholes**

**Without pinholes**

TR 100 0

D mm	B mm	BO mm	ID
34	0.1	20	<b>028400 ●</b>
34	0.3	20	<b>028401 ●</b>
34	0.5	20	<b>028402 ●</b>
34	1	20	<b>028403 ●</b>
34	3	20	<b>028404 ●</b>
34	4	20	<b>028405 ●</b>
34	5	20	<b>028406 ●</b>
50	0.1	30	<b>027901 ●</b>
50	0.3	30	<b>027902 ●</b>
50	0.5	30	<b>027903 ●</b>
50	1	30	<b>027904 ●</b>
50	3	30	<b>027905 ●</b>
50	4	30	<b>027906 ●</b>
50	5	30	<b>027907 ●</b>
50	6	30	<b>027908 ●</b>
50	7	30	<b>027909 ●</b>
50	8	30	<b>027910 ●</b>
50	10	30	<b>027911 ●</b>
50	14	30	<b>027912 ●</b>
50	20	30	<b>027913 ●</b>
60	3	30	<b>027918 ●</b>
60	4	30	<b>027919 ●</b>
60	5	30	<b>027920 ●</b>
60	6	30	<b>027921 ●</b>
60	7	30	<b>027922 ●</b>
60	8	30	<b>027923 ●</b>
60	10	30	<b>027924 ●</b>
60	11	30	<b>027925 ●</b>
60	12	30	<b>027926 ●</b>
60	15	30	<b>027927 ●</b>
60	17.5	30	<b>027928 ●</b>
60	20	30	<b>027929 ●</b>
60	3	35	<b>027934 ●</b>
60	5	35	<b>027936 ●</b>
60	6	35	<b>027937 ●</b>
60	7	35	<b>027938 ●</b>

D	B	BO	ID
mm	mm	mm	
60	8	35	027939 ●
60	10	35	027940 ●
60	0.1	40	027941 ●
60	0.3	40	027942 ●
60	0.5	40	027943 ●
60	1	40	027944 ●
60	3	40	027945 ●
60	4	40	027946 ●
60	5	40	027947 ●
60	6	40	027948 ●
60	7	40	027949 ●
60	8	40	027950 ●
60	9	40	028449 ●
60	10	40	027951 ●
70	3	30	027956 ●
70	4	30	027957 ●
70	5	30	027958 ●
70	6	30	027959 ●
70	7	30	027960 ●
70	8	30	027961 ●
70	10	30	027962 ●
70	12	30	027963 ●
70	15	30	027964 ●
70	20	30	027965 ●
70	3	35	027970 ●
70	4	35	027971 ●
70	5	35	027972 ●
70	6	35	027973 ●
70	7	35	027974 ●
70	8	35	027975 ●
70	10	35	027976 ●
70	20	35	027977 ●
70	3	40	027982 ●
70	4	40	027983 ●
70	5	40	027984 ●
70	6	40	027985 ●
70	7	40	027986 ●
70	8	40	027987 ●
70	10	40	027988 ●
70	12	40	027989 ●
70	15	40	027990 ●
70	20	40	027991 ●
70	0.1	50	027992 ●
70	0.3	50	027993 ●
70	0.5	50	027994 ●
70	1	50	027995 ●
70	3	50	027996 ●
70	4	50	027997 ●
70	5	50	027998 ●
70	6	50	027999 ●
70	7	50	028000 ●
70	8	50	028001 ●
70	10	50	028002 ●
70	15	50	028003 ●
70	20	50	028004 ●
77	3	50	028009 ●
77	4	50	028010 ●
77	5	50	028011 ●
77	6	50	028012 ●
77	8	50	028013 ●
77	10	50	028014 ●
77	20	50	028015 ●
90	3	60	028024 ●
90	4	60	028025 ●
90	5	60	028026 ●
90	10	60	028027 ●
90	20	60	028028 ●
100	4	30	028033 ●



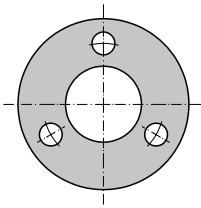

Spacers hardened and high precision for hydro and Hydro-Duo clamping sleeves to fill the clamping length.

### Spacers, hardened and high precision for hydro and Hydro-Duo clamping sleeves

Spacers, hardened and high precision for hydro and Hydro-Duo clamping sleeves

TR 100 0

D	B	BO	NLA	ID
mm	mm	mm	mm	
90	10	60	3/9/75	030684 ●
90	15	60	3/9/75	030685 ●
90	20	60	3/9/75	030686 ●

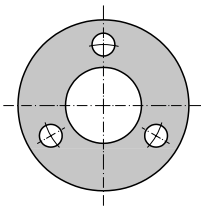

Spacers hardened and high precision for hydro and Hydro-Duo clamping sleeves to fill the clamping length.

### High precision spacers for adjusting tongue and groove cuttersets

High precision spacers for adjusting tongue and groove cuttersets

TR 100 0

D	B	BO	NLA	ID
mm	mm	mm	mm	
90	3.1	60	3/9/75	030687 ●
90	3.3	60	3/9/75	030688 ●
90	3.5	60	3/9/75	030689 ●
90	3.7	60	3/9/75	030690 ●
90	3.9	60	3/9/75	030691 ●
90	4.1	60	3/9/75	030692 ●
90	4.3	60	3/9/75	030693 ●
90	4.5	60	3/9/75	030694 ●
90	4.7	60	3/9/75	030695 ●
90	4.9	60	3/9/75	030696 ●
90	5	60	3/9/75	030697 ●
90	5.1	60	3/9/75	030698 ●

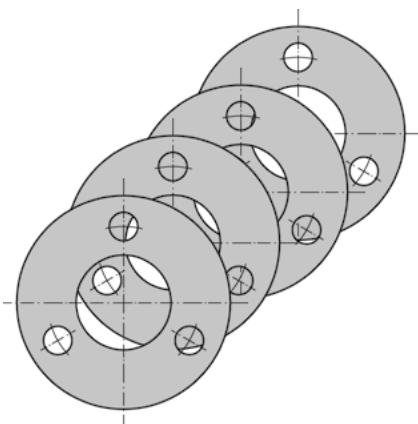

### Spacer sets

Set of standard cutter spindle spacers

AT 100 0 01

D	BO	ID
mm	mm	
50	30	028381 ●
60	40	028382 ●

AT 100 0 01

8 part spacer set with total clamping length 125 mm, surface ground face parallel, spacers black-finished, to DIN 8837

#### Set consisting of:

- 2 pieces: B 5.0 mm
- 2 pieces: B 16.0 mm
- 1 piece: B 8.0 mm
- 1 piece: B 10.0 mm
- 1 piece: B 25.0 mm
- 1 piece: B 40.0 mm



## Ball bearings

### Ball bearings

TL 510 0

BEZ	Type	D mm	D Ring mm	B mm	BO mm	ID
Ball bearing	A	62	min. 85	16	30	<b>008114</b> ●
Ball bearing	A	62	min. 90	16	31.75	<b>008142</b>
Ball bearing	B	80	min. 102	18	40	<b>008116</b> ●
Ball bearing	C	90	min. 112	20	50	<b>008117</b> ●
Ball bearing	D	110	min. 132	22	60	<b>008118</b>

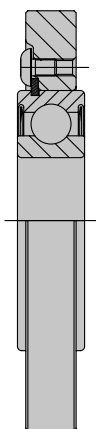

## Guide rings

### Guide rings

TR 500 0

BEZ	Type	D mm	ID
Guide ring	A	85	<b>027826</b> ●
Guide ring	A	90	<b>027799</b> □
Guide ring	A	100	<b>027800</b> ●
Guide ring	A	105	<b>027801</b> □
Guide ring	A	110	<b>027802</b> ●
Guide ring	A	120	<b>027803</b>
Guide ring	A	125	<b>027804</b> ●
Guide ring	A	130	<b>027805</b> ●
Guide ring	A	140	<b>027806</b> ●
Guide ring	A	150	<b>027807</b> ●
Guide ring	B	105	<b>027808</b>
Guide ring	B	110	<b>027809</b>
Guide ring	B	120	<b>027810</b>
Guide ring	B	125	<b>027811</b>
Guide ring	B	130	<b>027812</b>
Guide ring	B	140	<b>027813</b>
Guide ring	B	150	<b>027814</b>
Guide ring	C	112	<b>027815</b>
Guide ring	C	120	<b>027816</b>
Guide ring	C	125	<b>027817</b>
Guide ring	C	130	<b>027818</b>
Guide ring	C	140	<b>027819</b>
Guide ring	C	150	<b>027820</b>
Guide ring	C	160	<b>027821</b>
Guide ring	D	140	<b>027822</b>
Guide ring	D	150	<b>027823</b>
Guide ring	D	160	<b>027824</b>
Guide ring	D	170	<b>027825</b>

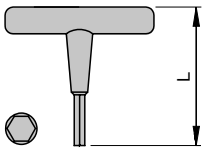

Hexagon key,  
L 75 - 100 mm

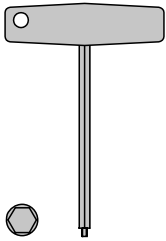

Hexagon key, with  
tenon

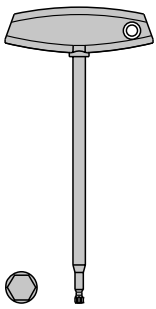

Hexagon key, for  
quick-change  
sleeve

### Hexagon allen keys

#### T-handle without tenon

TH 500 0

ABM mm	L mm	ID
SW 2.5	100	005472 ●
SW 3	75	005444 ●
SW 4	75	005445 ●
SW 6	100	005447 ●

#### T-handle with tenon

TH 500 0

ABM mm	ID
SW 5	005452 ●
SW 6	005494 ●

#### For quick-change chuck

TH 505 0

ABM mm	L mm	ID
SW 6	240	117516 ●

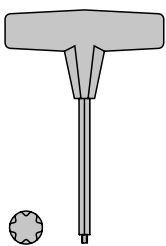

Torx® key with  
T-handle

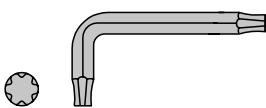

Torx® key, 90° angle

### Torx® keys

#### T-handle

TH 500 0

ABM mm	L mm	ID
Torx® 8		006093 ●
Torx® 9		005463 ●
Torx® 15	100	005466 ●
Torx® 15	130	117507 ●
Torx® 20	100	006091 ●
Torx® 20	130	117503 ●
Torx® 25	100	005502 ●
Torx® 25	130	117504 ●

#### 90° angle

TH 500 0

ABM mm	L mm	ID
Torx® 20	140	117511 ●



## Torque tool set

### TorqueVario®-STplus T-handle torque tool set, 11 parts

AT 199 0

BEZ	BEM	ID
TorqueVario-STplus 5-14 Nm	Bitholder 1/4 inch for bits with drive E 6.3 and C 6.3; Bits of series 7045 Torx and 7043 Hexagon in lengths 70 mm; Torx T 15 - T 20 - T 25; Hexagon SW 4 - SW 5 - SW 6 - SW 8	<b>009103 •</b>

#### Application:

Controlled tightening with predefined torque for changing knife tool systems

#### Design:

Model 5-14 Nm. Numeric torque indicator in the window scale. Steplessly controlled torque by control tool Torque Setter (included in delivery). Comfortable T-handle with soft zones for optimal torque transmission.

#### Precision:

±6%, based on national standards

#### Extra:

Delivery in stable metal box, incl. test protocol

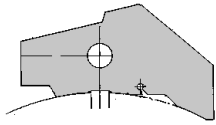

### Setting gauge for hydro planerhead / planerhead wedge-type system

VN 265 0

ABM	ID
mm	
D143	007988 ●
D163	007989 ●
D203	008002 ●

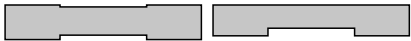
Setting gauge  
0.3/0.8 mm

Setting gauge 1 mm

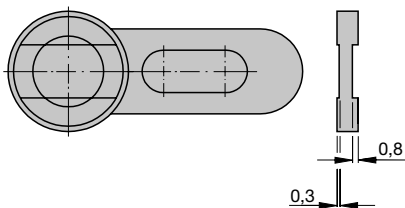

Magnetic setting gauge 0.3/0.8 mm

### Setting gauge for turnblade

VN 230 0

BEZ	ABM	ID
	mm	
Setting gauge for knives	0.3/0.8	005374 ●
Setting gauge for knives	1.0	005350 ●
Magnetic setting gauge	0.3/0.8	005376 ●

### Mounting device

VN 799 0

BEZ	BEM	ID
Mounting device for SK 30/BT30 with grooves and notches	Not for Biesse	079000 ●
Mounting device for SK40		079001 ●
Mounting device for HSK-F50		079002 ●
Mounting device for HSK-E63 and HSK-F63		079044 ●
Mounting device for SCM/Morbidelli ISO30		079004 ●
Mounting device for CMS ISO30		079005 ●
Mounting device for Alberti HSK-E 40		079006 ●



#### Application:

For the assembly of shank tools in clamping chucks or tools with borehole on arbors with adaptors for automatic tool change

- Reduced risk of injury when mounting tools
- Quick clamping levers and fixing pins secure the clamped taper axially as well as against twisting



### Mounting device

**Mounting device for tools with HSK 85 / HSK-F 63 adaptor**  
VN 799 0

BEZ	Machine	l mm	d mm	ID
Mounting device EASY-Hold HSK 85 WS	Weinig	30 - 310	20 - 50	<b>079010 •</b>
Mounting device EASY-Hold HSK-F 63 / HSK-E 63				<b>079009 •</b>

For quick and easy mounting of knives or tools on arbors.

**Application:**

For mounting saws, tools, tool sets and cutterheads



### Mounting device

**Clamping device for drills with 10 mm shank and clamping flat**  
VN 799 0

BEZ	ID
Clamping device for drill 10 mm shank	<b>079020 •</b>

**Application:**

For clamping drills (10 mm shank with clamping flat) when altering the length adjusting screw.

**Advantages:**

- reduced risk of injury when mounting the tools
- easy and stable tool clamping during mounting



### Lifting device for large circular saw blades

#### MagneticGrip Lifting device

VZ 999 0

BEZ	BEM	ID
Lifting device	20 kg load capacity	<b>119900 ●</b>
Lifting device	45 kg load capacity	<b>119901 ●</b>

For optimal lifting, 2 pcs. are recommended.

#### Application:

For easy lifting of large circular saw blades by means of magnetic power

### Jointing stones for Leitz Marathon planer knife

FS 100 0, FS 199 0

BEZ	Machine	BEM	ABM mm	ID
Jointing stone (angular)	WACO	Colour: brown	20x15x60	<b>008238</b> ●
Jointing stone (round)	Weinig, Leadermac	Colour: grey	12x32	<b>008237</b> ●

Grinding wheels suitable for sharpening Marathon planer knives available on request.



## Alphabetical product index

<b>A</b>		Planer knives 30 mm with threaded bore	15
Aluminium spacers	37	Planer knives for portable planers	33
<b>B</b>		Planer knives for semi-stationary machines	33
Ball bearings	40	Planer knives Powerknife System PKS®	17
Ball bearings and guide rings	40	Planer knives with 60° back serration	16
Blank knives	25-29	Profile cutterhead WM 502 2	34
Blank knives / backing plates Powerknife System PKS®	27-29	Profile grooving knives	10
Blank knives with 60° back serration	25-26	Profile knives	30-32
<b>C</b>		Profile knives for multi-purpose cutterheads	30
Changeable knife 8 mm Marathon RipTec for turnblade knife tools Integral	4	<b>R</b>	
Clamping device for drills with 10 mm shank and clamping flat	44	Resharpenable knife for spiral long planerhead	24
<b>E</b>		Rhomboid turnblade knives	11
Edging knives	12-13	<b>S</b>	
<b>F</b>		Set of standard cutter spindle spacers	39
Filler pieces for knife thickness 8 - 10 mm	34	Setting gauge for hydro planerhead / planerhead wedge-type system	43
Filler pieces for profiling of PKS-system backing plates	34	Setting gauge for turnblade	43
<b>G</b>		Setting gauges / mounting devices	43-45
Grooving knives	10	Spacer sets	39
Grooving knives / profile grooving knives	10-11	Spacers	35-39
Guide rings	40	Spacers with 1 pitch	35-36
<b>H</b>		Spacers with different pitches	36
Hexagon allen keys	41	Spacers, hardened and high precision for hydro and Hydro-Duo clamping sleeves	39
High precision spacers for adjusting tongue and groove cuttersets	39	Spare parts and clamping parts	34
HS and MC33 blank knives for cutting to individual cutting width	26	Spiral planer knife	24
HS and MC33 blank knives, for profile and hydro profile cutterheads	25	Spurs	9
<b>J</b>		<b>T</b>	
Jointing stones	46	Torque tool set	42
Jointing stones for Leitz Marathon planer knife	46	TorqueVario®-STplus T-handle torque tool set, 11 parts	42
<b>K</b>		Torx® keys	41
Keys	41-42	Turnblade knife with radius for calibration moulder System Rotoles	8
Knives	30	Turnblade knives	2-8
Knives and blank knives	2-33	Turnblade knives for cutterhead system HeliCut	8
Knives for cassette system	15	Turnblade knives HW	33
<b>L</b>		Turnblade planing knives CASTOR	18
Lamello turnblade knives	11	Turnblade planing knives Centrolock	24
Lifting device for large circular saw blades	45	Turnblade planing knives CentroStar, CentroFix, QuickFix	19-20
Limitors	30	Turnblade planing knives HeliPlan	18
<b>M</b>		Turnblade planing knives MicroTec	23
MagneticGrip Lifting device	45	Turnblade planing knives TriTec	22
Mounting device	43-44	Turnblade planing knives VariPlan / VariPlan Plus	21
Mounting device for tools with HSK 85 / HSK-F 63 adaptor	44	<b>W</b>	
<b>O</b>		WhisperCut DP edges for hybrid tools	32
One-way knife for spiral long planerhead	24	<b>P</b>	
<b>P</b>		Planer knife HS / HW	33
Planer knives	14-24	Planer knives	14-24

ID	Page	ID	Page	ID	Page	ID	Page	ID	Page	ID	Page
005004 ●	5	005308 ●	34	007668 ●	6	008336 ●	12	026315 ●	30	027279 ●	14
005006 ●	5	005309 ●	34	007679 □	2	008337 ●	12	026316 ●	30	027280 ●	14
005050 ●	5	005310 ●	34	007680 □	2	008347 ●	12	026317 ●	30	027281 ●	14
005051 ●	5	005311 ●	34	007681 ●	2	008348 ●	10	026318 ●	30	027282 ●	14
005053 ●	2	005312 ●	34	007682 ●	2	008349 ●	10	026319 ●	30	027283 ●	14
005054 ●	2	005313 ●	34	007988 ●	43	008355 □	34	026320 ●	30	027284 ●	14
005055 ●	2	005350 ●	43	007989 ●	43	008356 □	34	026321 ●	30	027285 ●	14
005056 ●	2	005374 ●	43	008002 ●	43	008357 □	34	026322 ●	30	027286 ●	14
005057 ●	2	005376 ●	43	008114 ●	40	008358 □	34	026331 ●	30	027287 ●	14
005058 ●	2	005400 ●	2	008116 ●	40	008359 □	34	026334 ●	30	027288 ●	14
005059 ●	2	005401 ●	2	008117 ●	40	009103 ●	42	026335 ●	30	027289 ●	14
005064 ●	33	005402 ●	2	008118 ●	40	009527 ●	8	026336 ●	30	027292 ●	14
005066 ●	33	005403 ●	2	008142 ●	40	009535 ●	18	026384 ●	30	027293 ●	14
005068 ●	2	005404 ●	2	008221 ●	34	009540 ●	18	026386 ●	30	027295 ●	14
005069 ●	2	005405 ●	2	008237 ●	46	009543 ●	8	026390 ●	30	027296 ●	14
005070 ●	2	005406 ●	2	008238 ●	46	009549 ●	8	026392 ●	30	027297 ●	14
005071 ●	2	005444 ●	41	008268 ●	12	026101 ●	30	026393 ●	30	027298 ●	14
005072 ●	2	005445 ●	41	008269 ●	12	026103 ●	30	026395 ●	30	027299 ●	14
005073 ●	2	005447 ●	41	008270 ●	12	026105 ●	30	026400 ●	30	027300 ●	14
005074 ●	2	005452 ●	41	008271 ●	12	026108 ●	30	026402 ●	30	027302 ●	14
005075 ●	2	005463 ●	41	008272 ●	12	026109 ●	30	026403 ●	30	027303 ●	14
005076 ●	2	005466 ●	41	008273 ●	12	026110 ●	30	026411 ●	30	027304 □	14
005077 ●	2	005472 ●	41	008274 ●	12	026111 ●	30	026413 ●	30	027305 □	14
005080 ●	6	005494 ●	41	008275 ●	12	026112 ●	30	026420 ●	30	027306 □	14
005081 ●	6	005502 ●	41	008286 ●	12	026113 ●	30	026421 ●	30	027307 □	14
005082 ●	6	006091 ●	41	008287 ●	12	026114 ●	30	027101 ●	14	027308 ●	14
005083 ●	6	006093 ●	41	008290 ●	13	026115 ●	30	027102 ●	14	027309 □	14
005084 ●	6	006506 ●	6	008291 ●	13	026116 ●	30	027103 ●	14	027310 □	14
005085 ●	6	006607 ●	9	008292 ●	13	026117 ●	30	027104 ●	14	027311 □	14
005086 ●	6	006615 ●	9	008293 ●	13	026118 ●	30	027105 ●	14	027312 ●	14
005087 ●	6	006616 ●	9	008294 ●	13	026119 ●	30	027106 ●	14	027313 □	14
005096 ●	7	006825 ●	15	008295 ●	13	026120 ●	30	027107 ●	14	027314 □	14
005097 ●	7	006826 ●	15	008296 ●	13	026121 ●	30	027108 ●	14	027315 ●	14
005098 ●	7	006827 ●	15	008297 ●	13	026122 ●	30	027109 ●	14	027316 ●	14
005099 ●	9	006828 ●	24	008298 ●	13	026131 ●	30	027110 ●	14	027317 ●	14
005100 ●	9	006829 ●	24	008299 ●	13	026134 ●	30	027111 ●	14	027318 □	14
005114 ●	11	006830 ●	24	008305 ●	13	026135 ●	30	027112 ●	14	027319 □	14
005115 ●	9	006831 ●	24	008306 ●	13	026136 ●	30	027113 ●	14	027320 □	14
005116 ●	9	006841 ●	24	008307 ●	12	026177 ●	30	027114 ●	14	027321 ●	14
005120 ●	7	006842 ●	24	008308 ●	12	026179 ●	30	027115 ●	14	027322 ●	14
005121 ●	7	006843 ●	24	008309 ●	13	026183 ●	30	027116 ●	14	027323 ●	14
005122 ●	7	006844 ●	24	008310 ●	13	026185 ●	30	027117 ●	14	027351 ●	14
005130 ●	9	006907 ●	24	008315 ●	10	026186 ●	30	027118 ●	14	027352 ●	14
005131 ●	33	006908 ●	24	008316 ●	10	026188 ●	30	027119 ●	14	027353 ●	14
005158 ●	6	006909 ●	24	008317 ●	10	026193 ●	30	027120 ●	14	027354 ●	14
005159 ●	9	006910 ●	24	008318 ●	10	026195 ●	30	027121 ●	14	027355 ●	14
005161 ●	6	006911 ●	24	008319 ●	10	026196 ●	30	027122 ●	14	027356 ●	14
005184 ●	2	006912 ●	24	008320 ●	10	026254 ●	30	027123 ●	14	027357 ●	14
005185 ●	2	006915 ●	15	008321 ●	10	026256 ●	30	027125 ●	14	027358 ●	14
005186 ●	2	006916 ●	15	008322 ●	10	026263 ●	30	027130 ●	14	027359 ●	14
005187 ●	2	006917 ●	15	008323 ●	10	026264 ●	30	027134 ●	14	027360 ●	14
005188 ●	2	006926 ●	15	008324 ●	10	026301 ●	30	027144 ●	14	027361 ●	14
005189 ●	2	006928 ●	15	008325 ●	10	026303 ●	30	027154 ●	33	027362 ●	14
005190 ●	2	006929 ●	15	008326 ●	10	026305 ●	30	027157 ●	33	027363 ●	14
005191 ●	2	006931 ●	15	008327 ●	10	026308 ●	30	027158 ●	33	027364 ●	14
005195 ●	11	007284 ●	34	008328 ●	10	026309 ●	30	027161 ●	14	027365 ●	14
005197 ●	2	007285 ●	34	008329 ●	11	026310 ●	30	027162 ●	14	027366 ●	14
005198 ●	2	007286 ●	34	008330 ●	11	026311 ●	30	027163 ●	14	027367 ●	14
005305 ●	34	007601 ●	34	008333 ●	10	026312 ●	30	027164 ●	14	027368 ●	14
005306 ●	34	007602 ●	34	008334 ●	12	026313 ●	30	027277 ●	14	027369 ●	14
005307 ●	34	007603 ●	34	008335 ●	12	026314 ●	30	027278 ●	14	027371 ●	14

ID	Page	ID	Page	ID	Page	ID	Page	ID	Page	ID	Page
027387 ●	14	027928 ●	37	027990 ●	38	028580 ●	35	029244 ●	37	601418	3
027388 ●	14	027929 ●	37	027991 ●	38	028581 ●	35	029246 ●	37	601419	3
027389 ●	14	027930 ●	35	027992 ●	38	028582 ●	35	029247 ●	37	601420	3
027390 ●	14	027931 ●	35	027993 ●	38	028583 ●	35	029248 ●	37	601421	3
027530 ●	33	027932 ●	35	027994 ●	38	028584 ●	35	029249 ●	37	601422	3
027598 ●	33	027933 ●	35	027995 ●	38	028585 ●	35	030684 ●	39	601423	3
027799 □	40	027934 ●	37	027996 ●	38	028586 ●	35	030685 ●	39	601424	3
027800 ●	40	027936 ●	37	027997 ●	38	028587 ●	35	030686 ●	39	601425	3
027801 □	40	027937 ●	37	027998 ●	38	028588 ●	35	030687 ●	39	601426	3
027802 ●	40	027938 ●	37	027999 ●	38	028589 ●	35	030688 ●	39	601427	3
027803	40	027939 ●	38	028000 ●	38	028591 ●	35	030689 ●	39	601428	3
027804 ●	40	027940 ●	38	028001 ●	38	028592 ●	35	030690 ●	39	601429	3
027805 ●	40	027941 ●	38	028002 ●	38	028594 ●	35	030691 ●	39	601430	3
027806 ●	40	027942 ●	38	028003 ●	38	028598 ●	35	030692 ●	39	601431	3
027807 ●	40	027943 ●	38	028004 ●	38	028599 ●	35	030693 ●	39	601600 ●	3
027808	40	027944 ●	38	028005 ●	36	028600 ●	35	030694 ●	39	601601 ●	3
027809	40	027945 ●	38	028006 ●	36	028601 ●	35	030695 ●	39	601602 ●	3
027810	40	027946 ●	38	028007 ●	36	028605 ●	35	030696 ●	39	601603 ●	3
027811	40	027947 ●	38	028008 ●	36	028608 ●	35	030697 ●	39	601604 ●	3
027812	40	027948 ●	38	028009 ●	38	028609 ●	35	030698 ●	39	601605 ●	3
027813	40	027949 ●	38	028010 ●	38	028611 ●	35	079000 ●	43	601606 ●	3
027814	40	027950 ●	38	028011 ●	38	028615 ●	35	079001 ●	43	601607 ●	3
027815	40	027951 ●	38	028012 ●	38	028616 ●	35	079002 ●	43	601608 ●	3
027816	40	027952 ●	35	028013 ●	38	028617 ●	36	079004 ●	43	601609 □	3
027817	40	027953 ●	35	028014 ●	38	028618 ●	36	079005 ●	43	601610 ●	3
027818	40	027954 ●	35	028015 ●	38	028619 ●	36	079006 ●	43	601611 ●	3
027819	40	027955 ●	35	028020 ●	36	028620 ●	36	079009 ●	44	601612 □	3
027820	40	027956 ●	38	028021 ●	36	028621 ●	36	079010 ●	44	601613 ●	3
027821	40	027957 ●	38	028022 ●	36	028622 ●	36	079020 ●	44	601614 ●	3
027822	40	027958 ●	38	028023 ●	36	028623 ●	36	079044 ●	43	601615 ●	3
027823	40	027959 ●	38	028024 ●	38	028624 ●	36	091052 ●	32	601616 ●	5
027824	40	027960 ●	38	028025 ●	38	028625 ●	36	091056 ●	32	601617 ●	5
027825	40	027961 ●	38	028026 ●	38	028626 ●	36	091057	32	601618 ●	5
027826 ●	40	027962 ●	38	028027 ●	38	028627 ●	36	091058	32	601619 ●	5
027901 ●	37	027963 ●	38	028028 ●	38	028628 ●	36	091059	32	601620 ●	5
027902 ●	37	027964 ●	38	028029 ●	36	028629 ●	36	091060	32	601621 ●	5
027903 ●	37	027965 ●	38	028030 ●	36	028630 ●	36	091061	32	601628 ●	3
027904 ●	37	027966 ●	35	028031 ●	36	028631 ●	36	091062	32	601629 ●	3
027905 ●	37	027967 ●	35	028032 ●	36	028632 ●	36	091063	32	601630 ●	3
027906 ●	37	027968 ●	35	028033 ●	38	028633 ●	36	091064	32	601631 ●	3
027907 ●	37	027969 ●	35	028088 ●	35	028634 ●	36	117503 ●	41	601632 ●	3
027908 ●	37	027970 ●	38	028089 ●	35	028635 ●	36	117504 ●	41	601633 ●	3
027909 ●	37	027971 ●	38	028090 ●	35	028636 ●	36	117507 ●	41	601634 ●	3
027910 ●	37	027972 ●	38	028381 ●	39	028637 ●	36	117511 ●	41	601635 ●	3
027911 ●	37	027973 ●	38	028382 ●	39	028638 ●	36	117516 ●	41	601636 ●	3
027912 ●	37	027974 ●	38	028400 ●	37	028639 ●	35	119900 ●	45	601637 ●	3
027913 ●	37	027975 ●	38	028401 ●	37	028667 ●	35	119901 ●	45	601638 ●	3
027914 ●	35	027976 ●	38	028402 ●	37	028668 ●	35	601400	3	601639 ●	3
027915 ●	35	027977 ●	38	028403 ●	37	028669 ●	35	601401	3	601640 ●	3
027916 ●	35	027978 ●	35	028404 ●	37	028670 ●	35	601402	3	601641 ●	3
027917 ●	35	027979 ●	35	028405 ●	37	028671 ●	35	601403 ●	3	601642 ●	3
027918 ●	37	027980 ●	35	028406 ●	37	028672 ●	35	601404 ●	3	601643 ●	3
027919 ●	37	027981 ●	35	028422 ●	36	028673 ●	35	601405	3	601644 ●	5
027920 ●	37	027982 ●	38	028423 ●	36	029208 ●	35	601406 ●	3	601645 ●	5
027921 ●	37	027983 ●	38	028424 ●	36	029209 ●	35	601407	3	601646 ●	5
027922 ●	37	027984 ●	38	028425 ●	36	029210 ●	35	601408	3	601647 ●	5
027923 ●	37	027985 ●	38	028426 ●	36	029211 ●	35	601409	3	601648 ●	5
027924 ●	37	027986 ●	38	028427 ●	36	029237 ●	35	601410	3	601649 ●	5
027925 ●	37	027987 ●	38	028428 ●	36	029238 ●	35	601411	3	601704 ●	3
027926 ●	37	027988 ●	38	028429 ●	36	029239 ●	35	601416	3	601705 ●	3
027927 ●	37	027989 ●	38	028449 ●	38	029240 ●	35	601417	3	601706 ●	3

ID	Page	ID	Page	ID	Page	ID	Page	ID	Page	ID	Page
601707 ●	3	602422	6	605118 ●	14	610022 ●	19	610538 ●	21	610938 ●	22
601708 ●	3	602500 ●	9	605119	14	610023 ●	19	610539 □	21	610939 ●	22
601709 ●	3	602515 ●	8	605120	14	610024 ●	19	610541 ●	21	610940 □	22
601710 ●	3	602516 ●	8	605121	14	610025 ●	19	610562 □	21	610941 ●	22
601711 ●	3	602525 ●	8	605122	14	610028 ●	19	610563 □	21	610950 ●	23
601712 ●	3	602526 ●	8	606700 ●	14	610029 ●	19	610564 □	21	610951 □	23
601713 □	3	602527 ●	8	606701 ●	14	610030 ●	19	610569 □	21	610952 □	23
601714 ●	3	602528 ●	8	606702 ●	14	610031 ●	19	610571 □	21	610953 □	23
601715 ●	3	602531 ●	8	606703 ●	14	610032	19	610572 □	21	610954 □	23
601716 □	3	602900 ●	8	606704 ●	14	610034 ●	19	610606 ●	20	610955 □	23
601717 ●	3	602901 ●	18	606705 ●	14	610036 ●	19	610610 ●	20	610956 □	23
601718 ●	3	602904 ●	8	606706 ●	14	610038 ●	19	610612 ●	20	610957 □	23
601719 ●	3	605000	14	606707 ●	14	610040 ●	19	610614 ●	20	610958 □	23
601744	4	605001	14	606708 ●	14	610042 ●	19	610616 ●	20	610959 □	23
601745	4	605002 ●	14	606709 ●	14	610043 ●	19	610620 ●	20	610960 □	23
601746	4	605003	14	606710 ●	14	610203 ●	19	610621 ●	20	610961 □	23
601747	4	605004	14	606711 ●	14	610204 ●	19	610625 ●	20	610962 □	23
601748	4	605005 ●	14	606712 ●	14	610205 ●	19	610627 ●	20	610963 □	23
601749	4	605006 ●	14	606713 ●	14	610206 ●	19	610629 ●	20	610964 □	23
601750	4	605007 ●	14	606714 ●	14	610208 ●	19	610631 ●	20	610965 ●	23
601751	4	605008 ●	14	606715 ●	14	610210 ●	19	610679 ●	20	610966 □	23
601752	4	605009	14	606716 ●	14	610211 ●	19	610680 ●	20	610967 □	23
601753	4	605010	14	606729 ●	14	610212 ●	19	610681	20	610968 □	23
601754	4	605011 ●	14	606730 ●	14	610213 ●	19	610900 □	22	610969 □	23
601755	4	605012 ●	14	606731 ●	14	610214 ●	19	610901 □	22	610970 □	23
601756	4	605013	14	606732 □	14	610215 ●	19	610902 ●	22	610971 □	23
601757	4	605014 ●	14	606733 □	14	610244 ●	19	610903 ●	22	610972 □	23
601758	4	605015	14	606734 □	14	610247 ●	19	610904 ●	22	610973 □	23
601759	4	605016 ●	14	606735 □	14	610278 ●	20	610905 ●	22	610974 □	23
601760	4	605029	14	606736 □	14	610279	20	610906 ●	22	610975 □	23
601761	4	605030	14	606737 □	14	610280 ●	20	610907 ●	22	610976 □	23
601762	4	605031 ●	14	606738 □	14	610281	20	610908 ●	22	610977 □	23
601763	4	605032	14	606739 □	14	610282 ●	20	610909 ●	22	610978 □	23
601764	4	605033	14	606740 □	14	610283 ●	20	610910 ●	22	610979 □	23
601765	4	605034 ●	14	606745 ●	14	610284 ●	20	610911 ●	22	610980 □	23
601766	4	605035	14	606746 ●	14	610285	20	610912 ●	22	610981 □	23
601767	4	605036 ●	14	606800 ●	14	610286 ●	19	610913 ●	22	610982 □	23
601768	4	605037	14	606801 ●	14	610287 ●	19	610914 ●	22	610983 □	23
601769	4	605038 ●	14	606802 ●	14	610288	19	610915 ●	22	611204 □	21
601770	4	605039	14	606803 ●	14	610500 □	21	610916 ●	22	611205 □	21
601771	4	605040 ●	14	606804 ●	14	610501 □	21	610917 ●	22	611206 ●	21
601772	4	605045 ●	14	606805 ●	14	610502 □	21	610918 ●	22	611209 ●	21
601773	4	605046	14	606806 □	14	610504 ●	21	610919 ●	22	611211 ●	21
601774	4	605100	14	606807 □	14	610505 ●	21	610920 ●	22	611212 ●	21
601775	4	605101	14	606808 □	14	610506 ●	21	610921 ●	22	611214 ●	21
602001 ●	6	605102	14	606809 □	14	610509 ●	21	610922 ●	22	611215 ●	21
602002 ●	6	605103	14	606810 □	14	610511 ●	21	610923 □	22	611216 ●	21
602003 ●	6	605104	14	606811 □	14	610512 ●	21	610924 ●	22	611218 ●	21
602004 ●	6	605105 ●	14	606812 □	14	610514 ●	21	610925 ●	22	611222 ●	21
602005 ●	6	605106	14	606813 □	14	610515 ●	21	610926 □	22	611265 ●	21
602006 ●	6	605107	14	606814 □	14	610516 ●	21	610927 ●	22	611269 ●	21
602009 ●	7	605108 ●	14	606815 □	14	610518 ●	21	610928 □	22	611271 ●	21
602010 ●	7	605109 ●	14	606816 □	14	610522 ●	21	610929 □	22	611801 ●	24
602414	6	605110	14	606817 □	14	610526 □	21	610930 ●	22	611802 ●	24
602415	6	605111 ●	14	606818 □	14	610527 ●	21	610931 ●	22	611803 ●	24
602416 ●	6	605112	14	606819 ●	14	610528 □	21	610932 ●	22	611804 ●	24
602417	6	605113	14	606820 ●	14	610529 □	21	610933 ●	22	611805 ●	24
602418	6	605114 ●	14	606821 ●	14	610530 □	21	610934 □	22	611806 ●	24
602419 ●	6	605115	14	606822 ●	14	610533 ●	21	610935 ●	22	611807 ●	24
602420	6	605116	14	610017 ●	19	610536 □	21	610936 ●	22	611808 ●	24
602421 ●	6	605117	14	610018 ●	19	610537 □	21	610937 ●	22	611809 ●	24

ID	Page	ID	Page	ID	Page	ID	Page	ID	Page	ID	Page
611810 ●	24	617102 □	21	696604 □	17	696665 □	28	697334 ●	25	697531 □	25
611811 ●	24	617104 □	21	696605 ●	17	696666 □	28	697335 ●	25	697532 □	25
611812 ●	24	617105 □	21	696606 ●	17	696667 ●	28	697336 □	25	697533 □	25
611813 ●	24	617106 ●	21	696607 □	17	696670 ●	28	697337 □	25	697534 □	25
611814 ●	24	617109 ●	21	696608 □	17	696671 ●	28	697338 □	25	697535 □	25
611817 ●	24	617111 ●	21	696609 ●	17	696672 ●	28	697339 ●	25	697536 □	25
611831 ●	24	617112 ●	21	696610 □	17	696673 ●	28	697340 ●	25	697537 □	25
611832 ●	24	617114 ●	21	696611 ●	17	696674 ●	28	697341 □	25	697538 □	25
611833 ●	24	617115 ●	21	696612 □	17	696675 ●	28	697342 □	25	697539 □	25
611834 ●	24	617116 ●	21	696613 ●	17	696676 □	28	697343 ●	25	697540 □	25
611835 ●	24	617118 ●	21	696614 □	17	696677 □	28	697344 ●	25	697541 □	25
611836 ●	24	617122 ●	21	696615 □	17	696678 □	28	697345 ●	25	697542 □	25
611837 ●	24	617124 □	21	696616 □	17	696679 □	28	697346 ●	25	697543 □	25
611838 ●	24	617125 □	21	696617 □	17	696680 □	28	697347 ●	25	697544 □	25
611839 ●	24	617126 □	21	696618 □	17	696681 ●	28	697348 ●	25	697800 □	17
611840 ●	24	617127 □	21	696619 ●	17	696684 ●	29	697349 ●	25	697801 □	17
611841 ●	24	617129 □	21	696620 ●	17	696685 ●	29	697350 ●	25	697802 □	17
611842 ●	24	617130 □	21	696621 □	17	696686 ●	29	697351 ●	25	697803 □	17
611843 ●	24	617133 □	21	696622 □	17	696687 ●	29	697352 □	25	697804 □	17
611847 ●	24	617136 □	21	696623 ●	17	696688 ●	29	697353 □	25	697805 ●	17
611861 ●	24	617137 □	21	696624 □	17	696689 ●	29	697354 □	25	697806 ●	17
611862 ●	24	617138 □	21	696625 ●	17	696691 ●	29	697355 ●	25	697807 □	17
611863 ●	24	617139 □	21	696626 □	17	696692 ●	29	697356 □	25	697808 □	17
611864 ●	24	617141 □	21	696627 ●	17	696693 ●	29	697357 □	25	697809 ●	17
611865 ●	24	617162 □	21	696628 ●	27	696694 ●	29	697358 □	25	697810 □	17
611866 ●	24	617163 □	21	696629 ●	27	696695 ●	29	697359 □	16	697811 ●	17
611867 ●	24	617164 □	21	696630 ●	27	696696 ●	29	697360 □	16	697812 □	17
611868 ●	24	617165 ●	21	696631 ●	27	697300 ●	16	697361 □	16	697813 ●	17
611869 ●	24	617169 ●	21	696632 ●	27	697301 ●	16	697362 □	16	697814 □	17
611870 ●	24	617171 ●	21	696633 ●	27	697302 ●	16	697363 □	16	697815 □	17
611871 ●	24	617172 ●	21	696634 □	27	697303 ●	16	697500 □	25	697816 □	17
611872 ●	24	620770 ●	34	696635 □	27	697304 ●	16	697501 □	25	697817 □	17
611873 ●	24	620771 ●	34	696636 □	27	697305 ●	16	697502 □	25	697818 □	17
611877 ●	24	620772 ●	34	696637 □	27	697306 ●	16	697503 □	25	697819 ●	17
611904	21	620773 ●	34	696638 □	27	697307 ●	16	697504 □	25	697820 ●	17
611905	21	620774 ●	34	696639 ●	27	697308 ●	16	697505 □	25	697821 □	17
611906 ●	21	620775 ●	34	696640 □	27	697309 ●	16	697506 □	25	697822 □	17
611909	21	635000 ●	26	696641 ●	27	697310 ●	16	697507 □	25	697823 ●	17
611911 ●	21	635001 ●	26	696642 ●	27	697311 ●	16	697508 □	25	697824 □	17
611912 ●	21	635002 ●	26	696643 ●	27	697312 ●	16	697509 □	25	697825 ●	17
611914	21	635003 □	26	696644 ●	27	697313 ●	16	697510 □	25	697826 □	17
611915	21	635004 □	26	696645 ●	27	697314 ●	25	697511 □	25	697827 ●	17
611916	21	635203 □	26	696646 ●	27	697315 ●	25	697512 □	25	697828 ●	27
611918 ●	21	635204 □	26	696647 ●	27	697316 ●	25	697513 □	25	697829 ●	27
611922	21	635205 □	26	696648 □	27	697317 ●	25	697514 □	25	697830 ●	27
611965	21	635206 □	26	696649 □	27	697318 ●	25	697515 □	25	697831 ●	27
612016 ●	20	635207 □	26	696650 □	27	697319 ●	25	697516 □	25	697832 ●	27
612017 ●	20	690000 ●	30	696651 □	27	697320 ●	25	697517 □	25	697833 ●	27
612018 ●	20	690001 ●	30	696652 □	27	697321 □	25	697518 □	25	697834 □	27
612019 ●	20	690003 ●	30	696653 ●	27	697322 □	25	697519 □	25	697835 □	27
612022 ●	20	690005 ●	30	696654 □	27	697323 □	25	697520 □	25	697836 □	27
612023 ●	20	690007 ●	30	696655 ●	27	697324 ●	25	697521 □	25	697837 □	27
612024 ●	20	695000 ●	30	696656 ●	28	697325 ●	25	697522 □	25	697838 □	27
612025 ●	20	695001 ●	30	696657 ●	28	697326 □	25	697523 □	25	697839 ●	27
612026 ●	20	695003 ●	30	696658 ●	28	697327 □	25	697524 □	25	697840 □	27
616000 ●	10	695005 ●	30	696659 ●	28	697328 ●	25	697525 □	25	697841 ●	27
616001 ●	10	695007 ●	30	696660 ●	28	697329 ●	25	697526 □	25	697842 ●	27
616002 ●	10	696600 □	17	696661 ●	28	697330 ●	25	697527 □	25	697843 ●	27
616003 ●	10	696601 □	17	696662 □	28	697331 ●	25	697528 □	25	697844 ●	27
617100 □	21	696602 □	17	696663 □	28	697332 ●	25	697529 □	25	697845 ●	27
617101 □	21	696603 □	17	696664 □	28	697333 ●	25	697530 □	25	697846 ●	27

ID	Page
697847 ●	27
697848 □	27
697849 □	27
697850 □	27
697851 □	27
697852 □	27
697853 ●	27
697854 □	27
697855 ●	27
697856 ●	28
697857 ●	28
697858 ●	28
697859 ●	28
697860 ●	28
697861 ●	28
697862 □	28
697863 □	28
697864 □	28
697865 □	28
697866 □	28
697867 ●	28
697870 ●	28
697871 ●	28
697872 ●	28
697873 ●	28
697874 ●	28
697875 ●	28
697876 □	28
697877 □	28
697878 □	28
697879 □	28
697880 □	28
697881 ●	28
697884 ●	29
697885 ●	29
697886 ●	29
697887 ●	29
697888 ●	29
697889 ●	29
697891 ●	29
697892 ●	29
697893 ●	29
697894 ●	29
697895 ●	29
697896 ●	29

# Key to pictograms

