

1) Razlika između EN standarda 310 i 789.

EN 310 STANDARD – ispitivanje strukturnih ploča

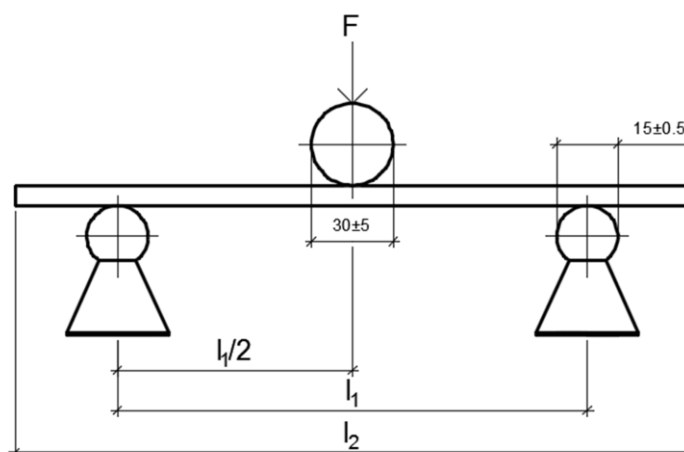

1-eproveta za ispitivanje

B=50mm

F-silapritiska $l_{2min}=150mm$

t-debljina epruvete

$l_{2max}=1050mm$

$l_1=20t$ (mm)

$l_2= l_1+50$ (mm)

$$f_s = \frac{3F_{max} * l_1}{2 * b * t^2} (MPa) E_m = \frac{M^3 * (F_2 - F_1)}{4 * b * t^3 * (a_1 - a_2)} (Mpa)$$

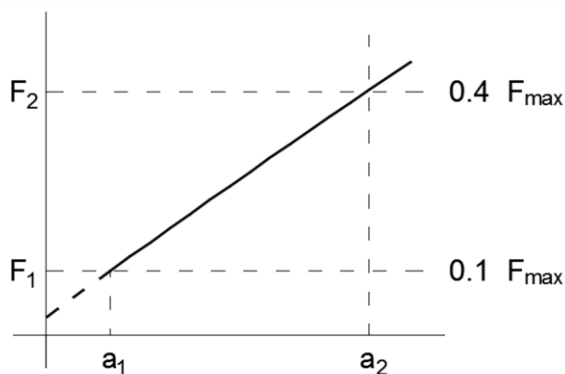

EN 789 STANDARD – ispitivanje strukturalnih ploča

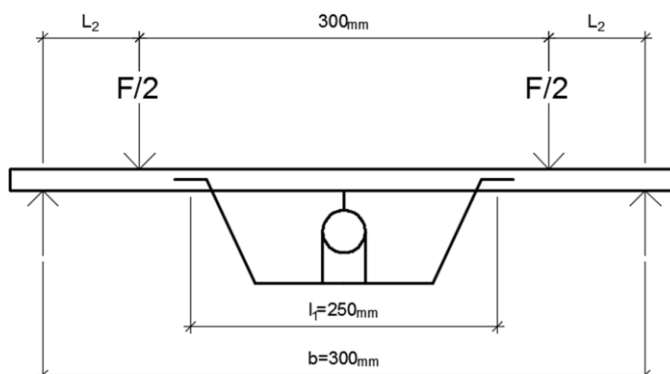

$L_2 = 16t$
 min 240, max 400
 $L_1 = 250$
 $b = 300 \text{ mm}$

$$f_s = \frac{F_{max} * l_2}{2 * \frac{b * t^2}{6}} \text{ (Mpa)} \quad E_m = \frac{l_1^2 * l_2 * (F_2 - F_1)}{16 * \frac{b * t^3}{12} * (a_2 - a_1)} \text{ (MPa)}$$

REDNI BROJ SA SPISKA 1

d (mm)	Fmax	F ₂	F ₁	a ₁	a ₂
22	760N	40%	10%	30	25

B – PRORAČUN

- 1) Izračunati dimenzije uzoraka za ispitivanje savojne čvrstoće po EN 310 i EN 789 standarda, ako se ispituju ploče sledećih debljina: 4mm, 20mm i 60mm
- 2) Za izabranu vrednost debljine ploče, silu lomaiugi bauzorka, izračunati savojnu čvrstoću i modul elastičnosti pri savijanju. Proračun uraditi za EN 310 i EN 789, a kod EN 789 uzeti da je sila loma (Fmax) 10 puta veća od zadate u tabeli.

EN 310

1) $t = 4\text{mm}$

$$l_1 = 20 \cdot t = 20 \cdot 4 = 80\text{mm}$$

$$l_2 = l_1 + 50 = 80 + 50 = 130\text{mm} \Rightarrow 150\text{mm}$$

2)

$$t = 20\text{mm}$$

$$l_1 = 20 \cdot t = 20 \cdot 20 = 400\text{mm}$$

$$l_2 = l_1 + 50 = 400 + 50 = 450\text{mm}$$

3) $t = 60\text{mm}$

$$l_1 = 20 \cdot t = 20 \cdot 60 = 1200\text{mm}$$

$$l_2 = l_1 + 50 = 1200 + 50 = 1250\text{mm} \Rightarrow 1050\text{mm}$$

EN 789

1) $t = 4\text{mm}$

$$l_1 = 250\text{mm}$$

$$l_2 = 16 \cdot t = 16 \cdot 4 = 64\text{mm} \Rightarrow 240\text{mm}$$

$$Luk = 2 \cdot l_2 + 300 + 50 = 830\text{mm}$$

2) $t = 20\text{mm}$

$$l_1 = 250\text{mm}$$

$$l_2 = 16 \cdot t = 16 \cdot 20 = 320\text{mm}$$

$$Luk = 2 \cdot l_2 + 300 + 50 = 990\text{mm}$$

3) $t = 60\text{mm}$

$$l_1 = 250\text{mm}$$

$$l_2 = 16 \cdot t = 16 \cdot 60 = 960\text{mm} \Rightarrow 400\text{mm}$$

$$Luk = 2 \cdot l_2 + 300 + 50 = 1150\text{mm}$$

EN 310

1) $t = 22\text{mm}$

$F_{\max} = 760\text{N}$

$l_1 = 20 \cdot t = 20 \cdot 22 = 440\text{mm}$

$$f_s = \frac{3F_{\max} \cdot l_1}{2 \cdot b \cdot t^2} = \frac{3 \cdot 760 \cdot 440}{2 \cdot 50 \cdot 22^2} = 20.72 \text{ Mpa}$$

$$F_2 = 0,4 \cdot F_{\max} = 304\text{N}$$

$$F_1 = 0,1 \cdot F_{\max} = 76 \text{ N}$$

$$E_m = \frac{l_1^3 \cdot (F_2 - F_1)}{4 \cdot b \cdot t^3 \cdot (a_1 - a_2)} = \frac{440^3 \cdot (304 - 76)}{4 \cdot 50 \cdot 22^3 \cdot (30 - 25)} = 1824 \text{ N/mm}^2$$

EN 789

2) $t = 22\text{mm}$

$F_{\max} = 7600\text{N}$

$l_1 = 250\text{mm}$

$l_2 = 16 \cdot t = 16 \cdot 22 = 352\text{mm}$

$b = 300\text{mm}$

$$f_s = \frac{F_{\max} \cdot l_2}{2 \cdot b \cdot t^2} = \frac{7600 \cdot 352}{2 \cdot \frac{300 \cdot 22^2}{6}} = 55.27 \text{ Mpa}$$

$$F_2 = 0,4 \cdot F_{\max} = 3040\text{N}$$

$$F_1 = 0,1 \cdot F_{\max} = 760 \text{ N}$$

$$E_m = \frac{l_1^2 \cdot l_2 \cdot (F_2 - F_1)}{16 \cdot \frac{b \cdot t^3}{12} \cdot (a_2 - a_1)} = \frac{250^2 \cdot 352 \cdot (3040 - 760)}{16 \cdot \frac{300 \cdot 22^3}{12} \cdot (30 - 25)} = 2355.17 \text{ N/mm}^2$$

Datum	Radio	Datum	Overio
	Poledica Nemanja 42-17		